

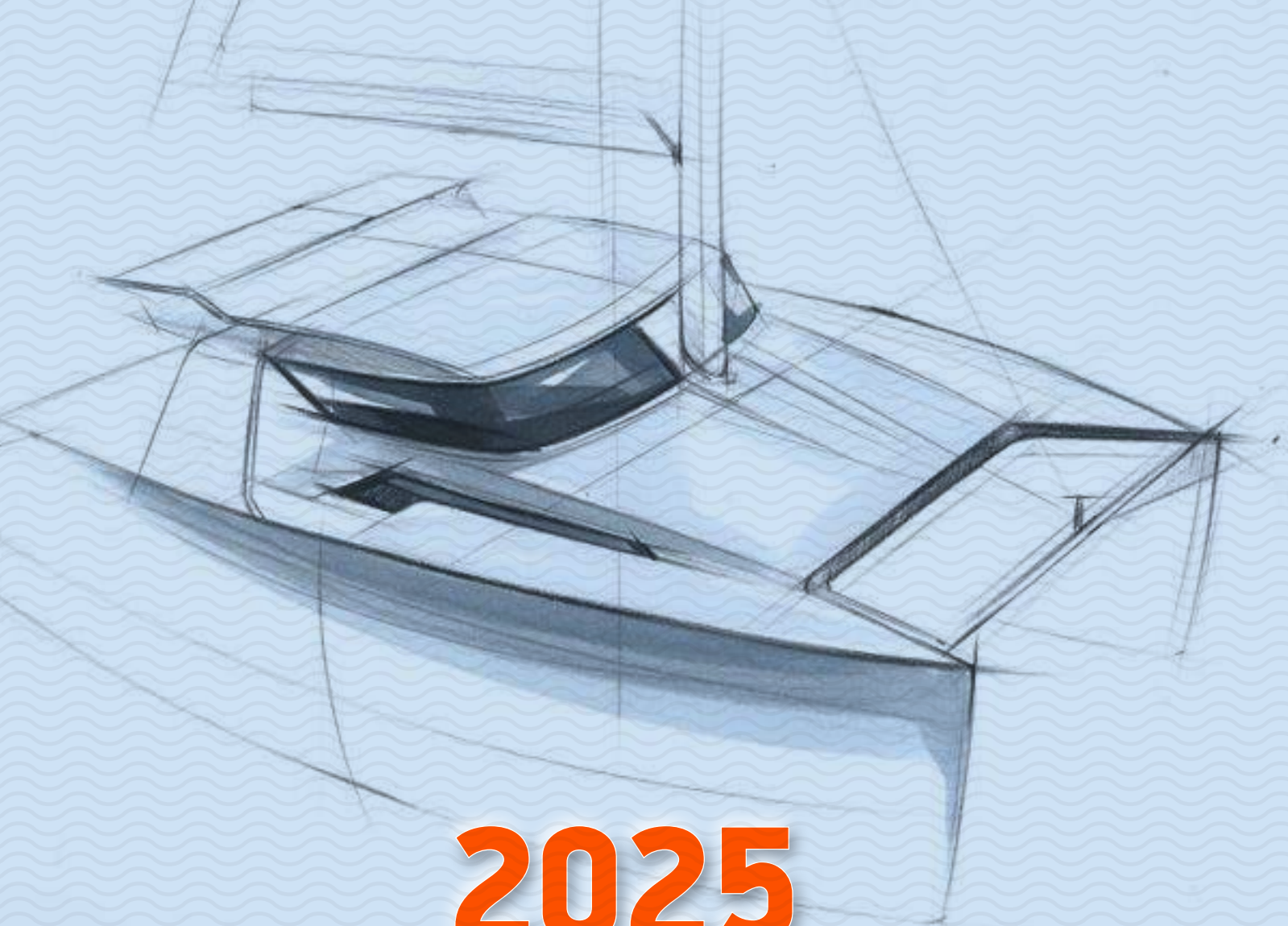

***Sail
marine***



2025

ΚΑΤΑΛΟΓΟΣ
ΝΑΥΤΙΛΙΑΚΩΝ
ΕΙΔΩΝ



Αγαπητοί συνεργάτες,

Η εταιρεία **Sail Marine** μέσα από τα 34 χρόνια της παρουσία της στο χώρο των ναυτιλιακών και σωστικών ειδών, επιδιώκει και ανταποκρίνεται καθημερινά στις απαιτήσεις των συνεργατών της και καλύπτει τις ανάγκες τους που αφορούν τον εξοπλισμό σκαφών.

Στην τελευταία έκδοση του παρόντος καταλόγου, εντάσσεται μια ευρεία ποικιλία προϊόντων από σημαντικούς και διακεκριμένους οίκους στο χώρο της ναυτιλίας.

Για την καλύτερη εξυπηρέτησή σας, επισκευθείτε μας στις εγκαταστάσεις μας ή στην συνεχώς ανανεούμενη ιστοσελίδα μας:

www.sailmarine.gr

Φιλικά

Δημήτρης Νικολαΐδης
Άνθιμος & Γεράσιμος Νικολαΐδης

ΑΓΚΥΡΟΒΟΛΙΑ-ΠΡΟΣΔΕΣΗ

ΑΓΚΥΡΕΣ	4-6
ΑΛΥΣΙΔΕΣ	6
ΚΛΕΙΔΙΑ-ΑΓΚΙΣΤΡΑ	7
ΣΤΡΙΦΤΑΡΙΑ-ΡΟΔΑΤΖΕΣ	8
ΡΑΟΥΛΑ ΠΛΩΡΗΣ	9
ΕΛΑΤΗΡΙΑ	10
ΕΡΓΑΤΕΣ ΑΓΚΥΡΑΣ	11-12
ΒΩΤΗΡUSTERS-ΗΛΕΚΤΡΙΚΗ ΑΓΚΥΡΑ	13-14
ΣΧΟΙΝΙΑ	15-18
ΑΞΕΣΟΥΑΡ ΣΧΟΙΝΙΩΝ	19
ΡΑΟΥΛΑ ΙΣΤΙΟΠΛΟΪΑΣ	20-21
ΜΠΑΛΟΝΙΑ	22-25
ΣΗΜΑΔΟΥΡΕΣ	26-27

ΕΞΟΠΛΙΣΜΟΣ ΚΙΝΗΤΗΡΩΝ

ΚΟΝΕΚΤΟΡΕΣ	28
ΠΟΥΑΡ-ΣΩΛΗΝΕΣ ΚΑΥΣΙΜΟΥ	29
ΛΑΔΙΑ	30
ΚΑΝΙΣΤΡΑ	31
ΡΕΖΕΡΒΟΥΑΡ ΚΑΥΣΙΜΟΥ	32-35
ΑΞΕΣΟΥΑΡ ΡΕΖΕΡΒΟΥΑΡ-ΜΕΤΡΗΤΕΣ	36-37
ΕΞΑΕΡΙΣΤΙΚΑ ΚΑΥΣΙΜΟΥ	37
ΤΑΠΕΣ ΠΛΗΡΩΣΗΣ-ΕΞΑΕΡΙΣΤΙΚΑ ΚΑΥΣΙΜΟΥ	38
ΣΙΓΑΣΤΗΡΕΣ (ΣΙΛΑΝΣΙΕ)	39
ΥΔΑΤΟΠΑΓΙΔΑ-ΦΙΛΤΡΑ	40-41

ΥΔΡΑΥΛΙΚΟΣ ΕΞΟΠΛΙΣΜΟΣ

ΑΝΤΛΙΕΣ ΣΕΝΤΙΝΑΣ	42-45
ΦΛΟΤΕΡ ΣΕΝΤΙΝΑΣ-ΑΝΤΛΙΕΣ ΧΕΙΡΟΚΙΝΗΤΕΣ	46
ΠΡΕΣΟΣΤΑΤΙΚΕΣ ΑΝΤΛΙΕΣ	47-51
ΑΝΤΛΙΕΣ-ΑΝΤΑΛΛΑΚΤΙΚΑ	52
ΝΤΟΥΣ ΝΕΡΟ - ΕΞΑΡΤΗΜΑΤΑ	53-54
ΔΕΞΑΜΕΝΕΣ ΝΕΡΟΥ	55-56
ΕΞΑΡΤΗΜΑΤΑ ΣΩΛΗΝΩΣΕΩΝ	57-59
ΣΩΛΗΝΕΣ ΚΑΥΣΙΜΟΥ-ΝΕΡΟΥ-ΑΚΑΘΑΡΤΩΝ	60
ΒΑΛΒΙΔΕΣ ΝΕΡΟΥ-ΒΑΝΕΣ	61-62

ΥΔΡΟΡΡΟΕΣ-ΤΑΠΕΣ ΚΑΤΑΣΤΡΩΜΑΤΟΣ	63-65
ΑΝΤΛΙΕΣ ΛΥΜΑΤΩΝ	65
ΝΤΕΠΟΖΙΤΑ-ΑΞΕΣΟΥΑΡ ΑΚΑΘΑΡΤΩΝ	66-67
ΤΟΥΑΛΕΤΑ	68-73

ΗΛΕΚΤΡΟΛΟΓΙΚΟΣ ΕΞΟΠΛΙΣΜΟΣ

ΡΑΔΙΟ ΜΡ3-ΗΧΕΙΑ-VHF	74-76
ΚΕΡΑΙΕΣ	77
ΚΟΡΝΕΣ	78
ΑΕΡΑΓΩΓΟΙ - ΑΝΕΜΙΣΤΗΡΕΣ	79-80
ΔΙΑΚΟΠΤΕΣ & ΑΞΕΣΟΥΑΡ ΜΠΑΤΑΡΙΑΣ	80-84
ΚΑΛΩΔΙΑ	85-89
ΟΡΓΑΝΑ	90-91
ΑΣΦΑΛΕΙΕΣ-ΑΣΦΑΛΕΙΟΘΗΚΕΣ	92
ΠΙΝΑΚΕΣ - ΠΡΙΖΕΣ	93-98
ΠΛΑΦΟΝΙΕΡΕΣ-ΛΑΜΠΑΚΙΑ	99-101
ΠΡΟΒΟΛΕΙΣ	102-103
ΥΠΟΒΡΥΧΙΟΣ ΦΩΤΙΣΜΟΣ	103-104
ΦΑΝΟΙ ΝΑΥΣΙΠΛΟΪΑΣ-ΙΣΤΟΙ	105-111

ΠΛΟΗΓΗΣΗ

ΥΑΛΟΚΑΘΑΡΙΣΤΗΡΕΣ	111
ΠΥΞΙΔΕΣ	112
ΤΙΜΟΝΙΑ-ΑΞΕΣΟΥΑΡ ΤΙΜΟΝΙΟΥ	113-115
ΧΕΙΡΙΣΤΗΡΙΑ	115
ΦΛΑΠΣ	116
ΥΔΡΑΥΛΙΚΑ ΤΙΜΟΝΙΑ	117-119
ΝΤΙΖΟΦΟΥΣΚΕΣ-ΝΤΙΖΕΣ	120-123

ΜΟΝΙΜΟΣ ΕΞΟΠΛΙΣΜΟΣ

ΑΜΟΡΤΙΣΕΡ-ΕΛΑΤΗΡΙΑ	124
ΕΣΤΙΕΣ-ΚΟΥΖΙΝΕΣ	125-128
ΘΕΡΜΟΣΙΦΩΝΕΣ	127
ΝΕΡΟΧΥΤΕΣ	129
ΨΥΓΕΙΑ IGLOO	130-132
ΒΑΣΕΙΣ ΜΗΧΑΝΗΣ	133
ΚΟΤΣΑΝΕΛΑ-ΧΕΙΡΟΛΑΒΕΣ-ΙΝΟΧ-	

ΜΕΝΤΕΣΕΔΕΣ-ΠΟΡΤΑΚΙΑ -HATCH	134-145
ΣΚΑΛΕΣ	146-147
ΠΑΣΑΡΕΛΕΣ	148
ΤΕΝΤΕΣ-ΡΟΛ ΜΠΑΡ Τ-ΤΟΡ	149-151
ΚΑΘΙΣΜΑΤΑ	152-153
ΤΡΑΠΕΖΙΑ	154
ΚΑΛΑΜΟΘΗΚΕΣ	155

ΑΞΕΣΟΥΑΡ ΣΚΑΦΟΥΣ

ΘΗΚΕΣ ΓΙΑ ΑΞΕΣΟΥΑΡ-ΠΟΤΗΡΟΘΗΚΕΣ	156
ΚΑΛΥΜΑΤΑ ΣΚΑΦΟΥΣ-ΜΗΧΑΝΗΣ	157-159
ΓΑΝΤΖΟΙ-ΚΟΥΠΙΑ	160-161
ΑΞΕΣΟΥΑΡ ΠΛΥΣΙΜΑΤΟΣ	162-169
ΥΦΑΛΟΧΡΩΜΑΤΑ-ΣΙΛΙΚΟΝΕΣ	170-171

ΣΩΣΤΙΚΟΣ ΕΞΟΠΛΙΣΜΟΣ ΕΞΟΠΛΙΣΜΟΣ ΚΑΤΑΣΤΡΩΜΑΤΟΣ

ΣΩΣΙΒΙΑ	172-174
ΚΥΚΛΙΚΑ ΣΩΣΙΒΙΑ-ΣΥΣΤΗΜΑΤΑ ΔΙΑΣΩΣΗΣ	175-176
ΣΗΜΑΤΑ ΔΙΑΣΩΣΗΣ-ΣΩΣΤΙΚΟΙ ΦΑΝΟΙ	177
ΣΩΣΙΒΙΕΣ ΣΧΕΔΙΕΣ LIFERAFT	178
ΣΩΣΤΙΚΑ ΑΞΕΣΟΥΑΡ-ΕΡΓΑΛΕΙΟΘΗΚΕΣ-ΣΟΥΓΙΑΔΕΣ	179-181
ΧΑΡΤΕΣ-ΒΙΒΛΙΑ	182
ΠΥΡΟΣΒΕΣΤΗΡΕΣ	183
ΣΗΜΑΙΕΣ-ΠΛΩΤΕΣ ΑΓΚΥΡΕΣ	183
ΦΑΡΜΑΚΕΙΑ	184
ΕΞΟΠΛΙΣΜΟΣ ΚΑΤΑΣΤΡΩΜΑΤΟΣ	185

ΕΞΟΠΛΙΣΜΟΣ ΤΡΕΪΛΕΡ

ΙΜΑΝΤΕΣ ΠΡΟΣΔΕΣΗΣ	186
ΒΙΝΤΖΑΚΙΑ	187
ΦΑΝΑΡΙΕΡΕΣ	187
ΡΟΔΑΚΙΑ ΤΡΕΪΛΕΡ	188

ΦΟΥΣΚΩΤΑ

ΤΡΟΜΠΕΣ	189-190
ΑΞΕΣΟΥΑΡ ΦΟΥΣΚΩΤΩΝ	191

ΦΟΥΣΚΩΤΑ	192-193
ΕΞΩΛΕΜΒΙΕΣ ΜΗΧΑΝΕΣ	194-195
SUP-ΚΑΓΙΑΚ	196-199

ΕΝΔΥΣΗ

ΝΙΤΣΕΡΑΔΕΣ	200
ΜΠΟΥΦΑΝ ΙΣΤΙΟΠΛΟΙΑΣ-ΠΑΠΟΥΤΣΙΑ	201-202
ΘΑΛΑΣΣΙΑ ΣΠΟΡ	203-204

ΕΙΔΗ ΔΩΡΩΝ

205

ΑΝΟΔΙΑ

ΑΞΟΝΑΣ-ΦΛΑΠΣ	206
BOMBARDIER	207
HONDA	208
MERCURY-MERCUISER	209-210
SELVA	210
VOLVO PENTA	211
SUZUKI-TOHATSU-YANMAR	212
YAMAHA	213
ΑΝΟΔΙΑ ΜΕ ΣΠΕΙΡΩΜΑ	214
KIT ΑΝΟΔΙΩΝ	215

ΑΚΡΥΛΙΚΕΣ ΒΑΦΕΣ

216-217



**ΑΓΚΥΡΑ ΣΠΑΣΤΗ
ΟΜΠΡΕΛΑ ΓΑΛΒΑΝΙΖΕ**

01.007	0,75kg
01.015	1,5 kg
01.025	2,5 kg
01.032	3,2 kg
01.040	4,0 kg
01.060	6,0 kg
01.080	8,0 kg
01.100	10,0 kg



**ΑΓΚΥΡΑ ΣΠΑΣΤΗ
ΟΜΠΡΕΛΑ INOX SS316**

01.207	0,75 kg
01.215	1,5 kg
01.225	2,5 kg
01.232	3,2 kg
01.240	4,0 kg



**ΑΓΚΥΡΑ ΤΥΠΟΥ
DANFORTH ΓΑΛΒΑΝΙΖΕ**

04.005	4,0 kg
04.006	6,0 kg
04.008	8,0 kg
04.010	10,0 kg
04.015	15,0 kg
04.020	20,0 kg
04.025	25,0 kg
04.030	30,0 kg



**ΑΓΚΥΡΑ ΤΕΣΣΑΡΟΧΑΛΙ
ΓΑΛΒΑΝΙΖΕ**

06.101	1,0 kg
06.102	2,0 kg
06.103	3,0 kg
06.104	4,0 kg
06.006	6,0 kg
06.008	8,0 kg
06.010	10,0 kg
06.012	12,0 kg
06.015	15,0 kg
06.020	20,0 kg
06.025	25,0 kg
06.030	30,0 kg



**ΑΓΚΥΡΑ ΤΥΠΟΥ
BRUCE INOX SS316**

03.102	2,0 kg
03.103	3,5 kg
03.105	5,0 kg
03.175	7,5 kg
03.110	10,0 kg
03.115	15,0 kg



**ΑΓΚΥΡΑ ΤΥΠΟΥ
BRUCE ΓΑΛΒΑΝΙΖΕ**

03.002	2,0 kg
03.003	3,5 kg
03.005	5,0 kg
03.075	7,5 kg
03.010	10,0 kg
03.015	15,0 kg
03.020	20,0 kg
03.025	25,0 kg
03.030	30,0 kg



**ΑΓΚΥΡΑ ΚΑΒΟΥΡΙ
ΒΑΡΕΩΣ ΤΥΠΟΥ
ΓΑΛΒΑΝΙΖΕ**

02.110	10,0 kg
02.116	16,0 kg
02.025	25,0 kg
02.035	34,0 kg
02.050	50,0 kg
02.075	75,0 kg



**ΤΕΣΣΑΡΟΧΑΛΙ INOX
ΠΕΤΑΧΤΑΡΙ**

06.105	0,4 kg
06.106	1,0 kg



**ΑΓΚΥΡΑ ΚΑΒΟΥΡΙ
ΓΑΛΒΑΝΙΖΕ Ε.Τ.**

02.002	2,5 kg
02.004	4,0 kg
02.006	6,0 kg
02.008	8,0 kg
02.010	10,0 kg
02.012	12,0 kg



**ΑΓΚΥΡΑ ΤΥΠΟΥ DELTA
INOX SS316**

03.605	5,0 kg
03.607	7,5 kg
03.610	10,0 kg
03.615	15,0 kg



**ΑΓΚΥΡΑ ΤΥΠΟΥ CQR
ΓΑΛΒΑΝΙΖΕ**

02.005	5,0 kg
02.007	7,0 kg
02.009	9,0 kg
02.011	12,0 kg
02.016	16,0 kg



ΑΓΚΥΡΑ BRITANY

03.906	6,0 kg
03.908	8,0 kg
03.910	10,0 kg
03.912	12,0 kg
03.914	14,0 kg
03.916	16,0 kg

ΑΓΚΥΡΑ DELTA TORO ΓΑΛΒΑΝΙΖΕ



ΚΩΔΙΚΟΣ	ΚΙΛΑ kg	ΑΛΥΣΙΔΑ mm	Amm	Bmm	Cmm	ΜΗΚΟΣ ΣΚΑΦΟΥΣ mt
03.704	4	6	515	230	8	<6,5
03.706	6	6	595	265	10	<8,7
03.710	10	8	695	310	13	<11,5
03.716	16	8	810	360	13	<15
03.720	20	10	880	390	16	<16
03.725	25	10	940	415	16	<18
03.732	32	10	1050	435	20	<21
03.740	40	10	1100	490	20	<23
03.750	50	12	1175	523	20	<25
03.763	63	12	1270	567	20	<28

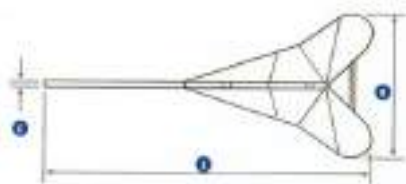

ΑΓΚΥΡΑ DELTA TORO INOX

ΚΩΔΙΚΟΣ	ΚΙΛΑ kg	ΑΛΥΣΙΔΑ mm	Amm	Bmm	Cmm	ΜΗΚΟΣ ΣΚΑΦΟΥΣ mt
03.624	4	6	515	230	8	<6,5
03.626	6	6	595	265	10	<8,7
03.630	10	8	695	310	13	<11,5
03.636	16	8-10	810	360	13	<15
03.640	20	10	880	390	16	<16
03.645	25	10-12	940	415	16	<18
03.652	32	10-12	1050	435	20	<21



ΑΓΚΥΡΑ INOX ULTRA

ΚΩΔΙΚΟΣ	ΚΙΛΑ kg	ΑΛΥΣΙΔΑ mm	ΜΗΚΟΣ ΣΚΑΦΟΥΣ mt
05.405	5	6	<5,7
05.408	8	6	<8
05.412	12	6	<10
05.416	16	6-8	<12
05.421	21	8	<14
05.427	27	8-10	<16
05.435	35	10	<18
05.445	45	10-12	<20
05.460	60	12-14	<23
05.480	80	14	<26



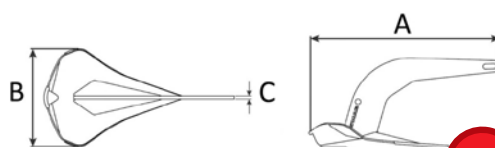

NEW

ΑΓΚΥΡΑ BULL GEN II



ΓΑΛΒΑΝΙΖΕ HDG	INOX SS316	ΚΙΛΑ	ΑΛΥΣΙΔΑ (mm)	A (mm)	B (mm)	C (mm)
03.801	03.921	6	6	486	271	8
03.802	03.922	10	8	573	332	10
03.803	03.923	16	8	670	376	12
03.804	03.924	20	10	720	406	12
03.805	03.925	25	10	778	438	16
03.806	03.926	32	10	839	474	16
03.807	03.927	40	10	907	512	20
03.808	03.928	50	12	974	550	20
03.809	03.929	63	12	1049	595	20



ΑΛΥΣΙΔΑ ΙΝΟΧ ΚΑΛΙΜΠΡΕ SS316 (ΓΙΑ ΕΡΓΑΤΗ)

ΚΩΔΙΚΟΣ	ΔΙΑΜΕΤΡΟΣ
05.106	6mm
05.108	8mm
05.110A P28	10mm DIN 766
05.110B P30	10mm ISO4565
05.112	12mm



ΑΛΥΣΙΔΑ ΓΑΛΒΑΝΙΖΕ ΚΑΛΙΜΠΡΕ "ΤΟΡΟ" (ΓΙΑ ΕΡΓΑΤΗ)

ΚΩΔΙΚΟΣ	ΔΙΑΜΕΤΡΟΣ	ΒΑΡΟΣ
05.006	6mm	0,8kg/m
05.008	8mm	1,4kg/m
05.010A P28	10mm DIN 766	2,2kg/m
05.010B P30	10mm ISO 4565	2,2kg/m
05.012	12mm	3,2kg/m
05.014	14mm	4,4kg/m
05.016	16mm	5,7kg/m
05.018	18mm	7,3kg/m



ΕΝΔΕΙΚΤΙΚΑ ΑΛΥΣΙΔΑΣ COLOUR: BLUE-GREEN-WHITE-RED-YELLOW

90.019	6mm	14 τεμ.
90.020	8mm	10 τεμ.
90.021	10mm	8 τεμ.
90.022	12mm	8 τεμ.



ΕΝΩΤΙΚΟ ΑΛΥΣΙΔΑΣ ΙΝΟΧ

05.217	6mm
05.218	8mm
05.219	10mm
05.220	12mm



ΓΑΝΤΖΟΣ ΣΥΓΚΡΑΤΗΣΗΣ ΑΛΥΣΙΔΑΣ

90.017	6-8mm
90.018	10-12mm



ΓΑΤΖΟΣ ΑΠΕΛΕΥΘΕΡΩΣΗΣ ΑΓΚΥΡΑΣ-ΑΛΥΣΙΔΑΣ

SS 316



ΕΝΩΤΙΚΟ ΑΛΥΣΙΔΑΣ ΓΑΛΒΑΝΙΖΕ

05.213	6mm
05.214	8mm
05.215	10mm
05.216	13mm
05.221	16mm



90.006

ΓΑΝΤΖΟΣ ΑΠΕΛΕΥΘΕΡΩΣΗΣ ΑΓΚΥΡΑ-ΑΛΥΣΙΔΑΣ





**ΝΑΥΤΙΚΟ ΚΛΕΙΔΙ
ΓΑΛΒΑΝΙΖΕ**

10.001	No1	5mm
10.002	No2	6mm
10.003	No3	8mm
10.004	No4	10mm
10.005	No5	12mm
10.006	No6	14mm
10.007	No7	16mm
10.008	No8	18mm
10.009	No9	20mm



**ΝΑΥΤΙΚΟ ΚΛΕΙΔΙ
ΙΝΟΧ**

10.101	No1	4mm
10.102	No2	5mm
10.103	No3	6mm
10.104	No4	8mm
10.105	No5	10mm
10.106	No6	12mm
10.107	No7	14mm
10.108	No8	16mm



**ΝΑΥΤΙΚΟ ΚΛΕΙΔΙ
Ω ΓΑΛΒΑΝΙΖΕ**

10.205	5mm
10.206	6mm
10.208	8mm
10.209	10mm
10.210	12mm
10.214	14mm
10.216	16mm
10.218	18mm
10.220	20mm
10.222	22mm
10.225	25mm
10.228	28mm
10.232	32mm



**ΝΑΥΤΙΚΟ ΚΛΕΙΔΙ
Ω ΙΝΟΧ**

10.305	5mm
10.306	6mm
10.308	8mm
10.310	10mm
10.312	12mm
10.314	14mm
10.316	16mm
10.318	18mm
10.320	20mm
10.322	22mm
10.324	25mm
10.328	28mm



ΑΓΚΙΣΤΡΟ ΓΑΛΒΑΝΙΖΕ

07.005	No1	5mm
07.006	No2	6mm
07.007	No3	8mm
07.009	No4	10mm
07.010	No5	12mm



ΑΓΚΙΣΤΡΟ ΙΝΟΧ

08.005	No1	5mm
08.006	No2	6mm
08.008	No3	8mm
08.010	No4	10mm
08.011	No5	12mm



ΑΓΚΙΣΤΡΟ ΜΕ ΑΣΦΑΛΕΙΑ

08.031	No1	6mm
08.032	No2	8mm
08.033	No3	10mm
08.034	No4	12mm



**ΝΑΥΤΙΚΟ ΚΛΕΙΔΙ
ΤΕΣΤΑΡΙΣΜΕΝΟ**

ΚΩΔΙΚΟΣ	ΔΙΑΣΤΑΣΗ	Ø mm
11.312	1/2"	12
11.316	5/8"	16
11.319	3/4"	19
11.322	7/8"	22
11.325	1"	25
11.328	1"1/8	28
11.332	1"1/4	32



**ΝΑΥΤΙΚΟ ΚΛΕΙΔΙ
ΜΑΚΡΥ**

NEW

ΚΩΔ.	ΔΙΑΣΤΑΣΗ (mm)
12.730	4
12.731	6
12.732	8
12.733	10
12.734	12



**ΝΑΥΤΙΚΟ ΚΛΕΙΔΙ
ΣΤΡΙΦΤΟ**

NEW

ΚΩΔ.	ΔΙΑΣΤΑΣΗ (mm)
12.721	4
12.722	6
12.723	8
12.724	10
12.725	12



**ΑΓΚΙΣΤΡΟ
ΑΣΦΑΛΕΙΑΣ ΙΝΟΧ**

08.020	6mm
08.021	8mm
08.022	10mm
08.023	12mm



**ΑΓΚΙΣΤΡΟ ΙΝΟΧ
ΜΕ ΕΛΑΣΜΑ**

08.041	50mm
08.042	70mm
08.043	100mm



**ΝΑΥΤΙΚΟ ΚΛΕΙΔΙ
ΕΝΩΣΗΣ ΑΓΚΥΡΑΣ ΜΕ ΑΛΛΕΝ**

ΚΩΔΙΚΟΣ	Ø mm
12.706	6
12.708	8
12.710	10
12.712	12



ΣΤΡΙΦΤΑΡΙ ΜΑΤΙ-ΜΑΤΙ ΓΑΛΒΑΝΙΖΕ

01.508	8mm
01.509	10mm
01.510	12mm
01.511	16mm
01.512	19mm



ΣΤΡΙΦΤΑΡΙ ΜΑΤΙ-ΚΡΙΚΟΣ ΓΑΛΒΑΝΙΖΕ

01.601	8mm
01.602	10mm
01.603	12mm
01.604	16mm
01.605	19mm



ΣΤΡΙΦΤΑΡΙ ΚΛΕΙΔΙ-ΚΛΕΙΔΙ INOX SS316

01.201	6mm
01.202	8mm
01.203	10mm
01.204	12mm



ΣΤΡΙΦΤΑΡΙ INOX ΜΑΤΙ-ΜΑΤΙ SS316

01.301	6mm
01.302	8mm
01.303	10mm
01.304	12mm



ΣΤΡΙΦΤΑΡΙ ΜΑΤΙ-ΚΛΕΙΔΙ INOX SS316

01.400	5mm
01.401	6mm
01.402	8mm
01.403	10mm



ΣΤΡΙΦΤΑΡΙ ΑΓΚΥΡΑΣ ΣΠΑΣΤΟ SS316 INOX

01.318	6-8mm
01.322	10-12mm



ΣΤΡΙΦΤΑΡΙ ΑΓΚΥΡΑΣ ΛΟΞΟ INOX SS316

90.014	6-8mm
90.015	10-12mm



ΣΤΡΙΦΤΑΡΙ ΑΓΚΥΡΑΣ SS316 INOX

01.311	6-8mm
01.409	10-12mm
01.410	14-16mm



SNAP SHACKLE INOX

ΚΩΔ.	ΔΙΑΣΤΑΣΗ (mm)
01.701	12
01.702	16
01.703	22



SNAP SHACKLE ΚΛΕΙΔΙ

ΚΩΔ.	ΔΙΑΣΤΑΣΗ (mm)
01.711	12
01.712	16
01.713	22

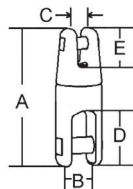

ΣΤΡΙΦΤΑΡΙ ΑΓΚΥΡΑΣ SS316 INOX MT

ΚΩΔ.	A (mm)	B (mm)	C (mm)	D (mm)	E (mm)	S.W.L. kg	ΑΛΥΣΙΔΑ (mm)
90.010	78	15	9	35	22	850	6-8
90.011	90	22	13	41	24	1350	10-12



ΣΤΡΙΦΤΑΡΙ ΚΟΝΓ

ΚΩΔ.	Load (Kgf)	ΑΛΥΣΙΔΑ (mm)
01.421	240	6÷8
01.422	550	8÷12
01.423	2350	12÷14



ΣΦΥΚΤΗΡΑΣ ΓΑΛΒΑΝΙΖΕ

01.404	4,0mm
10.260	5,0mm
10.265	6,5mm
10.280	8,0mm
10.285	10,0mm
10.295	12,0mm
10.296	16,0mm
10.297	19,0mm
10.298	26,0mm
10.299	30,0mm



ΣΦΥΚΤΗΡΑΣ INOX

10.371	6,0mm
10.372	8,0mm
10.373	10,0mm
10.374	12,0mm



ΣΤΡΙΦΤΑΡΙ ΑΓΚΥΡΑΣ ULTRA FLIP

ΚΩΔ.	ΑΛΥΣΙΔΑ (mm)
01.351	6
01.352	8
01.353	10
01.354	12



SOFT SHACKLE

ΚΩΔ.	ΔΙΑΜΕΤΡΟΣ (mm)	ΜΗΚΟΣ (mm)
13.706	6	10
13.708	8	10
13.710	10	15
13.712	12	15
13.714	14	15



**ΡΑΟΥΛΟ ΔΙΠΛΟ
WHALE INOX**

- 10.116** L330xW70mm
- 10.117** L400xW70mm
- 10.118** L495xW90mm
- 10.123** L595xW90mm
- 10.124** L695xW90mm



**ΡΑΟΥΛΟ ΔΙΠΛΟ
ΑΓΚΥΡΑΣ ΜΟΡΑΥ INOX**

- 10.111** L300xW80mm
- 10.112** L400xW80mm
- 10.113** L500xW80mm



**10.125
ΑΝΤ/ΚΟ ΓΙΑ ΔΙΠΛΟ
ΡΑΟΥΛΟ INOX**

- A** 55mm
- B** 70mm
- C** 75mm



**ΡΑΟΥΛΟ ΑΓΚΥΡΑΣ
ΜΟΝΟ INOX**

- 10.721** L300xW80mm
- 10.722** L400xW80mm
- 10.723** L500xW80mm

ΡΑΟΥΛΟ ΠΛΩΡΗΣ ΜΕ ΣΦΙΓΚΤΗΡΑ



ΚΩΔΙΚΟΣ	Amm	Bmm	Cmm	Lmm	ΑΓΚΥΡΑ kg
10.131	620	300	200	83	6-10
10.132	670	340	170	85	16-25

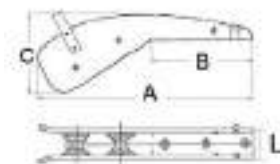

ΡΑΟΥΛΟ ΠΛΩΡΗΣ ΣΠΑΣΤΟ



ΚΩΔΙΚΟΣ	Amm	Bmm	Cmm	Dmm
10.134	225	415	76	150
10.135	390	585	80	265

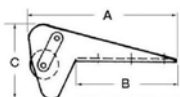
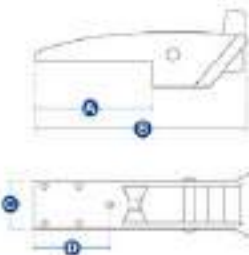

ΡΑΟΥΛΟ INOX ΓΙΑ BRUCE

ΚΩΔ.	A (mm)	B (mm)	C (mm)	L (mm)	ΑΓΚΥΡΑ (kg)
10.126	380	261	196	67	10
10.127	480	300	240	75	15
10.128	590	340	235	78	20



ΡΑΟΥΛΟ ΠΛΩΡΗΣ INOX

- 10.711** L150xW50mm
- 10.712** L200xW50mm
- 10.713** L250xW50mm



ΡΑΟΥΛΟ ΠΛΩΡΗΣ INOX

- 11.517** L150 x W50mm



ΡΑΟΥΛΟ ΠΛΩΡΗΣ INOX

- 11.519** L210 x W45mm



**ΡΑΟΥΛΟ ΠΛΩΡΗΣ ΜΕ
ΠΥΡΟ INOX**

- 11.518** L200 x W50mm



**ΡΑΟΥΛΟ ΠΛΩΡΗΣ
ΜΕ ΑΣΦΑΛΕΙΑ**

- 11.520** L270 x W50mm



10.115

**ΡΑΟΥΛΟ ΠΛΩΡΗΣ L
393 x W 52 mm**



10.734

**ΡΑΟΥΛΟ ΘΡΘΙΟ ΑΓΚΥΡΑΣ
INOX L140mm**



ΡΟΔΑΚΙ ΓΙΑ ΡΑΟΥΛΟ

- 10.415** L70xW62 mm
- 10.416** L54xW48 mm
- 10.417** L54xW62 mm



ΡΑΟΥΛΟ ΠΛΩΡΗΣ

- 10.714** 220 x W50mm



ΕΛΑΤΗΡΙΟ/ΛΑΣΤΙΧΟ ΓΙΑ ΣΧΟΙΝΙ

ΚΩΔΙΚΟΣ	Ø ΣΧΟΙΝΙΟΥ	ΟΡΙΟ ΘΡΑΥΣΗΣ
12.621	10-12mm	218kg
12.622	12-14mm	450kg
12.623	14-18mm	710kg



ΕΛΑΤΗΡΙΟ Β.Τ. ΙΝΟΧ

10.300	Φ5 x L270mm
10.301	Φ6 x L315mm
10.302	Φ7 x L335mm
10.303	Φ9 x L430mm
10.304	Φ12 x L370mm



ΕΛΑΤΗΡΙΟ ΙΝΟΧ

12.606	Φ6xL320mm
12.607	Φ7xL340mm
12.609	Φ9xL430mm
12.610	Φ11xL380mm



ΕΛΑΤΗΡΙΟ ΓΑΛΒΑΝΙΖΕ

12.511	Φ6,5 x L320mm
12.512	Φ8,0 x L370mm
12.513	Φ10 x L405mm
12.514	Φ12 x L380mm



12.531



12.534



12.532-3



12.535

ΕΛΑΤΗΡΙΑ SIDERMARINE

ΚΩΔΙΚΟΣ	ΜΗΚΟΣ ΣΚΑΦΟΥΣ m	ΔΙΑΜ. ΕΛΑΤΗΡΙΟΥ mm	BREAKING LOAD kg	ΒΑΡΟΣ ΣΚΑΦΟΥΣ kg
12.531	7	5	2000	1200
12.532	7-9	7	3000	1800
12.533	8-11	8	4000	2400
12.534	12-20	12	8000	16000
12.535	16-28	12	11000	20000



98.101
ΡΕΛΕ ΕΡΓΑΤΗ 500-700W



98.102
ΡΕΛΕ ΕΡΓΑΤΗ 1000W



16.177
ΟΡΓΑΝΟ ΜΕΤΡΗΣΗΣ
ΑΛΥΣΙΔΑΣ ΜΖ



ΧΕΙΡΙΣΤΗΡΙΟ ΠΟΔΙΟΥ
ΕΡΓΑΤΗ ΑΓΚΥΡΑΣ

16.175 ΚΟΚΚΙΝΟ
16.176 ΜΑΥΡΟ



ΑΣΦΑΛΕΙΑ ΘΕΡΜΙΚΗ ΕΡΓΑΤΗ

98.168A	60A	98.179A	60A
98.168B	80A	98.179B	80A
98.168C	120A	98.179C	120A
98.168D	150A	98.179D	150A
98.168E	200A	98.179E	200A



10.380
ΜΑΝΙΤΑΡΙ ΔΙΑΝΟΜΗΣ ΑΛΥΣΙΔΑΣ



16.172
ΧΕΙΡΙΣΤΗΡΙΟ ΕΡΓΑΤΗ WIRELESS
ΜΕ ΜΕΤΡΗΤΗ ΚΑΔΕΝΑΣ



16.173
ΧΕΙΡΙΣΤΗΡΙΟ ΕΡΓΑΤΗ
ΑΓΚΥΡΑΣ



16.174
ΧΕΙΡΙΣΤΗΡΙΟ ΕΡΓΑΤΗ
3 ΘΕΣΕΩΝ WIRELESS



45.000
ΠΡΟΣΤΑΤΕΥΤΙΚΟ ΙΝΟΧ
ΠΛΩΡΗΣ ΜΙΚΡΟ
L26xH34cm



45.001
ΠΡΟΣΤΑΤΕΥΤΙΚΟ ΙΝΟΧ
ΠΛΩΡΗΣ ΜΕΓΑΛΟ
L35xH34cm



45.002
ΠΡΟΣΤΑΤΕΥΤΙΚΟ ΙΝΟΧ
ΠΛΩΡΗΣ ΜΕΓΑΛΟ ΜΕ ΤΡΥΠΑ
L32xH28cm



ΕΡΓΑΤΗΣ ΑΓΚΥΡΑΣ ΙΝΟΧ

ΚΩΔ.	MODEL	WATT	VOLT	ΑΛΥΣΙΔΑ	ΜΕΓΙΣΤΟ ΦΟΡΤΙΟ	ΤΑΧΥΤΗΤΑ ΠΤΩΣΗΣ	ΒΑΡΟΣ kg
98.091	SMART	500	12	6mm	270kg	23 m/min	8.5/9.5
98.291	SMART BLACK	500	12	6mm	270kg	23 m/min	8.5/9.5
98.095A	SMART	700	12	6mm	300kg	25 m/min	8.5/9.5
98.095B	SMART	700	12	8mm	300kg	25 m/min	8.5/9.5
98.092	SMART PLUS	1000	12	8mm	390kg	25 m/min	12.5
98.104	SMART PLUS	1500	12	10mm	450kg	23 m/min	18
98.105	SMART PLUS	1500	24	10mm	480kg	23 m/min	18
98.094	SMART ΜΕ ΚΑΜΠΑΝΑ	500	12	6mm	270kg	23 m/min	10
98.099	SMART ΜΕ ΚΑΜΠΑΝΑ	700	12	8mm	300kg	25 m/min	10
98.092A	SMART PLUS ΜΕ ΚΑΜΠΑΝΑ	1000	12	8mm	420kg	25 m/min	13

ΕΡΓΑΤΗΣ ΑΓΚΥΡΑΣ ΟΒΙ



ΚΩΔΙΚΟΣ	WATT	VOLT	ΑΛΥΣΙΔΑ	ΜΕΓΙΣΤΟ ΦΟΡΤΙΟ	ΤΑΧΥΤΗΤΑ ΠΤΩΣΗΣ	kg
98.093	500	12	6 mm	280 kg	23 m/min	8.5/9.5
98.096	700	12	6 mm	350 kg	25 m/min	8.5/9.5

ΕΡΓΑΤΗΣ ΑΓΚΥΡΑΣ DEVON



ΚΩΔΙΚΟΣ	WATT	VOLT	ΑΛΥΣΙΔΑ	ΜΕΓ.ΔΥΝΑΜΗ	ΔΥΝΑΜΗ	kg
98.111	1000	12	8 mm	450 kg	150 kg	28
98.112	1000	24	8 mm	480 kg	150 kg	28
98.113	1500	12	10 mm	540 kg	180 kg	30
98.114	1500	24	10 mm	570 kg	190 kg	30

BOWTHRUSTERS



ΚΩΔΙΚΟΣ	ΠΡΟΠΕΛΑ	ΜΗΚΟΣ ΣΚΑΦΟΥΣ m/ft	ΔΥΝΑΜΗ kW	TUNEL mm	VOLT v	FORCE kgf
17.701	ΜΟΝΗ	6.5-10 / 21-33	2.2	125	12	40
17.702	ΔΙΠΛΗ	8.5-12 / 28-41	3.0	150	12	60
17.703A	ΜΟΝΗ	10.5-15 / 34-49	4.4	185	12	80
17.703B	ΜΟΝΗ	10.5-15 / 34-49	4.4	185	24	80
17.714	ΔΙΠΛΗ	11-15.5 / 36-51	4.7	185	12	90
17.715	ΔΙΠΛΗ	11.5-16 / 38-52	5.7	185	12	100
17.716	ΔΙΠΛΗ	11.5-16 / 38-52	5.7	185	24	100

ΚΑΡΒΟΥΝΑΚΙΑ BOWTHRUSTER



ΚΩΔΙΚΟΣ	BOWTHRUSTER	ΣΥΣΚΕΥΑΣΙΑ
17.731	40kgf	4 τεμ
17.732	60-80kgf	8 τεμ
17.733	90-100kgf	8 τεμ



17.710

BOW THRUSTER JOYSTICK ΠΑΝΕΛ



17.712

BOW THRUSTER ΠΑΝΕΛ



ΠΡΟΠΕΛΑ BOWTHRUSTER

17.720 T185mm

17.721 T150mm

17.722 T125mm



17.711

ΠΑΝΕΛ JOYSTICK INOX
ΓΙΑ BOWTHRUSTER



17.713

ΠΑΝΕΛ ΑΦΗΣ INOX
ΓΙΑ BOWTHRUSTER



STERN THRUSTER

17.901 40kg Φ125mm

17.902 60kg Φ150mm

17.903 80kg Φ185mm

17.904 90kg Φ185mm



BOWTHRUSTER ΤΟΥΝΕΛ

17.704 125mm 1.0mt

17.705 150mm 1.0mt

17.706 180mm 1.0 mt

17.726 180mm 1.5 mt



ΚΑΛΩΔΙΟ ΜΕ ΦΙΣ
BOWTHRUSTER

17.707 7mct

17.708 10mt

17.709 15mt



28.100

ΗΛΕΚΤΡΙΚΗ (ΑΓΚΥΡΑ) ΜΗΧΑΝΗ CAYMAN-B 55LBS ΛΕΥΚΗ GPS ΜΕ ΒΑΣΗ

Τεχνικά Χαρακτηριστικά:

- Μοντέλο: 50736-137 • Χρώμα: Λευκό
- Ισχύς Κινητήρα: 540W – 660W
- Ισχύς / Διάτμησης (Kg / W): σε 24,6 Kg Ώθησης -55 Lbs
- Τάση Λειτουργίας: 12V DC
- Ρύθμιση Ταχύτητας: 10 επίπεδα
- Βάρος Μηχανής: 15,5 κ,
- Προτεινόμενο Μήκος Σκάφους: 5,5μ
- Μήκος Άξονα (ολικό): 152mm
- Χειρισμός: Ασύρματος
- Ένδειξη Μπαταρίας: 5 Φωτεινές Ενδείξεις Led



ΒΑΣΗ ΓΡΗΓΟΡΗΣ ΑΠΕΛΕΥΘΕΡΩΣΗΣ CAYMAN

28.103A 55LBS

28.103B 80LBS

28.101

ΗΛΕΚΤΡΙΚΗ (ΑΓΚΥΡΑ) ΜΗΧΑΝΗ CAYMAN-B 80LBS ΛΕΥΚΗ GPS ΜΕ ΒΑΣΗ

Τεχνικά Χαρακτηριστικά:

- Μοντέλο: 50739 • Χρώμα: Λευκό
- Ισχύς Κινητήρα: 1080W
- Ισχύς / Διάτμησης (Kg / W): σε 24,6 Kg Ώθησης -80 Lbs
- Τάση Λειτουργίας: 24V DC
- Ρύθμιση Ταχύτητας: 10 επίπεδα
- Βάρος Μηχανής: 15,5 κ,
- Προτεινόμενο Μήκος Σκάφους: 5,5μ
- Μήκος Άξονα (ολικό): 183mm
- Χειρισμός: Ασύρματος
- Ένδειξη Μπαταρίας: 5 Φωτεινές Ενδείξεις Led



28.105

ΗΛΕΚΤΡΙΚΗ ΑΓΚΥΡΑ ΜΑΚΟΣHARK

Series	OMAS	
Model	28.105	28.107
Voltage (V)	12	24
Max Current(A)	55	55
Power (W)	660	1320
Thrust	55lbs	86lbs
Speed(Km/h)	9	10
Suggested Battery	12V*100AH	24V*100AH
Speed mode	Remote Control	RemoteControl
Product Des.	GPS Remote Control with Screen Brush Motor	GPS Remote Control with Screen Brush Motor
Shaft L	152cm	183cm
Shaft Material	SS304	SS304
Weight (kgs)	22.3	22.5



28.109

ΒΑΣΗ ΓΡΗΓΟΡΗΣ ΑΠΕΛΕΥΘΕΡΩΣΗΣ ΜΑΚΟΣHARK



28.111

ΚΟΝΤΡΟΛ ΗΛΕΚΤΡΙΚΗΣ ΑΓΚΥΡΑΣ ΜΑΚΟΣHARK



ΣΧΟΙΝΙ ΤΡΙΚΛΩΝΟ ΒΥΘΙΖΟΜΕΝΟ ΔΙΠΛΗΣ ΣΤΡΕΨΗΣ (MEDIUM TENACITY)

ΛΕΥΚΟ	ΜΑΥΡΟ	ΜΠΛΕ	ΔΙΑΜ.	ΜΗΚΟΣ	ΟΡΙΟ ΘΡΑΥΣΗΣ
11.406	11.606	11.706	6 mm	200m	600 kg
11.408	11.608	11.708	8 mm	200m	1070 kg
11.410	11.610	11.710	10 mm	200m	1650 kg
11.412	11.612	11.712	12 mm	150m	2340 kg
11.414	11.614	11.714	14 mm	100m	3150 kg
11.416	11.616	11.716	16 mm	100m	4060 kg
11.418	11.618	11.718	18 mm	100m	5090 kg
11.420	11.620	11.720	20 mm	100m	6220 kg
11.422	11.622	11.722	22 mm	100m	7450 kg
11.424	11.624	11.724	24 mm	100m	8970 kg
11.426	11.626	11.726	26 mm	100m	10290 kg
11.428	11.628	11.728	28 mm	100m	11830 kg
11.430	11.630	-	30 mm	100m	13500 kg
11.432	11.632	-	32 mm	100m	15300 kg
11.434	11.634	-	34 mm	100m	17100 kg
11.436	11.636	-	36 mm	100m	19170 kg
11.438	-	-	38 mm	100m	21080 kg
11.440	-	-	40 mm	100m	23450 kg



ΣΧΟΙΝΙ ΠΛΕΚΤΟ ΡΙΓΑ ΒΥΘΙΖΟΜΕΝΟ ΙΤΑΛΙΑΣ

ΚΟΚΚΙΝΟ	ΜΠΛΕ	ΔΙΑΜ. mm	ΜΗΚΟΣ mm
11.003*	11.003*	3	800
11.004A	11.004B	4	400
11.005A	11.005B	5	200
11.006A	11.006B	6	300
11.008A	11.008B	8	300
11.010A	11.010B	10	200
11.012A	11.012B	12	150
11.014A	11.014B	14	100
11.016A	11.016B	16	100
11.018A	11.018B	18	100
11.020A	11.020B	20	100
11.022A	11.022B	22	100
11.024A	11.024B	24	100

*ΛΕΥΚΟ



ΣΧΟΙΝΙ ΑΦΡΟΥ 12-ΚΛΩΝΟ ΜΕΓΑΛΗΣ ΑΝΤΟΧΗΣ

ΚΩΔΙΚΟΣ	ΔΙΑΜΕΤΡΟΣ mm	ΒΑΡΟΣ kg/100mt	ΟΡΙΟ ΘΡΑΥΣΗΣ kg
12.312	12	6.60	2.350
12.314	14	8.90	3.350
12.316	16	11.50	4.500
12.318	18	15.10	5.500
12.320	20	18.80	6.800
12.322	22	22.20	7.900
12.324	24	26.00	9.300
12.326	26	30.80	11.000
12.328	28	35.50	13.100
12.330	30	41	14.750
12.332	32	46	16.900
12.334	34	48	21.100
12.336	36	51	23.000



ΙΜΑΝΤΑΣ ΔΙΠΛΟΣ
 21.145 50mm 5mt
 21.146 50mm 8mt



ΙΜΑΝΤΑΣ ΔΙΠΛΟΣ
 21.147 75mm 5mt
 21.148 75mm 8mt

ΣΧΟΙΝΙ ΠΟΛΥΕΣΤΕΡΙΚΟ 8-ΚΛΩΝΟ ΜΕΓΑΛΗΣ ΑΝΤΟΧΗΣ



ΚΩΔΙΚΟΣ	ΔΙΑΜ. mm	ΜΗΚΟΣ mt	ΟΡΙΟ ΘΡΑΥΣΗΣ kg
13.312	12	200	2.020
13.314	14	200	2.700
13.316	16	100	3.200
13.318	18	100	3.860
13.320	20	100	4.200
13.322	22	100	4.650
13.324	24	100	5.300



ΣΧΟΙΝΙ 24-ΚΛΩΝΟ ΑΦΡΟΥ ΚΙΤΡΙΝΟ (BRADED)

ΚΩΔΙΚΟΣ	ΔΙΑΜ. mm	ΟΡΙΟ ΘΡΑΥΣΗΣ kg
13.212	12	2.400
13.214	14	3.450
13.216	16	4.600
13.218	18	5.600
13.220	20	6.950
13.222	22	7.950
13.224	24	9.400
13.226	26	11.100
13.228	28	13.250
13.230	30	13.900
13.232	32	14.950

ΣΧΟΙΝΙ ΠΟΛΥΕΣΤΕΡΙΚΟ 12-ΚΛΩΝΟ



ΜΑΥΡΟ	ΜΠΛΕ	ΓΚΡΙ	ΔΙΑΜ. mm	ΜΗΚΟΣ mt	B.L. kg
11.906	11.806	12.406	6	200	500
11.908	11.808	12.408	8	200	720
11.910	11.810	12.410	10	200	1200
11.912	11.812	12.412	12	200	1800
11.914	11.814	12.414	14	100	2000
11.916	11.816	12.416	16	100	2500
11.918	11.818	12.418	18	100	3200
11.920	11.820	12.420	20	100	3700
11.922	11.822	12.422	22	100	4200
11.924	11.824	12.424	24	100	4600
11.926	11.826	12.426	26	100	5100
11.928	11.828	12.428	28	100	7500



ΡΟΔΑΝΤΖΑ ΠΛΑΣΤΙΚΗ

09.004	4mm
09.006	6mm
09.008	8mm
09.010	10mm
09.012	12mm
09.014	14mm
09.016	16mm
09.018	18mm
09.020	20mm
09.022	22mm
09.024	24mm



ΡΟΔΑΝΤΖΑ ΙΝΟΧ SS316

09.106	6mm
09.108	8mm
09.110	10mm
09.112	12mm
09.114	14mm
09.116	16mm
09.118	18mm
09.120	20mm
09.122	22mm
09.124	24mm
09.126	26mm
09.128	28mm
09.130	30mm
09.132	32mm



ΡΟΔΑΝΤΖΑ ΓΑΛΒΑΝΙΖΕ

09.206	6mm
09.208	8mm
09.210	10mm
09.212	12mm
09.214	14mm
09.216	16mm
09.218	18mm
09.220	20mm
09.222	22mm
09.224	24mm
09.226	26mm
09.228	28mm
09.230	30mm
09.232	32mm
09.234	34mm



ΣΧΟΙΝΙ ΤΖΙΒΑ (ΥΤΑ)

ΚΩΔΙΚΟΣ	ΔΙΑΜ.
12.206	6mm
12.208	8mm
12.210	10mm
12.212	12mm
12.214	14mm
12.216	16mm
12.218	18mm
12.220	20mm
12.222	22mm
12.224	24mm
12.226	26mm
12.228	28mm
12.230	30mm
12.232	32mm



ΣΧΟΙΝΙ ΜULTI 3ΚΛΩΝΟ ΠΟΛΥΠΡΟΠΥΛΑΙΝΙΟ ΑΦΡΟΥ

ΚΩΔΙΚΟΣ	ΔΙΑΜ.
11.511	6mm
11.512	8mm
11.513	10mm
11.514	12mm



ΣΧΟΙΝΙ ΠΛΕΚΤΟ ΑΦΡΟΥ

ΔΙΑΜΕΤΡΟΣ	ΠΟΡΤΟΚΑΛΙ	ΜΑΥΡΟ	ΛΕΥΚΟ	ΓΚΡΙ
6mm	99.722	99.771	99.711	
8mm	99.721	99.772	99.712	
10mm	99.402	99.773	99.713	
12mm	99.403	99.774	99.714	99.405



ΣΧΟΙΝΙ ΨΥΧΑ ΔΥΝΕΕΜΑ ΧΩΡΙΣ ΚΑΛΥΜΑ ΑΝΘΡΑΚΙ

NEW

ΚΩΔ.	ΔΙΑΜΕΤΡΟΣ (mm)	ΟΡΙΟ ΘΡΑΥΣΗΣ kg
13.803	3	950
13.804	4	1400
13.805	5	2200
13.806	6	3200
13.808	8	5800
13.810	10	6400



ΣΧΟΙΝΙ 24ΚΛΩΝΟ ΠΟΛΥΕΣΤΕΡΙΚΟ ΧΩΡΙΣ ΨΥΧΑ

ΜΠΛΕ	ΜΑΥΡΟ	ΜΗΚΟΣ	ΔΙΑΜ. mm	ΟΡΙΟ ΘΡΑΥΣΗΣ kg
12.808A	12.808A	200	8	1.500
12.810A	12.810B	200	10	2.600
12.812A	12.812B	200	12	3.400
12.814A	12.814B	200	14	4.800
12.816A	12.816B	100	16	5.900
12.818A	12.818B	100	18	7.900
12.820A	12.820B	100	20	9.650
12.822A	12.822B	100	22	11.500
12.824A	12.824B	100	24	13.700
12.826A	12.826B	100	26	16.000
12.828A	12.828B	100	28	18.800
12.830A	12.830B	100	30	20.450
12.832A	12.832B	100	32	23.900



SOFT SHACKLE

NEW

ΚΩΔ.	ΔΙΑΜΕΤΡΟΣ (mm)	ΜΗΚΟΣ (mm)
13.706	6	10
13.708	8	10
13.710	10	15
13.712	12	15
13.714	14	15

ΣΧΟΙΝΙ ΙΣΤΙΟΠΛΟΪΑΣ ΠΟΛΥΕΣΤΕΡΙΚΟ 24-ΚΛΩΝΟ

ΜΠΕΖ	ΜΠΛΕ	ΚΟΚΚΙΝΟ	ΠΡΑΣΙΝΟ	ΓΚΡΙ	ΔΙΑΜ. mm	ΟΡΙΟ ΘΡΑΥΣΗΣ kg
12.906 A	12.906 B	12.906 C	12.906 D	12.906 E	6	700
12.908 A	12.908 B	12.908 C	12.908 D	12.908 E	8	1.400
12.910 A	12.910 B	12.910 C	12.910 D	12.910 E	10	1.700
12.912 A	12.912 B	12.912 C	12.912 D	12.912 E	12	2.100
12.914 A	12.914 B	12.914 C	12.914 D	12.914 E	14	2.600
12.916 A	12.916 B	12.916 C	12.916 D	12.916 E	16	3.250
12.918 A	12.918 B	12.918 C	12.918 D	12.918 E	18	4.000



ΣΧΟΙΝΙ ΙΣΤΙΟΠΛΟΙΑΣ ΔΥΝΕΕΜΑ 24-ΚΛΩΝΟ

ΜΠΕΖ	ΜΠΛΕ	ΚΟΚΚΙΝΟ	ΠΡΑΣΙΝΟ	ΔΙΑΜΕΤΡΟΣ mm	ΟΡΙΟ ΘΡΑΥΣΗΣ kg
13.906 A	13.906 B	13.906 C	13.906 D	6	1.500
13.908 A	13.908 B	13.908 C	13.908 D	8	2.300
13.910 A	13.910 B	13.910 C	13.910 D	10	3.100
13.912 A	13.912 B	13.912 C	13.912 D	12	4.800
13.914 A	13.914 B	13.914 C	13.914 D	14	6.500
13.916 A	13.916 B	13.916 C	13.916 D	16	8.100





**ΣΧΟΙΝΙ ΠΟΛΥΕΣΤΕΡΙΚΟ
12-ΚΛΩΝΟ ΜΕ ΓΑΣΑ ΜΑΥΡΟ**

ΚΩΔΙΚΟΣ	ΔΙΑΜΕΤΡΟΣ	ΜΗΚΟΣ
11.736	10mm	10m
11.738	12mm	10m
11.739	14mm	10m
11.742	16mm	10m
11.743	18mm	14m
11.744	20mm	14 m
11.745	22mm	14 m
11.746	24mm	14 m



**ΣΧΟΙΝΙ ΠΟΛΥΕΣΤΕΡΙΚΟ
12-ΚΛΩΝΟ ΜΕ ΓΑΣΑ ΜΠΛΕ**

ΚΩΔΙΚΟΣ	ΔΙΑΜΕΤΡΟΣ	ΜΗΚΟΣ
11.733	10mm	6m
11.734	12mm	10m
11.740	14mm	10m
11.741	16mm	10m



**ΣΧΟΙΝΙ ΤΡΙΚΛΩΝΟ ΜΑΥΡΟ
ΜΕ ΡΟΔΑΤΖΑ/ΓΑΛΒΑΝΙΖΕ**

ΚΩΔΙΚΟΣ	ΔΙΑΜ.	ΜΗΚΟΣ
11.750	10 mm	6 m
11.751	12 mm	9 m
11.752	14 mm	12 m
11.753	16 mm	12 m



**ΣΧΟΙΝΙ ΝΑΥΛΟΝ ΜΕΓΑΛΗΣ
ΑΝΤΟΧΗΣ ΓΙΑ ΨΑΡΕΜΑ (TRESSIA)**

ΚΩΔΙΚΟΣ	ΔΙΑΜΕΤΡΟΣ	ΜΗΚΟΣ
99.718	1,0 mm	500m
99.723	1,5 mm	500m
99.719	2,0 mm	500m
99.720	3,0 mm	500m



**ΣΧΟΙΝΙ ΠΟΛΥΠΡΟΠΥΛΑΙΝΙΟ
ΜΠΟΜΠΙΝΑ**

ΚΩΔΙΚΟΣ	ΔΙΑΜ.	ΜΗΚΟΣ
20.612	3 mm	17m
20.613	2 mm	30m
20.633	2 mm	100m
20.634	3 mm	100m



ΣΧΟΙΝΙ ΕΛΑΣΤΙΚΟ ΠΟΛΥΕΣΤΕΡΙΚΟ

ΚΩΔΙΚΟΣ	Α-ΛΕΥΚΟ	Β-ΚΟΚ.	Γ-ΜΑΥΡΟ	ΜΗΚΟΣ
11.504	4mm	4mm	4mm	100m
11.505	5mm	5mm	5mm	100m
11.506	6mm	6mm	6mm	100m
11.508	8mm	8mm	8mm	100m
11.510	10mm	10mm	10mm	100m



11.950
ΣΚΑΝΤΑΓΙΟ



99.756
ΚΙΤ ΕΠΙΣΚΕΥΗΣ ΠΑΝΙΩΝ



99.769
ΕΡΓΑΛΕΙΟ ΓΑΣΑΣ
ΣΧΟΙΝΙΟΥ



99.768
ΠΡΟΣΤΑΤΕΥΤΙΚΟ ΠΑΛΑΜΗΣ
ΓΙΑ ΓΑΣΑ



99.767
ΒΕΛΟΝΕΣ ΣΕΤ ΠΑΝΙΟΥ



99.780
ΠΡΟΣΤΑΤΕΥΤΙΚΟ ΣΧΟΙΝΙΩΝ
ΓΙΑ ΠΟΝΤΙΚΙΑ



99.997
ΒΙΛΑΙ ΔΕΡΜΑΤΙΝΟ



**ΓΑΝΤΖΟΣ ΠΛΑΣΤΙΚΟΣ
ΓΙΑ ΣΧΟΙΝΙ /ΛΑΣΤΙΧΟ**

ΚΩΔΙΚΟΣ	ΔΙΑΜ.
08.104	4mm
08.106	6mm
08.108	8mm
08.110	10mm

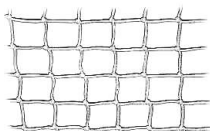

ΔΙΧΤΥ ΓΙΑ ΡΕΛΙΑ

ΚΩΔ.	ΠΕΡΙΓΡΑΦΗ	ΜΗΚΟΣ/ΥΨΟΣ mm
99.930	ΚΟΛΛΗΤΟ	30/45
99.931	ΜΕ ΚΟΜΠΟΥΣ	30/45



**ΛΑΣΤΙΧΟ ΔΕΣΙΜΑΤΟΣ
ΜΕ ΜΠΙΛΙΑ**

ΚΩΔΙΚΟΣ	ΔΙΑΜ.
97.119	30cm
97.120	40cm
97.121	50cm
97.122	60cm



ΕΛΙΑ ΓΙΑ ΛΑΣΤΙΧΟ

ΚΩΔΙΚΟΣ	ΔΙΑΜ.
97.133	6mm
97.134	8mm



96.413

ΠΡΟΣΤΑΤΕΥΤΙΚΟ ΣΧΟΙΝΙΟΥ ΥΦΑΣΜΑΤΙΝΟ COLUMBUS



11.642
**ΠΙΣΤΟΛΙ ΚΟΠΗΣ
(HOT KNIFE)**



11.645
ΑΝΤΑΛΑΚΤΙΚΟ HOT KNIFE



12.638
ΣΧΟΙΝΙ ΚΑΛΑΦΑΤΙΣΜΑΤΟΣ 8mm



99.997
ΒΙΛΑΙ ΔΕΡΜΑΤΙΝΟ



99.766
**ΝΗΜΑ MARLOW ΚΕΡΩΜΕΝΟ
Φ 0,4mm**



99.782
**ΚΙΤ ΜΕ ΒΕΛΟΝΕΣ ΓΙΑ ΓΑΣΑ
2 ΕΩΣ 20mm**

ΡΑΟΥΛΟ ΜΟΝΟ/ΣΤΡΙΦΤΑΡΙ



ΚΩΔΙΚΟΣ	ΤΡΟΧΑΛΙΑ mm	ΜΗΚΟΣ mm	ΣΧΟΙΝΙ mm	BREAK/LOAD kg
34.001	35	78	8	600
34.002	50	101	10	1050
34.003	60	114	12	1200
34.004	70	140	12	2000
34.005	90	188	14	3200

ΡΑΟΥΛΟ ΜΟΝΟ/ΣΤΡΙΦΤΑΡΙ/ΒΕΚΕΤ



ΚΩΔΙΚΟΣ	ΤΡΟΧΑΛΙΑ mm	ΜΗΚΟΣ mm	ΣΧΟΙΝΙ mm	BREAK/LOAD kg
34.111	35	94	8	600
34.112	50	120	10	1050
34.113	60	138	12	1200
34.114	70	168	12	2000
34.115	90	225	14	3200

ΡΑΟΥΛΟ ΔΙΠΛΟ ΣΤΡΙΦΤΑΡΙ



ΚΩΔΙΚΟΣ	ΤΡΟΧΑΛΙΑ mm	ΜΗΚΟΣ mm	ΣΧΟΙΝΙ mm	BREAK/LOAD kg
34.121	35	78	8	600
34.122	50	101	10	1050
34.123	60	114	12	1200
34.124	70	140	12	2000
34.125	90	188	14	3200

ΡΑΟΥΛΟ ΔΙΠΛΟ/ΣΤΡΙΦΤΑΡΙ/ΒΕΚΕΤ



ΚΩΔΙΚΟΣ	ΤΡΟΧΑΛΙΑ mm	ΜΗΚΟΣ mm	ΣΧΟΙΝΙ mm	BREAK/LOAD kg
34.131	35	94	8	600
34.132	50	120	10	1050
34.133	60	138	12	1200
34.134	70	168	12	2000
34.135	90	225	14	3200

ΡΑΟΥΛΟ ΣΤΡΙΦΤΑΡΙ/ΚΙΘΑΡΑ



ΚΩΔΙΚΟΣ	ΤΡΟΧΑΛΙΑ mm	ΜΗΚΟΣ mm	ΣΧΟΙΝΙ mm	BREAK/LOAD kg
34.141	35	94	8	600
34.142	50	130	10	1050
34.143	60	154	12	1200
34.144	70	190	12	2000
34.145	90	250	14	3200



NEW

34.301
ΦΡΕΝΟ ΣΧΟΙΝΙΟΥ
ΜΟΝΟ 8-14mm



NEW

34.302
ΦΡΕΝΟ ΣΧΟΙΝΙΟΥ
ΔΙΠΛΟ 8-14mm



NEW

34.303
ΦΡΕΝΟ ΣΧΟΙΝΙΟΥ
ΤΡΙΠΛΟ 8-14mm

ΡΑΟΥΛΟ ΣΤΡΙΦΤΑΡΙ ΚΙΘΑΡΑ ΒΕΚΕΤ

ΚΩΔΙΚΟΣ	ΤΡΟΧΑΛΙΑ mm	ΜΗΚΟΣ mm	ΣΧΟΙΝΙ mm	BREAK/LOAD kg
34.151	35	117	8	600
34.152	50	147	10	1050
34.153	60	178	12	1200
34.154	70	213	12	2000
34.155	90	280	14	3200



ΡΑΟΥΛΟ ΣΤΡΙΦΤΑΡΙ ΚΙΘΑΡΑ ΒΕΚΕΤ ΜΕ ΔΑΓΚΑΝΑ

ΚΩΔΙΚΟΣ	ΤΡΟΧΑΛΙΑ mm	ΜΗΚΟΣ mm	ΣΧΟΙΝΙ mm	BREAK/LOAD kg
34.161	35	117	8	600
34.162	50	147	10	1050
34.163	60	178	12	1200
34.164	70	213	12	2000
34.165	90	280	14	3200



ΡΑΟΥΛΟ ΣΤΡΙΦΤΑΡΙ ΒΕΚΕΤ ΜΕ ΔΑΓΚΑΝΑ

ΚΩΔΙΚΟΣ	ΤΡΟΧΑΛΙΑ mm	ΜΗΚΟΣ mm	ΣΧΟΙΝΙ mm	BREAK/LOAD kg
34.171	35	94	8	600
34.172	50	120	10	1050
34.173	60	138	12	1200
34.174	70	168	12	2000
34.175	90	225	14	3200



ΡΑΟΥΛΟ ΤΡΙΠΛΟ ΜΕ ΔΑΓΚΑΝΑ

ΚΩΔΙΚΟΣ	ΤΡΟΧΑΛΙΑ mm	ΜΗΚΟΣ mm	ΣΧΟΙΝΙ mm	BREAK/LOAD kg
34.201	35	94	8	600
34.202	50	120	10	1050
34.203	60	138	12	1200
34.204	70	168	12	2000
34.205	90	225	14	3200



ΡΑΟΥΛΟ ΤΡΙΠΛΟ ΣΤΡΙΦΤΑΡΙ

ΚΩΔΙΚΟΣ	ΤΡΟΧΑΛΙΑ mm	ΜΗΚΟΣ mm	ΣΧΟΙΝΙ mm	BREAK/LOAD kg
34.191	35	94	8	600
34.192	50	120	10	1050
34.193	60	138	12	1200
34.194	70	168	12	2000
34.195	90	225	14	3200



ΡΑΟΥΛΟ ΜΟΝΟ

ΚΩΔΙΚΟΣ	ΤΡΟΧΑΛΙΑ mm	ΜΗΚΟΣ mm	ΣΧΟΙΝΙ mm	BREAK/LOAD kg
34.181	22	38	6	390



ΔΑΓΚΑΝΑ

34.401 ΜΙΚΡΗ 3-6mm

34.402 ΜΕΓΑΛΗ 3-12mm



ΟΔΗΓΟΣ ΔΑΓΚΑΝΑΣ ANGLE ΓΩΝΙΑ

34.403 ΜΙΚΡΟ

34.404 ΜΕΓΑΛΟ



ΟΔΗΓΟΣ ΔΑΓΚΑΝΑΣ

34.405 ΜΙΚΡΟ

34.406 ΜΕΓΑΛΟ

ΜΠΑΛΟΝΙΑ A SERIES

ΛΕΥΚΟ Α	ΜΑΥΡΟ Β	ΠΟΡΤΟΚΑΛΙ	ΓΚΡΙ	A SERIES	ΔΙΑΜ. cm	ΜΗΚΟΣ cm	ΠΛΕΥΣΤ/ΤΑ kg
18.430A	18.430B			A-0	20	27	6
18.431A	18.431B			A-1	29	41	15
18.432A	18.432B	18.036		A-2	34	49	31
18.433A	18.433B	18.046		A-3	46	57	56
18.434A	18.434B	18.056		A-4	53	64	90
18.435A	18.435B	18.066		A-5	62	80	160
18.436A	18.436B		18.515	A-6	85	100	326



ΜΠΑΛΟΝΙΑ G SERIES

ΛΕΥΚΟ	ΜΑΥΡΟ	G-SERIES	ΔΙΑΜ.cm	ΜΗΚΟΣcm
18.421A	18.421B	G1	9.0	33.0
18.422A	18.422B	G2	11.5	41.0
18.423A	18.423B	G3	14.0	51.0
18.424A	18.424B	G4	16.5	58.5
18.425A	18.425B	G5	21.6	70.0



ΜΠΑΛΟΝΙΑ F SERIES / ΜΑΥΡΑ ΑΚΡΑ

ΛΕΥΚΟ	ΛΕΥΚΟ ΜΑΥΡΟ	ΜΑΥΡΟ Β	F SERIES	ΔΙΑΜ. cm	ΜΗΚΟΣ cm	ΠΛΕΥΣΤ/ΤΑ kg
18.301A		18.301B	F-0	11,5	42	3,0
18.303A		18.303B	F-1	15	61	8,0
18.304A		18.304B	F-02	18	61	10
	18.305A	18.305B	F-2	22	62	13
	18.306A	18.306B	F-3	22	75	20
	18.310A	18.310B	F-4	22	106	65
	18.307A	18.307B	F-5	30	77	45
	18.308A	18.308B	F-6	27	100	65
	18.309A	-	F-7	38	125	120





ΜΠΑΛΟΝΙΑ ΗΤΜ SERIES ΜΕ ΣΧΟΙΝΙ

ΛΕΥΚΟ	ΜΠΛΕ	ΜΑΥΡΟ	ΗΤΜ SERIES	ΔΙΑΜ cm	ΜΗΚΟΣcm
18.401-A	18.401-B	18.401-C	ΗΤΜ-1	15	40
18.402-A	18.402-B	18.402-C	ΗΤΜ-2	20	52
18.403-A	18.403-B	18.403-C	ΗΤΜ-3	25	70
18.404-A	18.404-B	18.404-C	ΗΤΜ-4	30	95



ΜΠΑΛΟΝΙ ΝFD

ΛΕΥΚΟ A	ΜΑΥΡΟ B	ΔΙΑΜ. cm	ΜΗΚΟΣ cm	ΠΛΕΥΣΤ. kg	NFD SER
18.440A	18.440B	18	51	10	NFD1
18.441A	18.441B	22	60	15	NFD2
18.442A	18.442B	26	71	23	NFD3



ΜΠΑΛΟΝΙΑ JP SERIES

ΛΕΥΚΟ	ΜΑΥΡΟ	JP-SERIES	ΔΙΑΜ cm	ΜΗΚΟΣcm
18.411A	18.411B	JP1	13	41
18.412A	18.412B	JP2	18	61
18.413A	18.413B	JP3	25	83



ΣΗΜΑΔΟΥΡΑ ΜΠΑΛΟΝΙ ΜΕ ΣΙΔΕΡΟ/ΠΟΡΤΟΚΑΛΙ

ΚΩΔΙΚΟΣ	ΔΙΑΜ cm	ΜΗΚΟΣcm	ΠΛΕΥΣΤΟΤΗΤΑ kg
18.202	43	87	27
18.203	52	90	55
18.204	60	92	100



ΣΧΟΙΝΙ ΜΠΑΛΟΝΙΟΥ FLAT ΓΙΑ ΓΑΣ

- 11.765 ΜΠΛΕ 10mm
- 11.766 ΜΑΥΡΟ 10mm



ΣΧΟΙΝΙ ΜΠΑΛΟΝΙΩΝ ΜΕ ΓΑΣ

ΚΩΔΙΚΟΣ	ΧΡΩΜΑ	ΔΙΑΜ.	ΜΗΚΟΣ
11.757	ΜΠΛΕ	6mm	1.5m
11.758	ΜΑΥΡΟ	6mm	1.5 m
11.759	ΜΑΥΡΟ	8mm	1.5m
11.760	ΜΠΛΕ	8mm	1.5m
11.761	ΜΑΥΡΟ	10mm	2.0m
11.731	ΜΠΛΕ	10mm	2.0m
11.762	ΜΑΥΡΟ	12mm	3.0m
11.763	ΜΠΛΕ	12mm	3.0m





ΚΑΛΥΜΑΤΑ ΜΠΑΛΟΝΙΩΝ



ΚΑΛΥΜΑΤΑ ΜΠΑΛΟΝΙΩΝ

ΜΠΛΕ	ΜΑΥΡΟ	ΓΚΡΙ	ΑΝΘΡΑΚΙ	ΜΠΑΛΟΝΙ	ΔΙΑΣΤ. cm
18.012	18.112	18.211		F0/G2	15x40
18.010	18.111	18.212		F01/G3	15x56
18.013	18.113	18.213		F1/G4	15x61
18.014	18.114	18.214		F02	20x66
18.015	18.115	18.215	18.815	F2/G5	21x63
18.016	18.116	18.216	18.816	F3	23x76
18.001	18.121	18.221		F4	23x104
18.017	18.117	18.217	18.817	F5/HTM3/G6	30x76
18.018	18.118			LARGE	30x90
18.019	18.119	18.219	18.819	F6	30x107
18.020	18.120	18.220		F7/HTM4	38x104
18.029	18.129			F8	38x140
18.030	18.130			F10	50x127

ΜΠΛΕ	ΜΑΥΡΟ	ΓΚΡΙ	ΑΝΘΡΑΚΙ	ΜΠΑΛΟΝΙ	ΔΙΑΣΤ. cm
18.028	18.128			A1	29x41
18.023	18.123	18.223	18.823	A2	39x49
18.024	18.124	18.224	18.824	A3	47x59
18.025	18.125	18.225	18.825	A4	55x71
18.026	18.126	18.226	18.826	A5	70x92
18.027	18.127	18.227		A6	86x118



ΜΠΑΛΟΝΙ ΠΛΩΡΗΣ ΜΟΥΣΤΑΚΙ

ΛΕΥΚΟ	ΜΑΥΡΟ	ΥΨΟΣ cm	ΜΗΚΟΣ cm
18.021A	18.021B	10,5	85,5
18.022A	18.022B	14	129,5



18.451

ΜΠΑΛΟΝΙ ΝΤΟΚΟΥ 27x89cm



18.452

ΜΠΑΛΟΝΙ ΝΤΟΚΟΥ 27x89cm



99.758

ΜΠΑΛΟΝΟΘΗΚΗ ΔΙΠΛΗ ΓΙΑ ΡΕΛΙ
Φ19mm F1-F2-G4



ΜΠΑΛΟΝΟΘΗΚΗ ΙΝΟΧ

99.749	Φ170x405mm	F1-HTM1/G3
99.750	Φ195x433mm	F02/G4
99.754	Φ215x440mm	F2
99.751	Φ230x433mm	F2/G5
99.752	Φ260x550mm	F3



93.105

ΕΝΩΤΙΚΟ ΜΠΑΛΟΝΟΘΗΚΗΣ



93.104

ΒΑΣΗ ΜΠΑΛΟΝΟΘΗΚΗΣ
ΓΙΑ ΡΕΛΙΑ ΛΕΥΚΗ

ΜΠΑΛΟΝΙ ΦΟΥΣΚΩΤΟ PVC

ΚΩΔ.	ΜΗΚΟΣ cm	ΔΙΑΜ. cm	ΧΡΩΜΑ
18.002	70	30	ΓΚΡΙ
18.003	110	30	ΓΚΡΙ
18.004	100	45	ΓΚΡΙ
18.005	170	45	ΓΚΡΙ
18.006	182	60	ΓΚΡΙ

ΚΑΛΥΜΑΤΑ ΜΠΑΛΟΝΙΩΝ ΕΛΑΣΤΙΚΑ (ΝΕΟΠΡΕΝ)

ΜΠΛΕ	ΜΑΥΡΟ	ΓΚΡΙ	ΜΠΑΛΟΝΙ	ΔΙΑΣΤΑΣΗ
18.601A	18.601B	18.601C	F-1	15X60
18.602A	18.602B	18.602C	F-2	21X63
18.603A	18.603B	18.603C	F-3	23X76
18.604A	18.604B	18.604C	F-4	23X104
18.605A	18.605B	18.605C	F-5	30X76
18.606A	18.606B	18.606C	F-6	30X107
18.607A	18.607B	18.607C	F-7	38X125
18.445A	18.445B	18.445C	NFD-1	18X51
18.446A	18.446B	18.446C	NFD-2	22X60
18.447A	18.447B	18.447C	NFD-3	26X71
18.703A	18.703B	18.703C	A-3	47X59
18.704A	18.704B	18.704C	A-4	55X71
18.705A	18.705B	18.705C	A-5	70X92
18.706A	18.706B	18.706C	A-6	86X118





ΚΩΝΙΚΗ ΣΗΜΑΔΟΥΡΑ ΜΕ ΠΟΛΥΟΥΡΕΘΑΝΗ ΚΑΙ ΙΝΟΧ ΣΙΔΕΡΟ

ΚΩΔΙΚΟΣ	ΔΙΑΜ. mm	ΥΨΟΣ mm	ΛΙΤΡΑ	ΠΛΕΥΣΤΟΤΗΤΑ kg	ΒΑΡΟΣ kg
20.001	320	800	15	25	3.8
20.002	500	1030	55	50	8.7



ΚΩΝΙΚΕΣ ΣΗΜΑΔΟΥΡΕΣ

ΚΩΔΙΚΟΣ		ΔΙΑΜ. mm	ΥΨΟΣ mm	ΛΙΤΡΑ	ΠΛΕΥΣΤΟΤΗΤΑ kg
ΚΟΚΚΙΝΕΣ	ΚΙΤΡΙΝΕΣ				
20.011	20.012	220	490	5	8
20.013	20.014	270	600	9	13
20.015	20.016	320	800	15	25
20.017	20.018	500	1030	55	55



ΦΑΝΟΣ ΚΩΝΙΚΗΣ LED
ΑΝΑΛΑΜΠΩΝ

- 14.222 ΚΙΤΡΙΝΟΣ
- 14.226 ΛΕΥΚΟΣ
- 14.227 ΚΟΚΚΙΝΟΣ

98.160
ΤΕΦΛΟΝ
ΦΑΝΟΥ ΚΩΝΙΚΗΣ

ΚΩΝΙΚΗ 15Lt ΜΕ ΦΑΝΟ LED

ΚΩΔΙΚΟΣ	ΦΑΝΟΣ LED	ΔΙΑΜ.	ΥΨΟΣ	ΛΙΤΡΑ	ΠΛΕΥΣΤΟΤΗΤΑ kg
20.004A	ΛΕΥΚΟΣ	320	800	15	20
20.004B	ΚΟΚΚΙΝΟΣ	320	800	15	20
20.004C	ΚΙΤΡΙΝΟΣ	320	800	15	20



Φ25cm x H39cm

- 20.956 - ΣΗΜΑΔΟΥΡΑ ΑΧΛΑΔΙ ΚΟΚΚΙΝΗ
- 20.957 - ΣΗΜΑΔΟΥΡΑ ΑΧΛΑΔΙ ΚΙΤΡΙΝΗ
- 20.955 - ΣΗΜΑΔΟΥΡΑ ΑΧΛΑΔΙ ΛΕΥΚΗ



Φ15cm x H20cm

- 20.020 - ΚΑΛΑΔΟΥΡΙ ΣΤΡΟΓΓΥΛΟ ΚΙΤΡΙΝΟ
- 20.021 - ΚΑΛΑΔΟΥΡΙ ΣΤΡΟΓΓΥΛΟ ΚΟΚΚΙΝΟ
- 20.034 - ΚΑΛΑΔΟΥΡΙ ΣΤΡΟΓΓΥΛΟ ΛΕΥΚΟ



Φ13cm x 39cm

20.022
ΚΑΛΑΔΟΥΡΙ
ΜΙΚΡΟ ΚΟΚΚΙΝΟ



20.019
ΚΑΛΑΔΟΥΡΙ
ΜΙΚΡΟ ΚΙΤΡΙΝΟ



Φ20cm x 47cm

20.959
ΚΑΛΑΔΟΥΡΙ ΜΕΓΑΛΟ
ΚΟΚΚΙΝΟ



20.023
ΚΑΛΑΔΟΥΡΙ ΜΕΓΑΛΟ
ΚΙΤΡΙΝΟ



20.024 - ΦΕΛΛΟΣ ΠΛΑΣΤΙΚΟΣ Φ 26 cm ΜΕΓΑΛΟΣ -ΠΟΡΤΟΚΑΛΙ

20.025 - ΦΕΛΛΟΣ ΠΛΑΣΤΙΚΟΣ Φ 26 cm ΜΕΓΑΛΟΣ -ΚΙΤΡΙΝΟ

20.026 - ΦΕΛΛΟΣ ΠΛΑΣΤΙΚΟΣ Φ 26 cm ΜΕΓΑΛΟΣ -ΛΕΥΚΟ



20.027 - ΦΕΛΛΟΣ ΠΛΑΣΤΙΚΟΣ Φ 17 cm ΜΕΣΑΙΟΣ -ΠΟΡΤΟΚΑΛΙ

20.028 - ΦΕΛΛΟΣ ΠΛΑΣΤΙΚΟΣ Φ 17 cm ΜΕΣΑΙΟΣ -ΚΙΤΡΙΝΟ

20.029 - ΦΕΛΛΟΣ ΠΛΑΣΤΙΚΟΣ Φ 17 cm ΜΕΣΑΙΟΣ -ΛΕΥΚΟ



20.030 - ΦΕΛΛΟΣ ΠΛΑΣΤΙΚΟΣ Φ 8 cm -ΠΟΡΤΟΚΑΛΙ

20.032 - ΦΕΛΛΟΣ ΠΛΑΣΤΙΚΟΣ Φ 8 cm -ΚΙΤΡΙΝΟ

20.033 - ΦΕΛΛΟΣ ΠΛΑΣΤΙΚΟΣ Φ 8 cm -ΛΕΥΚΟ



25.045

ΛΥΧΝΙΑ ΑΥΤΟΜΑΤΗ ΜΕ
ΚΟΚΚΙΝΟ LED ΑΝΑΛΑΜΠΩΝ
ΕΠΙΠΛΕΟΥΣΑ



24.021

ΒΑΘΥΣΚΟΠΙΟ



25.011 - ΛΥΧΝΙΑ ΑΥΤΟΜΑΤΗ 1 ΜΠΑΤΑΡΙΑ LED



25.043 - ΛΥΧΝΙΑ ΑΥΤΟΜΑΤΗ ΜΕ ΛΕΥΚΟ ΑΝΑΛΑΜΠΩΝ LED 2 ΜΠΑΤΑΡΙΕΣ

25.046 - ΛΥΧΝΙΑ ΑΥΤΟΜΑΤΗ ΜΕ ΚΟΚΚΙΝΟ ΑΝΑΛΑΜΠΩΝ LED 2 ΜΠΑΤΑΡΙΕΣ



24.011

ΣΗΜΑΔΟΥΡΑ ΔΥΤΗ ΜΕΓΑΛΗ



24.012

ΣΗΜΑΔΟΥΡΑ ΔΥΤΗ ΜΙΚΡΗ



99.724

ΣΧΟΙΝΙ ΑΦΡΟΥ 3mm
ΓΙΑ ΣΗΜΑΔΟΥΡΑ ΔΥΤΗ



21.111

ΖΩΝΗ ΥΠΟΒΡΥΧΙΟΥ
ΨΑΡΕΜΑΤΟΣ



10.610
ΚΟΝΕΚΤΟΡΑΣ ΘΗΛΥΚΟ
YAM-MER-MAR



10.605
ΚΟΝΕΚΤΟΡΑΣ ΘΗΛΥΚΟ
OMC



10.627
ΚΟΝΕΚΤΟΡΑΣ ΘΗΛΥΚΟ
HONDA C14506



10.608
ΚΟΝΕΚΤΟΡΑΣ ΑΡΣΕΝΙΚΟ
YAMAHA ΜΕ ΣΠΕΙΡΩΜΑ



10.603
ΚΟΝΕΚΤΟΡΑΣ ΑΡΣΕΝ.
OMC ΜΕ ΣΠΕΙΡΩΜΑ



10.624
ΚΟΝΕΚΤΟΡΑΣ SILVER
ΘΗΛΥΚΟ OMC



10.625
ΚΟΝΕΚΤΟΡΑΣ SILVER
ΘΗΛΥΚΟ YAM/MERC



10.626
ΚΟΝΕΚΤΟΡΑΣ SILVER
ΘΗΛΥΚΟ MERCURY



10.629
ΚΟΝΕΚΤΟΡΑΣ SILVER
ΘΗΛΥΚΟ HONDA



10.616
ΚΟΝΕΚΤΟΡΑΣ ΘΗΛΥΚΟ
MERCURY-MARINER



10.617
ΚΟΝΕΚΤΟΡΑΣ ΑΡΣΕΝΙΚΟ
MERCURY-MARINER



10.606
ΚΟΝΕΚΤΟΡΑΣ ΑΡΣΕΝΙΚΟ
YAMAHA ΓΙΑ ΣΩΛΗΝΑ



10.601
ΚΟΝΕΚΤΟΡΑΣ ΑΡΣΕΝΙΚΟ
OMC ΓΙΑ ΣΩΛΗΝΑ



10.630
ΚΟΝΕΚΤΟΡ ΣΥΝΔ.
ΓΙΑ ΔΥΟ ΜΗΧΑΝΕΣ



10.609
ΚΟΝΕΚΤΟΡΑΣ
ΑΡΣΕΝΙΚΟ YAMAHA-
MERCURY-MARINER
ΜΗΧΑΝΗΣ



10.604
ΚΟΝΕΚΤΟΡΑΣ
ΑΡΣΕΝΙΚΟ OMC
ΓΙΑ ΜΗΧΑΝΗ



10.614 INOX
ΚΟΝΕΚΤΟΡΑΣ
ΘΗΛΥΚΟ ΚΟΝΕΚΤΟΡ
HONDA 3/8 ΣΩΛΗΝΑ



10.618 INOX
ΚΟΝΕΚΤΟΡΑΣ ΘΗΛΥΚΟ
TOHATSU ΓΙΑ ΣΩΛΗΝΑ
ΜΗΧΑΝΗΣ T14504T



10.619 INOX
ΚΟΝΕΚΤΟΡΑΣ
ΑΡΣΕΝΙΚΟ TOHATSU
ΜΕ ΑΚΡΟ



10.620 INOX
ΚΟΝΕΚΤΟΡΑΣ ΘΗΛΥΚΟ
SUZUKI-CHRYSLER-
FORCE ΓΙΑ ΣΩΛΗΝΑ
ΜΗΧΑΝΗΣ



10.621 INOX
ΚΟΝΕΚΤΟΡΑΣ
ΑΡΣΕΝΙΚΟ SUZUKI
ΜΕ ΣΠΕΙΡΩΜΑ



10.615 INOX
ΚΟΝΕΚΤΟΡΑΣ
ΑΡΣΕΝΙΚΟ HONDA
1/4" NPT



10.622 INOX
ΚΟΝΕΚΤΟΡΑΣ ΘΗΛΥΚΟ
SUZUKI-TOHATSU ΓΙΑ
ΣΩΛΗΝΑ TANK C14535



10.623 INOX
ΚΟΝΕΚΤΟΡΑΣ
ΑΡΣΕΝΙΚΟ TOHATSU
ΜΕ ΣΠΕΙΡΩΜΑ
T14509T



10.652 - ΠΟΥΑΡ ΒΕΝΖΙΝΗΣ ΜΙΚΡΟ ΕΩΣ 2000cc
10.653 - ΠΟΥΑΡ ΒΕΝΖΙΝΗΣ ΜΕΓΑΛΟ ΕΩΣ 3500cc



ΠΟΥΑΡ ΒΕΝΖΙΝΗΣ (BLISTER)
10.654 ΜΙΚΡΟ 5/16"
10.655 ΜΕΓΑΛΟ 5/16"
10.656 ΜΕΓΑΛΟ 3/8"



10.850 - ΔΙΑΚΟΠΤΗΣ ΒΕΝΖΙΝΗΣ ΤΡΙΩΝ ΘΕΣΕΩΝ 1/4"
10.928 - ΔΙΑΚΟΠΤΗΣ ΒΕΝΖΙΝΗΣ ΤΡΙΩΝ ΘΕΣΕΩΝ 3/8"



ΣΩΛΗΝΑ ΒΕΝΖΙΝΗΣ ΕΝΙΣΧΥΜΕΝΗ
10.663 7mm (-20ο ΕΩΣ +60ο)
10.665 9mm (-20ο ΕΩΣ +60ο)



ΣΩΛΗΝΑΣ ΒΕΝΖΙΝΗΣ ΜΕ ΠΛΕΓΜΑ
10.651 Ø8mm
94.149 Ø10mm



10.959
ΔΙΑΚΟΠΤΗΣ ΒΕΝΖΙΝΗΣ ΔΙΠΛΟΣ 8mm



ΣΩΛΗΝΑ ΒΕΝΖΙΝΗΣ ΜΕ ΠΟΥΑΡ
10.661 3m
10.662 2m



96.423
ΣΩΛΗΝΑ ΒΕΝΖΙΝΗΣ ΜΕ ΜΙΚΡΟ ΠΟΥΑΡ 2m



10.664
ΣΩΛΗΝΑ ΒΕΝΖΙΝΗΣ ΕΝΙΣΧΥΜΕΝΗ ΜΕ ΜΕΓΑΛΟ ΠΟΥΑΡ 5/16" (BLISTER) 2m



10.852
ΗΛΕΚΤΡΟΒΑΝΑ Φ8-10mm 200lt-h



20.521
ΒΕΝΤΟΥΖΑ ΠΛΥΣΙΜΑΤΟΣ ΜΙΚΡΗ ΣΤΡΟΓΓΥΛΗ



20.523
ΒΕΝΤΟΥΖΑ ΠΛΥΣΙΜΑΤΟΣ ΜΗΧΑΝΗΣ ΤΕΤΡΑΓΩΝΗ



20.958
ΒΕΝΤΟΥΖΑ ΠΛΥΣΙΜΑΤΟΣ ΔΙΠΛΗΣ ΕΝΕΡΓΕΙΑΣ (ΕΠΑΓΓΕΛΜΑΤΙΚΗ)



ΛΑΔΙ ΜΙΞΗΣ 2-ΧΡΟΝΗΣ PREMIUM

- 29.001 1Lt
- 29.002 4Lt
- 29.003 10Lt



ΛΑΔΙ ΜΙΞΗΣ 2-ΧΡΟΝΗΣ PREMIUM PLUS

- 29.004 1Lt
- 29.005 4Lt
- 29.006 10Lt



ΒΑΛΒΟΛΙΝΗ ΗΡ

- 29.010 ΣΩΛΗΝΑΡΙΟ 0,24Lt
- 29.008 1Lt
- 29.017 10Lt



ΛΑΔΙ 4-ΧΡΟΝΗΣ

- 29.018 1Lt 10W30
- 29.021 4Lt 10W30
- 29.009 1Lt 25W40
- 29.016 4Lt 25W40
- 29.020 1Lt 25W40 SYNTHETIC
- 29.012 4Lt 25W40 SYNTHETIC
- 29.019 4Lt 25W50 VERADO



29.007

ΛΑΔΙ OPTIMAX DFI 4Lt



29.015

ΓΡΑΣΟ ΘΑΛΑΣΣΗΣ 0,24Lt



ΛΑΔΙ 4-ΧΡΟΝΗΣ

- 29.031 1Lt
- 29.032 4 Lt
- 29.033 10 Lt



ΒΑΛΒΟΛΙΝΗ GL5

- 29.037 1 Lt
- 29.038 20 Lt



ΛΑΔΙ ΜΙΞΗΣ 2-ΧΡΟΝΗΣ

- 29.035 1Lt
- 29.036 4Lt



29.039

**ΛΑΔΙ 4-ΧΡΟΝΗΣ
1lt HONDA MARINE
10W30**



29.011 - ΑΝΤΛΙΑ ΒΑΛΒΟΛΙΝΗΣ



29.013- ΓΡΑΣΑΔΟΡΟΣ ΠΙΣΤΟΛΙ



29.014 - ΓΡΑΣΑΔΟΡΟΣ ΣΥΡΙΓΓΑ



10.253 - ΚΑΝΙΣΤΡΟ 5lt ΕΝΙΣΧΥΜΕΝΟ

10.254 - ΚΑΝΙΣΤΡΟ 10lt ΕΝΙΣΧΥΜΕΝΟ

10.255 - ΚΑΝΙΣΤΡΟ 20lt ΕΝΙΣΧΥΜΕΝΟ



ΚΑΝΙΣΤΡΟ ΜΕΤΑΦΟΡΑΣ

10.211 5 Lt

10.212 10 Lt

10.230 20 Lt



ΚΑΝΙΣΤΡΟ ΕΝΙΣΧΥΜΕΝΟ NT

ALL STAR

10.256 5LT

10.257 10LT

10.258 20LT



10.251

ΡΕΖΕΡΒΟΥΑΡ ΜΕΤΑΦΟΡΑΣ ΚΑΥΣΙΜΟΥ
ΜΕ ΡΟΔΕΣ 59 lt



10.250

ΚΑΝΙΣΤΡΟ ΜΕΤΑΦΟΡΑΣ 20 Lt INOX

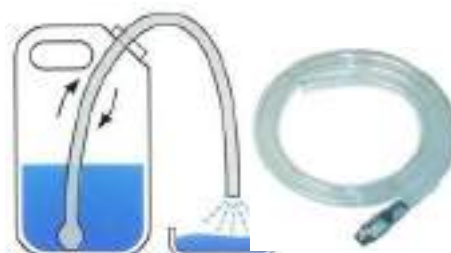

ΑΝΤΛΙΑ ΜΕΤΑΓΓΙΣΗΣ

10.960 ΜΙΚΡΗ 3/4"

10.977 ΜΕΓΑΛΗ 1"



96.101

ΧΩΝΙ ΠΛΑΣΤΙΚΟ
ΜΕΤΑΓΓΙΣΗΣ



96.099

ΧΩΝΙ ΚΑΥΣΙΜΟΥ
RACOR ΜΙΚΡΟ 3.5 GPM



96.100

ΧΩΝΙ ΚΑΥΣΙΜΟΥ RACOR
ΜΕΓΑΛΟ 5 GPM



10.574

ΑΝΤΛΙΑ ΜΕΤΑΓΓΙΣΗΣ ΜΕ ΜΠΑΤΑΡΙΑ
ΛΙΘΙΟΥ-USB



ΡΕΖΕΡΒΟΥΑΡ ALPHA (ORIGINAL)

ΚΩΔ.	ΧΩΡΗΤ. Lt	ΥΨΟΣ mm	ΠΛΑΤΟΣ mm	ΒΑΘΟΣ mm	ΒΑΡΟΣ kg
10.012	12	410	260	190	1,3
10.022	22	550	330	230	2



10.011
10.024
10.031



10.023

ΡΕΖΕΡΒΟΥΑΡ DELTA (ΤΕΤΡΑΓΩΝΟ)

ΚΩΔ.	ΧΩΡΗΤ. Lt	ΥΨΟΣ mm	ΠΛΑΤΟΣ mm	ΒΑΘΟΣ mm	ΒΑΡΟΣ kg
10.011	12	400	280	170	1,4
10.024	24	460	340	230	2,1
10.031	29	510	365	230	2,5
10.023	22	405	330	240	2,0



ΜΕΤΡΗΤΗΣ ΜΗΧΑΝΙΚΟΣ
ΜΕ ΕΞΑΕΡΙΣΤΙΚΟ

- 10.500 16cm
- 10.501 20cm



10.098

ΤΑΠΑ ΡΕΖΕΡΒΟΥΑΡ ΜΕ
ΕΞΑΕΡΙΣΤΙΚΟ ΜΠΛΕ



97.114

ΑΝΤΑΛΛΑΚΤΙΚΟ ΡΟΥΞΟΥΝΙ



96.801

ΡΕΖΕΡΒΟΥΑΡ INOX 45Lt
L60 x W30 x H25cm

96.802

ΡΕΖΕΡΒΟΥΑΡ INOX 63Lt
L90 x W35 x H20cm



ΡΕΖΕΡΒΟΥΑΡ JULLIET

ΚΩΔ.	ΧΩΡΗΤ. Lt	ΜΗΚΟΣ mm	ΥΨΟΣ mm	ΠΛΑΤΟΣ mm	ΒΑΡΟΣ kg	ΜΕΤΡΗΤΗΣ	
						10-1800	240-330
10.062	62	660	410+30	300	7.2	31.039	31.139
10.090	91	910	410+30	300	8.2	31.039	31.139



ΡΕΖΕΡΒΟΥΑΡ KILO

ΚΩΔ.	ΧΩΡΗΤ. Lt	ΜΗΚΟΣ mm	ΥΨΟΣ mm	ΠΛΑΤΟΣ mm	ΒΑΡΟΣ kg	ΜΕΤΡΗΤΗΣ	
						10-1800	240-330
10.063	62	660	300+30	410	7.2	31.028	31.128
10.091	91	910	300+30	410	8.2	31.028	31.128



ΡΕΖΕΡΒΟΥΑΡ ΝΕΟΥ ΤΥΠΟΥ FOX TROT

ΚΩΔ.	ΧΩΡΗΤ. Lt	ΜΗΚΟΣ mm	ΥΨΟΣ mm	ΠΛΑΤΟΣ mm	ΒΑΡΟΣ kg	ΜΕΤΡΗΤΗΣ	
						10-1800	240-330
96.024	28	450	200	390	2,5	31.017	31.117
96.023	35	550	200	390	3,5	31.017	31.117
96.022	41	650	200	390	4,5	31.017	31.117
96.021	48	750	200	390	5,5	31.017	31.117
96.254	54	850	200	390	6,5	31.017	31.117
96.261	61	950	200	390	7,5	31.017	31.117
96.267	67	1050	200	390	8,5	31.017	31.117



96.343	43	450	290	390	3	31.028	31.128
96.353	53	550	290	390	4	31.028	31.128
96.363	63	650	290	390	5	31.028	31.128
96.373	73	750	290	390	6	31.028	31.128
96.183	83	850	290	390	7	31.028	31.128
96.193	93	950	290	390	8	31.028	31.128
96.103	103	1050	290	390	9	31.028	31.128

ΡΕΖΕΡΒΟΥΑΡ GOLF ΜΕ ΧΕΙΡΟΛΑΒΗ



ΚΩΔ.	ΧΩΡΗΤ. Lt	ΜΗΚΟΣ mm	ΥΨΟΣ mm	ΠΛΑΤΟΣ mm	ΒΑΡΟΣ kg	ΜΕΤΡΗΤΗΣ	
						10-180Ω	240-33Ω
10.906	40	500	280	400	4	31.025	31.125
10.907	50	650	280	400	5	31.025	31.125
10.908	65	800	280	400	6	31.025	31.125

ΡΕΖΕΡΒΟΥΑΡ HOTEL



ΚΩΔ.	ΧΩΡΗΤ. Lt	ΜΗΚΟΣ mm	ΥΨΟΣ mm	ΠΛΑΤΟΣ mm	ΒΑΡΟΣ kg	ΜΕΤΡΗΤΗΣ	
						10-180Ω	240-33Ω
10.909	70	800	280	400	6,5	31.025	31.125
10.910	84	950	280	400	7	31.025	31.125
10.911	96	1100	280	400	7,7	31.025	31.125
96.010	102	800	400	400	6,5	31.039	31.139
96.011	120	950	400	400	7,3	31.039	31.139
96.012	140	1100	400	400	8,2	31.039	31.139

ΡΕΖΕΡΒΟΥΑΡ INDIA



ΚΩΔ.	ΧΩΡΗΤ. Lt	ΜΗΚΟΣ mm	ΥΨΟΣ mm	ΠΛΑΤΟΣ mm	ΒΑΡΟΣ kg	ΜΕΤΡΗΤΗΣ	
						10-180Ω	240-33Ω
10.033	33	500	230	350	3	31.020	31.120
10.043	43	650	230	350	4,3	31.020	31.120
10.053	53	800	230	350	5,4	31.020	31.120
10.042	42	500	300	350	3,1	31.028	31.128
10.055	55	650	300	350	5,3	31.028	31.128
10.070	70	800	300	350	6,4	31.028	31.128

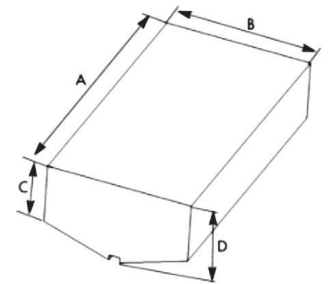

ΡΕΖΕΡΒΟΥΑΡ ΜΕ "V"

ΚΩΔ.	ΧΩΡΗΤ. Lt	A mm	B mm	C mm	D mm	ΜΕΤΡΗΤΗΣ	
						10-180Ω	240-33Ω
96.532	57	600	500	150	230	31.022	31.122
96.531	86	1070	500	150	230	31.022	31.122
96.530	130	1220	520	180	265	31.025	31.125



ΚΩΔ.	Capacity lt	A mm	B mm	C mm	D mm	ΜΕΤΡΗΤΗΣ 240/30 Ω
96.535	210	1240	580	300	340	31.130
96.540	96	650	580	300	270	31.125



ΚΩΔ.	Capacity lt	A mm	B mm	D mm	ΜΕΤΡΗΤΗΣ 10/180 Ω	ΜΕΤΡΗΤΗΣ 240/30 Ω
96.536	128	850	650	270+47	31.025	31.125



ΚΩΔ.	Capacity lt	A mm	B mm	C mm	D mm	ΜΕΤΡΗΤΗΣ 10/180 Ω	ΜΕΤΡΗΤΗΣ 240/30 Ω
96.537	356	1280	940	280	270+47	31.039	31.139



ΚΩΔ.	Capacity lt	A mm	B mm	C mm	D mm	ΜΕΤΡΗΤΗΣ 10/180 Ω	ΜΕΤΡΗΤΗΣ 240/30 Ω
96.539	250	1200	940	190	370+72	31.035	31.135



32.102
ΡΟΥΞΟΥΝΙ ΣΩΛΗΝΑ
ΠΛΑΣΤΙΚΟ ΣΠΕΙΡΩΜΑ
3/8" Φ10-12mm



32.103
ΡΟΥΞΟΥΝΙ ΣΩΛΗΝΑ
ΠΛΑΣΤΙΚΟ ΣΠΕΙΡΩΜΑ
1/4" Φ10mm



32.104
ΡΟΥΞΟΥΝΙ ΣΩΛΗΝΑ
ΠΛΑΣΤΙΚΟ ΣΠΕΙΡΩΜΑ
3/8" Φ16mm



32.105
ΡΟΥΞΟΥΝΙ ΣΩΛΗΝΑ ΓΩΝΙΑΚΟ
ΠΛΑΣΤΙΚΟ ΣΠΕΙΡΩΜΑ
3/8" 12mm



ΣΩΛΗΝΑΣ ΚΑΥΣΑΕΡΙΩΝ
94.161 Φ45mm
94.162 Φ51mm
94.164 Φ75mm



ΣΩΛΗΝΑΣ ΚΑΥΣΙΜΟΥ CE
94.150 12mm
94.151 16mm
94.152 19mm
94.153 25mm
94.154 38mm
94.155 50mm



10.504
ΒΑΣΕΙΣ ΣΤΗΡΙΞΗΣ
ΡΕΖΕΡΒΟΥΑΡ-ΣΧΕΔΙΑΣ



10.099
ΤΑΠΑ ΡΕΖΕΡΒΟΥΑΡ ΜΕ
ΕΞΑΕΡΙΣΤΙΚΟ-ΚΟΚΚΙΝΗ



10.505
ΦΛΑΤΖΑ ΡΕΖΕΡΒΟΥΑΡ
ΒΕΝΖΙΝΗΣ-ΠΕΤΡΕΛΑΙΟΥ



ΓΩΝΙΑ ΠΑΡΟΧΗΣ
ΝΕΡΟΥ-ΚΑΥΣΙΜΟΥ
95.904 Φ38mm
95.907 Φ25mm



95.903
ΡΑΚΟΡ ΙΣΙΟ Φ38mm ΠΑΡΟΧΗΣ
ΡΕΖΕΡΒΟΥΑΡ



10.506
ΓΩΝΙΑ ΠΑΡΟΧΗΣ ΚΑΥΣΙΜΟΥ
Φ38-Φ50mm



32.110
ΤΑΠΑ ΡΕΖΕΡΒΟΥΑΡ
ΜΕΤΑΛΛΙΚΗ ΣΠΕΙΡΩΜΑ
1/4"



32.101
ΤΑΠΑ ΡΕΖΕΡΒΟΥΑΡ
ΠΛΑΣΤΙΚΗ ΣΠΕΙΡΩΜΑ
3/8"



32.118
ΤΑΠΑ ΡΕΖΕΡΒΟΥΑΡ
ΜΕΤΑΛΛΙΚΗ ΣΠΕΙΡΩΜΑ
3/8"



32.111 - ΡΟΥΞΟΥΝΙ ΣΩΛΗΝΑ ΣΠΕΙΡΩΜΑ 1/4" Φ10mm

32.112 - ΡΟΥΞΟΥΝΙ ΣΩΛΗΝΑ ΣΠΕΙΡΩΜΑ 1/4" Φ12mm



32.113 - ΡΟΥΞΟΥΝΙ ΣΩΛΗΝΑ ΣΠΕΙΡΩΜΑ 3/8" Φ12mm

32.114 - ΡΟΥΞΟΥΝΙ ΣΩΛΗΝΑ ΣΠΕΙΡΩΜΑ 3/8" Φ17mm



32.115 - ΡΟΥΞΟΥΝΙ ΦΙΣ ΣΠΕΙΡΩΜΑ 1/4" Φ8mm

32.116 - ΡΑΚΟΡ ΦΙΣ ΣΠΕΙΡΩΜΑ 1/4" Φ10mm



32.117 - ΡΟΥΞΟΥΝΙ ΓΩΝΙΑ ΣΠΕΙΡΩΜΑ ΑΡΣΕΝΙΚΟ 1/4" ΘΗΛΥΚΟ 1/4"



15.515 ΜΕΤΡΗΤΗΣ ΜΗΧΑΝΙΚΟΣ ΡΕΖΕΡΒΟΥΑΡ

ΚΩΔΙΚΟΣ	ΜΗΚΟΣ cm
A	17,5
B	22
C	26,5
D	28,5

ΕΞΑΕΡΙΣΤΙΚΑ

ΕΞΟΠΛΙΣΜΟΣ ΚΙΝΗΤΗΡΩΝ



ΕΞΑΕΡΙΣΤΙΚΟ ΙΝΟΧ ΙΣΙΟ ΧΩΝΕΥΤΟ

10.693 Φ16mm

10.650 Φ19mm



ΕΞΑΕΡΙΣΤΙΚΟ ΙΝΟΧ ΓΩΝΙΑΚΟ

10.694 Φ16mm

10.647 Φ19mm



ΕΞΑΕΡΙΣΤΙΚΟ ΙΝΟΧ ΙΣΙΟ

10.696 Φ16mm

10.648 Φ19mm



10.646

ΕΞΑΕΡΙΣΤΙΚΟ ΠΛΑΣΤΙΚΟ ΓΩΝΙΑΚΟ Φ25mm



10.697

ΕΞΑΕΡΙΣΤΙΚΟ ΠΛΑΣΤΙΚΟ ΓΩΝΙΑΚΟ Φ16/19mm



10.698

ΕΞΑΕΡΙΣΤΙΚΟ ΠΛΑΣΤΙΚΟ ΙΣΙΟ ΛΕΥΚΟ Φ16/19mm



ΕΞΑΕΡΙΣΤΙΚΟ ΙΝΟΧ ΓΩΝΙΑΚΟ ΧΩΝΕΥΤΟ

10.699 Φ16mm

10.649 Φ19mm

ΤΑΠΕΣ ΠΛΗΡΩΣΗΣ ΝΕΡΟΥ, ΚΑΥΣΙΜΩΝ & ΑΚΑΘΑΡΤΩΝ



ΙΝΟΧ ΜΕ ΚΛΕΙΔΙ

ΚΩΔ.	ΔΙΑΜ. mm	ΠΛΑΣΤΙΚΗ
10.706	38	ΚΑΥΣΙΜΟ
10.704	38	ΝΕΡΟ
10.703	50	ΚΑΥΣΙΜΟ
10.707	50	ΝΕΡΟ



ΙΝΟΧ ΜΕ ΚΛΕΙΔΙ

ΚΩΔ.	ΔΙΑΜ. mm	ΙΝΟΧ SS316
10.735	38	ΚΑΥΣΙΜΟ
10.736	50	ΚΑΥΣΙΜΟ
10.737	38	ΝΕΡΟ



ΤΑΠΑ ΠΛΑΣΤΙΚΗ

ΚΩΔ.	ΔΙΑΜ. mm	ΠΛΑΣΤΙΚΗ
10.727	38	ΚΑΥΣΙΜΟ
10.726	38	ΝΕΡΟ



ΙΝΟΧ 38mm ΜΕ ΕΞΑΕΡΙΣΤΙΚΟ

ΚΩΔ.	ΔΙΑΜ. mm	ΠΛΑΣΤΙΚΗ
90.036	38	ΚΑΥΣΙΜΟ
99.735	38	ΝΕΡΟ



ΙΝΟΧ ΓΩΝΙΑΚΗ 30°

ΚΩΔ.	ΔΙΑΜ. mm	ΠΛΑΣΤΙΚΗ
10.700	38	ΚΑΥΣΙΜΟ
10.710	38	ΝΕΡΟ



ΤΑΠΑ ΙΝΟΧ ΚΑΥΣΙΜΟΥ

ΚΩΔ.	ΔΙΑΜ. mm	ΙΝΟΧ SS316
10.718	38	ΚΑΥΣΙΜΟ
10.719	38	ΝΕΡΟ



ΜΕ ΕΞΑΕΡΙΣΤΙΚΟ

ΚΩΔ.	ΔΙΑΜ. mm	ΠΛΑΣΤΙΚΗ	ΧΡΩΜΑ
91.006	38	ΚΑΥΣΙΜΟ	ΧΡΩΜΕ
91.008	50	ΚΑΥΣΙΜΟ	ΧΡΩΜΕ
10.705	38	ΝΕΡΟΥ	ΛΕΥΚΟ
10.503	50	ΝΕΡΟΥ	ΛΕΥΚΟ
10.717	38	ΝΕΡΟΥ	ΧΡΩΜΕ

ΚΩΔ.	ΔΙΑΜ. mm	ΠΛΑΣΤΙΚΗ	ΧΡΩΜΑ
91.010	38	ΚΑΥΣΙΜΟ	ΛΕΥΚΟ
91.008	38	ΚΑΥΣΙΜΟ	ΛΕΥΚΟ
91.009	50	ΚΑΥΣΙΜΟ	ΛΕΥΚΟ



10.720
ΚΛΕΙΔΙ ΓΕΝΙΚΗΣ
ΧΡΗΣΗΣ ΤΑΠΩΝ



ΙΝΟΧ ΠΛΑΚΕ

ΚΩΔ.	ΔΙΑΜ. mm	ΙΝΟΧ SS316
10.709	38	ΚΑΥΣΙΜΟ
10.702	38	ΝΕΡΟ
10.715	38	ΑΚΑΘΑΡΤΩΝ
10.701	50	ΚΑΥΣΙΜΟ
10.708	50	ΝΕΡΟ
10.716	50	ΑΚΑΘΑΡΤΩΝ



ΙΝΟΧ ΜΕ ΚΛΕΙΔΙ

ΚΩΔ.	ΔΙΑΜ. mm	ΠΛΑΣΤΙΚΗ
10.728	38	ΚΑΥΣΙΜΟ
10.738	38	ΝΕΡΟ
10.729	50	ΚΑΥΣΙΜΟ
10.739	50	ΝΕΡΟ



ΙΝΟΧ ΜΕ ΕΞΑΕΡΙΣΤΙΚΟ

ΚΩΔ.	ΔΙΑΜ. mm	ΙΝΟΧ SS316
90.037	38	ΚΑΥΣΙΜΟ
99.734	38	ΝΕΡΟ



ΣΙΛΑΝΣΙΕ ΙΣΙΟ (MUFFLER)

ΚΩΔ.	ΔΙΑΜ. mm	ΜΗΚΟΣ mm	ΠΛΑΤΟΣ mm
10.069	40	372	150
10.071	45	372	150
10.072	50	372	150
10.073	60	372	150
10.074	75	372	150
10.077	90	460	183
10.078	102	460	183



ΣΙΛΑΝΣΙΕ/ΣΙΓΑΣΤΗΡΕΣ (WATERLOCK)

ΚΩΔ.	ΠΕΡΙΓΡΑΦΗ	ΔΙΑΜΕΤΡΟΣ mm	ΜΗΚΟΣ mm	ΥΨΟΣ mm
10.810	ΣΙΛΑΝΣΙΕ 7 Lt	40,5/45,5/50,5	485	220
10.066	ΣΙΛΑΝΣΙΕ 20 Lt	55/60/65	660	320
10.067	ΣΙΛΑΝΣΙΕ 33 Lt	75/90	760	400
10.068	ΣΙΛΑΝΣΙΕ 33 Lt	100/115	760	400

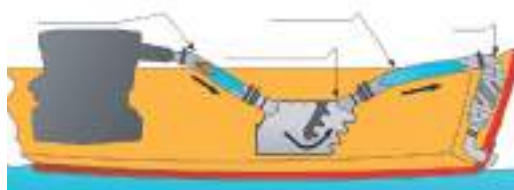

Σχέδιο Εξάτμισης



10.075 - ΣΙΦΩΝΙ ΕΞΑΤΜΙΣΗΣ ΜΕ ΚΑΜΠΥΛΗ

10.076 - ΣΙΦΩΝΙ ΕΞΑΤΜΙΣΗΣ ΙΣΙΟ



99.753

ΑΚΡΟ ΕΞΑΤΜΙΣΗΣ Φ40/45/50



ΣΩΛΗΝΑΣ ΚΑΥΣΑΕΡΙΩΝ

94.161 Φ45mm

94.162 Φ51mm

94.164 Φ75mm



95.068 - ΔΙΑΧΩΡΙΣΤΗΣ ΝΕΡΟΥ-ΒΕΝΖΙΝΗΣ 2,5 Lt

95.089 - ΔΙΑΧΩΡΙΣΤΗΣ ΝΕΡΟΥ-ΒΕΝΖΙΝΗΣ 4,5 Lt



95.074

ΚΟΝΕΚΤΟΡΑΣ ΕΝΩΣΗΣ

13 έως 38 mm



95.075

ΚΟΝΕΚΤΟΡΑΣ ΕΝΩΣΗΣ

32 έως 60 mm



10.671
ΦΙΛΤΡΟ ΠΕΤΡΕΛΑΙΟΥ
3500cc



10.672
ΦΙΛΤΡΟ ΠΕΤΡΕΛΑΙΟΥ
2000-3500cc



10.673
ΦΙΛΤΡΟ ΠΕΤΡΕΛΑΙΟΥ 90°
2000cc



10.674
ΦΙΛΤΡΟ ΠΕΤΡΕΛΑΙΟΥ
2000cc



10.681
ΦΙΛΤΡΟ ΒΕΝΖΙΝΗΣ
2000-3500cc



10.682
ΦΙΛΤΡΟ ΒΕΝΖΙΝΗΣ 90°
1500cc



10.683
ΦΙΛΤΡΟ ΒΕΝΖΙΝΗΣ
2000cc



ΦΙΛΤΡΟ ΝΕΡΟΥ
95.063 19-25mm
95.064 32-38mm



ΦΙΛΤΡΟ ΝΕΡΟΥ
95.069 13-19mm
95.070 32-38mm



10.685
ΦΙΛΤΡΟ ΓΥΑΛΙΝΟ
ΜΕ ΡΑΚΟΡ



10.686
ΑΝΤΑΛΛΑΚΤΙΚΟ
ΓΙΑ ΓΥΑΛΙΝΟ ΦΙΛΤΡΟ 10.685



95.076
ΦΙΛΤΡΟ ΨΥΞΗΣ
ΜΗΧΑΝΗΣ 19mm



95.078 - ΦΙΛΤΡΟ ΝΕΡΟΥ 3/4"
95.905 - ΦΙΛΤΡΟ ΝΕΡΟΥ 1 1/2"



ΦΙΛΤΡΟ ΝΕΡΟΥ
ΙΝΟΧ

- 95.051** 3/4"
- 95.052** 1"
- 95.053** 1 1/4"
- 95.054** 1 1/2"
- 95.055** 2"
- 95.056** 2 1/2"
- 95.057** 3"



10.687
ΥΔΑΤΟΠΑΓΙΔΑ ΜΕ ΦΙΛΤΡΟ
ΜΕ ΒΑΣΗ ΟΡΕΙΧΑΛΚΙΝΗ



95.908
ΦΙΛΤΡΟ ΝΕΡΟΥ
ΜΕ ΙΝΟΧ ΠΛΕΓΜΑ 19mm



ΑΝΤΑΛ/ΚΟ ΦΙΛΤΡΟ
10.675 ΕΩΣ 500HP
10.676 ΕΩΣ 500HP



10.692
ΡΑΚΟΡ ΣΥΝΔΕΣΗΣ
ΤΡΟΦΟΔΟΣΙΑΣ
LUCAS 10.691



10.978
ΑΝΤΑΛ/ΚΟ ΦΙΛΤΡΟ LUCAS



10.688
ΥΔΑΤΟΠΑΓΙΔΑ ΜΕΣΑΙΑ
ΜΕ ΦΙΛΤΡΟ



10.689
ΡΑΚΟΡ ΣΥΝΔΕΣΗΣ
ΤΡΟΦΟΔΟΣΙΑΣ
ΜΕΣΑΙΑΣ ΥΔΑΤΟΠΑΓΙΔΑΣ
10.688



10.691
ΥΔΑΤΟΠΑΓΙΔΑ ΠΕΤΡΕΛΑΙΟΥ
LUCAS ΜΕ ΦΙΛΤΡΟ



ΥΔΑΤΟΠΑΓΙΔΑ ΠΕΤΡΕΛΑΙΟΥ
ΓΙΑ ΜΗΧΑΝΕΣ
96.407 ΕΩΣ 500HP
96.408 ΕΩΣ 900HP

NEW



96.424

ΥΔΑΤΟΠΑΓΙΔΑ ΥΑΜΑΝΑ ΠΛΑΣΤΙΚΟ ΚΑΠΑΚΙ



96.444

ΥΔΑΤΟΠΑΓΙΔΑ ΤΥΠΟΥ RACOR S3227



96.439

ΥΔΑΤΟΠΑΓΙΔΑ MERCURY ΜΕ ΠΛΑΣΤΙΚΟ ΚΑΠΑΚΙ S3213



96.474

ΑΝΤΑΛΛΑΚΤΙΚΟ S3227



96.436

ΑΝΤΑΛΛΑΚΤΙΚΟ ΦΙΛΤΡΟ ΥΑΜΑΝΑ



96.445

ΑΝΤΑΛΛΑΚΤΙΚΟ ΦΙΛΤΡΟ RACOR ΜΕΓΑΛΗ ΤΡΥΠΑ S3227



96.450

ΑΝΤΑΛΛΑΚΤΙΚΟ MERCURY ΜΕ ΠΛΑΣΤΙΚΟ ΚΑΠΑΚΙ S3213



96.440

ΑΝΤΑΛΛΑΚΤΙΚΟ ΦΙΛΤΡΟ ΥΔΑΤΟΠΑΓΙΔΑΣ MERCURY



96.468

ΥΔΑΤΟΠΑΓΙΔΑ ΥΑΜΑΝΑ MINI



96.437

ΥΔΑΤΟΠΑΓΙΔΑ MERCURY ΤΥΦΛΟ



96.490

ΥΔΑΤΟΠΑΓΙΔΑ OMC ΤΥΦΛΟ ΜΕ ΓΥΑΛΙ



96.472

ΥΔΑΤΟΠΑΓΙΔΑ OMC S3214



96.469

ΑΝΤΑΛΛΑΚΤΙΚΟ ΥΔΑΤΟΠΑΓΙΔΑΣ ΥΑΜΑΝΑ MINI



96.438

ΑΝΤΑΛΛΑΚΤΙΚΟ MERCURY ΤΥΦΛΟ



96.491

ΑΝΤΑΛΛΑΚΤΙΚΟ ΥΔΑΤΟΠΑΓΙΔΑΣ OMC ΤΥΦΛΟ



96.477

ΑΝΤΑΛΛΑΚΤΙΚΟ RACOR 3214



96.471

ΑΝΤΑΛΛΑΚΤΙΚΟ ΓΥΑΛΑΚΙ ΥΔΑΤΟΠΑΓΙΔΑΣ



96.446

ΡΑΚΟΡ ΥΑΤΟΠΑΓΙΔΑΣ ΣΕΤ



96.451

ΑΝΤΑΛΛΑΚΤΙΚΟ ΦΙΛΤΡΟ ΛΑΔΙΟΥ MERCURUISER



96.478

ΑΝΤΑΛΛΑΚΤΙΚΟ ΥΔΑΤΟΠΑΓΙΔΑΣ S3214 ΜΕ ΓΥΑΛΙ



ΑΝΤΛΙΑ ΣΕΝΤΙΝΑΣ ΑΥΤΟΜΑΤΗ

16.314	500GPH 12V	19mm
16.315	1000GPH 12V	29mm
16.316	1500GPH 12V	29mm
16.320	1500GPH 24V	29mm



ΑΝΤΛΙΑ ΣΕΝΤΙΝΑΣ ΑΥΤΟΜΑΤΗ

16.036	500GPH 12V	19mm
16.035	800GPH 12V	19mm
16.038	1200GPH 12V	29mm



ΑΝΤΛΙΑ ΑΥΤΟΜΑΤΗ

16.554	600GPH 12V
16.555	750GPH 12V
16.556	1100GPH 12V
16.555B	750GPH 24V
16.556B	1100GPH 24V



ΑΝΤΛΙΑ ΣΕΝΤΙΝΑΣ ΑΥΤΟΜΑΤΗ

16.534	600GPH 12V	19mm
16.535	750GPH 12V	19mm
16.529	750GPH 24V	19mm
16.545	1100GPH 12V	29mm
16.546	1100GPH 24V	29mm



16.319

ΑΝΤΛΙΑ ΑΥΤΟΜΑΤΗ ΗΛΕΚΤΡΙΚΗ 600GPH ANA 15 min 19mm



16.311

ΑΝΤΛΙΑ ΧΑΜΗΛΟΥ ΠΡΟΦΙΛ ΑΥΤΟΜΑΤΗ 800GPH 12V



NEW

ΑΝΤΛΙΑ ΣΕΝΤΙΝΑΣ ΑΥΤΟΜΑΤΗ
800GPH
16.561A 12V / 16.561B 24V



NEW

ΑΝΤΛΙΑ ΣΕΝΤΙΝΑΣ ΑΥΤΟΜΑΤΗ
1200GPH
16.562A 12V / 16.562B 24V



NEW

ΑΝΤΛΙΑ ΣΕΝΤΙΝΑΣ ΟΡΘΙΑ
18.591A 1500GPH 12V
18.591B 1500GPH 24V
18.592A 2000GPH 12V
18.592B 2000GPH 24V



ΑΝΤΛΙΑ ΣΕΝΤΙΝΑΣ ΝΕΟΥ ΤΥΠΟΥ

ΚΩΔΙΚΟΣ	GPH	Volts	Current	Head	ΔΙΑΜ. ΕΞΟΔΟΥ
18.581	600GPH	12V	2.5A	2.5m/7.5'	19mm
18.582A	800GPH	12V	3.5A	3.0m/9.0'	29mm
18.582B	800GPH	24V	2.0A	3.0m/9.0'	29mm
18.583A	1100GPH	12V	4.0A	4.0m/12.0'	29mm
18.583B	1100GPH	24V	2.5A	4.0m/12.0'	29mm



ΑΝΤΛΙΑ ΣΕΝΤΙΝΑΣ Ν. ΤΥΠΟΥ

- 18.518 350GPH 12V
- 18.519 600GPH 12V



ΑΝΤΛΙΑ ΣΕΝΤΙΝΑΣ

- 16.540 3000GPH 12V 38mm
- 16.541 3000GPH 24V 38mm



ΑΝΤΛΙΑ ΣΕΝΤΙΝΑΣ

- 16.542 1500GPH 12V 29mm
- 16.537 2000GPH 12V 29mm
- 16.536 1500GPH 24V 29mm
- 16.538 2000GPH 24V 29mm



ΑΝΤΛΙΑ ΣΕΝΤΙΝΑΣ ΣΤΕΝΗ

- 18.525 500GPH 12V 19mm
- 18.526 750GPH 12V 19mm
- 18.537 750GPH 24V 19mm
- 18.530 1100GPH 12V 29mm
- 18.531 1100GPH 24V 29mm



**ΑΝΤΛΙΑ ΣΕΝΤΙΝΑΣ
ΕΞΑΓΩΓΗ ΑΠΟ ΕΠΑΝΩ**

- 16.317 1000GPH 12V 19-28mm
- 16.318 1750GPH 12V 19-28 mm



ΑΝΤΛΙΑ ΣΕΝΤΙΝΑΣ ΣΤΕΝΗ

- 16.312 500GPH 12V 19mm
- 16.313 1000GPH 12V 28mm

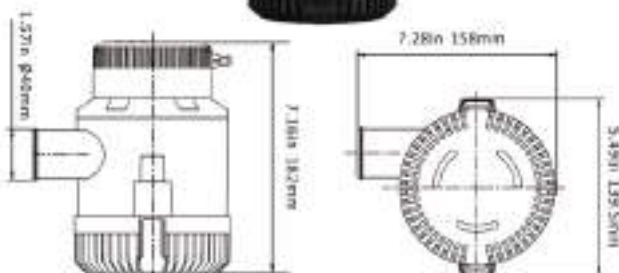

ΑΝΤΛΙΑ ΣΕΝΤΙΝΑΣ 3700GPH

- 16.547A - 12V
- 16.547B - 24V

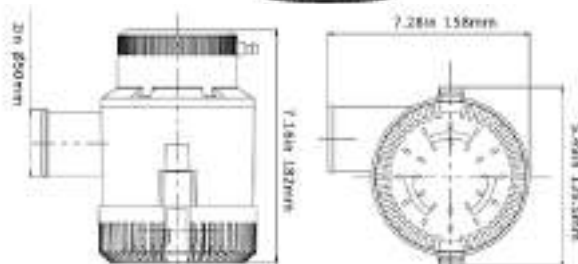

ΑΝΤΛΙΑ ΣΕΝΤΙΝΑΣ 4700GPH

- 16.548A - 12V
- 16.548B - 24V



ΑΝΤΛΙΑ ΣΕΝΤΙΝΑΣ

- 16.001 400GPH 12V 19mm
- 16.002 600GPH 12V 19mm
- 16.004 1400GPH 12V 29mm
- 16.005 1750GPH 12V 29mm
- 16.006 2300GPH 12V 38mm
- 16.011 1400GPH 24V 29mm
- 16.012 1750GPH 24V 29mm
- 16.013 2300GPH 24V 38mm



ΑΝΤΛΙΑ ΣΕΝΤΙΝΑΣ

- 16.014 450GPH 12V 19mm
- 16.015 900GPH 12V 29mm
- 16.016 1250GPH 12V 29mm



ΑΝΤΛΙΑ ΣΕΝΤΙΝΑΣ

- 16.031 500GPH 12V 19mm
- 16.033 800GPH 12V 19mm
- 16.034 1200GPH 12V 28mm



16.051

ΑΝΤΛΙΑΚΙ ΒΑΡΕΛΙΟΥ ΚΑΡΑΒΑΝ 7.7Lt 12V



16.052

ΑΝΤΛΙΑΚΙ ΒΑΡΕΛΙΟΥ ΚΑΡΑΒΑΝ 11Lt 12V



16.053

ΑΝΤΛΙΑΚΙ ΝΕΡΟΥ 280GPH 12V



16.054

ΑΝΤΛΙΑΚΙ ΒΑΡΕΛΙΟΥ 12 LPM 12V

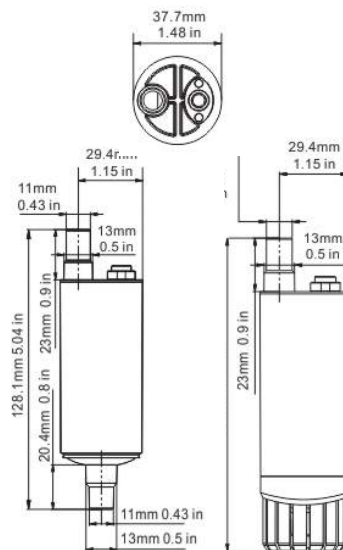

ΑΝΤΛΙΑΚΙ ΝΕΡΟ-ΛΑΔΙ-DIESEL

16.055 200GPH 12V

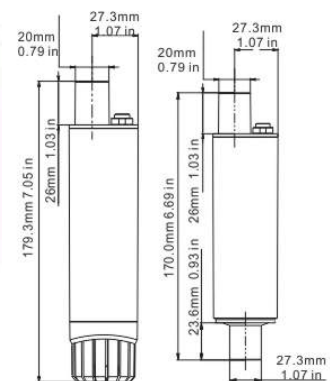

ΑΝΤΛΙΑΚΙ ΝΕΡΟ-ΛΑΔΙ-DIESEL

16.056 500GPH 12V

ΦΛΟΤΕΡ ΣΕΝΤΙΝΑΣ

ΥΔΡΑΥΛΙΚΟΣ ΕΞΟΠΛΙΣΜΟΣ

SEAFLO



16.042

ΦΛΟΤΕΡ ΣΕΝΤΙΝΑΣ 10-30V

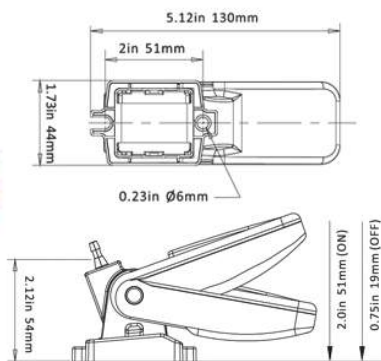

SEAFLO



16.043

ΦΛΟΤΕΡ ΣΕΝΤΙΝΑΣ ΜΕΓΑΛΟ ΜΕ ΜΠΙΛΙΑ 10-30V

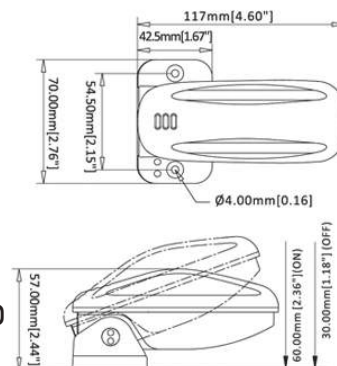

16.032

ΦΛΟΤΕΡ ΗΛΕΚΤΡΟΜΑΓΝΗΤΙΚΟ

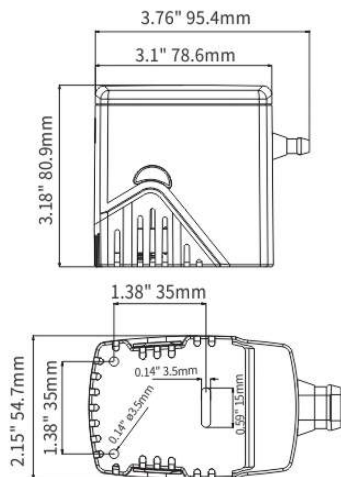

SEAFLO



ΦΛΟΤΕΡ ΤΕΤΡΑΓΩΝΟ

16.044 15A 10-30V 16.046 25A 10-30V

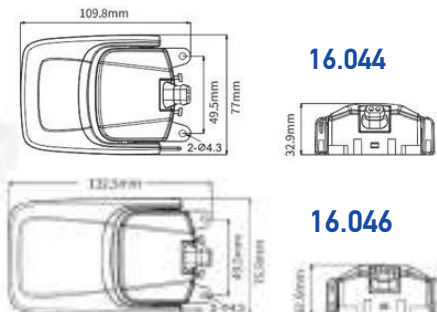

16.044

16.046



16.021

ΦΛΟΤΕΡ ΣΕΝΤΙΝΑΣ 10-30V



16.045

ΦΛΟΤΕΡ SEAFLO ΤΕΤΡΑΓΩΝΟ 15A ΜΕ ΚΑΛΥΜΜΑ



16.039

ΦΛΟΤΕΡ ΣΕΝΤΙΝΩΝ ΜΕ ΑΛΑΡΜ



NEW

16.030
ΦΛΟΤΕΡ ΗΛΕΚΤΡΟ ΜΑΓΝΗΤΙΚΟ



NEW

ΠΙΝΑΚΑΣ ΑΝΤΙΑΣ ΣΕΝΤΙΝΑΣ ΜΕ ΑΛΑΡΜ

16.047A 12V / 16.47B 24V

ΑΝΤΛΙΕΣ ΧΕΙΡΟΚΙΝΗΤΕΣ

ΥΔΡΑΥΛΙΚΟΣ ΕΞΟΠΛΙΣΜΟΣ



ΑΝΤΛΙΑ ΛΑΔΙΟΥ ΧΕΙΡΟΚΙΝΗΤΗ

16.092 4,0 Lt
16.093 6,5 Lt



16.091

ΑΝΤΛΙΑ ΛΑΔΙΟΥ ΧΕΙΡΟΚΙΝΗΤΗ



16.103

ΑΝΤΛΙΑ ΣΕΝΤΙΝΩΝ ΧΕΙΡΟΚΙΝΗΤΗ ΜΕ ΣΩΛΗΝΑ L950mm



ΑΝΤΛΙΑ ΣΕΝΤΙΝΑΣ ΧΕΙΡΟΚΙΝΗΤΗ

16.102A 1 1/2"
16.102B 1"



16.101

ΑΝΤΛΙΑ ΣΕΝΤΙΝΑΣ ΠΟΔΟΚΙΝΗΤΗ



16.061 - ΑΝΤΛΙΑ ΠΑΛΙΔΡΟΜΙΚΗ
12V 20rpm 19m

16.064 - ΑΝΤΛΙΑ ΠΑΛΙΔΡΟΜΙΚΗ
24V 20rpm 19m



16.081 - ΑΝΤΛΙΑΚΙ ΚΟΥΖΙΝΑΣ 12V
ΜΕ ΒΡΥΣΗ

16.082 - ΑΝΤΛΙΑΚΙ ΚΟΥΖΙΝΑΣ 12V



16.551A - ΑΝΤΛΙΑ ΠΡΕΣΟΣΤΑΤΙΚΗ
ΚΛΕΙΣΤΗ 5,6LPM 40PSI 12V

16.551B - ΑΝΤΛΙΑ ΠΡΕΣΟΣΤΑΤΙΚΗ
ΚΛΕΙΣΤΗ 5,6LPM 40PSI 24V



16.531A - ΑΝΤΛΙΑ ΠΡΕΣΟΣΤΑΤΙΚΗ
4,3 LPM 12V 35PSI

16.531B - ΑΝΤΛΙΑ ΠΡΕΣΟΣΤΑΤΙΚΗ
4,3 LPM 24V 35PSI



16.532A - ΑΝΤΛΙΑ ΠΡΕΣΟΣΤΑΤΙΚΗ
5 LPM 12V 80PSI

16.532B - ΑΝΤΛΙΑ ΠΡΕΣΟΣΤΑΤΙΚΗ
5 LPM 24V 80PSI



18.543
ΑΝΤΛΙΑ ΟΞΥΓΟΝΩΣΗΣ
ΝΕΡΟΥ 350GPH 12V
(ΓΙΑ ΖΩΝΤΑΝΟ ΔΟΛΩΜΑ)

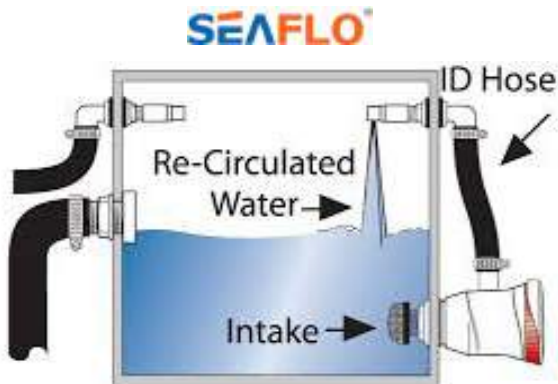

18.556

ΑΝΤΛΙΑ ΟΞΥΓΟΝΩΣΗΣ ΝΕΡΟΥ ΜΕ
ΥΔΡΟΡΡΟΗ ΙΣΙΑ 12V 600GPH
(ΓΙΑ ΖΩΝΤΑΝΟ ΔΟΛΩΜΑ)



18.546

ΑΝΤΛΙΑ ΟΞΥΓΟΝΩΣΗΣ
ΝΕΡΟΥ ΜΕ ΥΔΡΟΡΡΟΗ
ΓΩΝΙΑΚΗ 350GPH 12V
(ΓΙΑ ΖΩΝΤΑΝΟ ΔΟΛΩΜΑ)



18.553

ΑΝΤΛΙΑ ΟΞΥΓΟΝΩΣΗΣ ΝΕΡΟΥ
350GPH ΜΕ ΠΛΑΣΤΙΚΗ ΣΩΛΗΝΑ



18.554

ΑΝΤΛΙΑ ΟΞΥΓΟΝΩΣΗΣ ΝΕΡΟΥ
350GPH ΜΕ ΕΥΚΑΜΠΤΗ ΣΩΛΗΝΑ



16.539
ΣΥΣΤΗΜΑ ΠΛΥΣΙΜΑΤΟΣ ΦΟΡΗΤΟ
8,5 LPM 100PSI



ΑΝΤΛΙΑ ΠΡΕΣΟΣΤΑΤΙΚΗ
5.0 - 70PSI 18,9LT
VARIABLE SPEED S-CHAMBER
18.574A 12V / 18.574B 24V

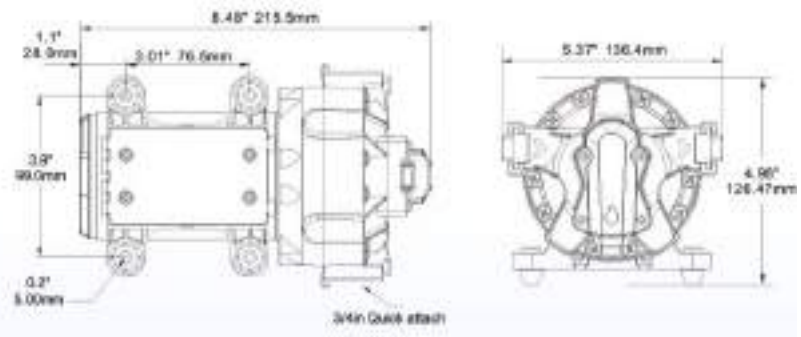

ΑΝΤΛΙΑ ΠΡΕΣΟΣΤΑΤΙΚΗ
ΜΕ ΣΥΣΤΗΜΑ BY-PASS
18.571 26,5 LPM 60PSI 12V
18.572 26,5 LPM 60PSI 24V

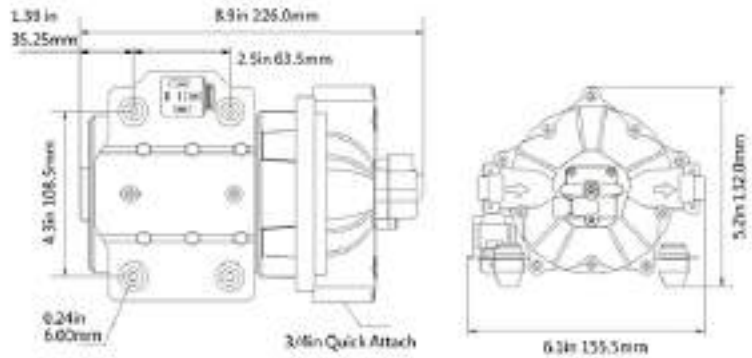

ΑΝΤΛΙΑ ΠΡΕΣΟΣΤΑΤΙΚΗ
18.524 17 LPM 40 PSI 12V
18.529 17 LPM 40 PSI 24V

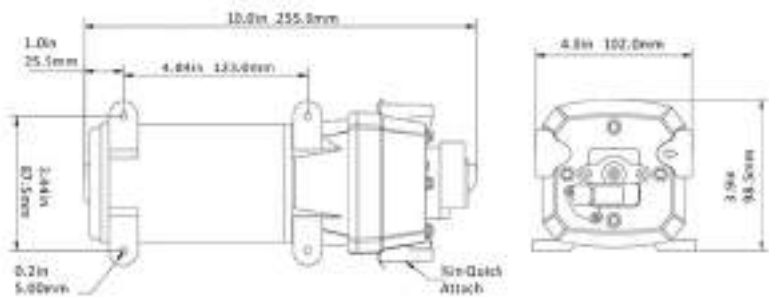

18.522A - ΑΝΤΛΙΑ ΠΡΕΣΟΣΤΑΤΙΚΗ
N.T. 11,3 LPM 45PSI 12V
18.522B - ΑΝΤΛΙΑ ΠΡΕΣΟΣΤΑΤΙΚΗ
N.T. 11,3 LPM 45PSI 24V

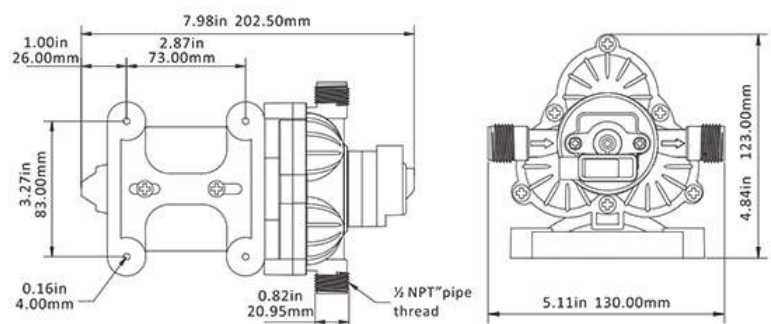



**ΑΝΤΛΙΑ ΠΡΕΣΟΣΤΑΤΙΚΗ
ΜΕ ΣΥΣΤΗΜΑ BY-PASS**

18.541 15 LPM 55PSI 12V
18.542 15 LPM 55PSI 24V

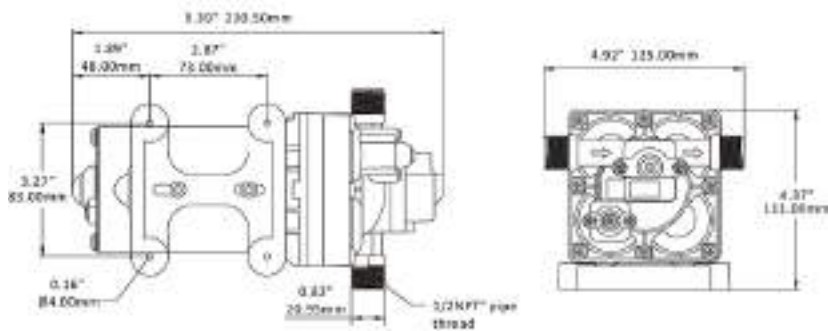

18.533

**ΑΝΤΛΙΑ ΠΡΕΣΟΣΤΑΤΙΚΗ
12,5LPM 35PSI 12V**

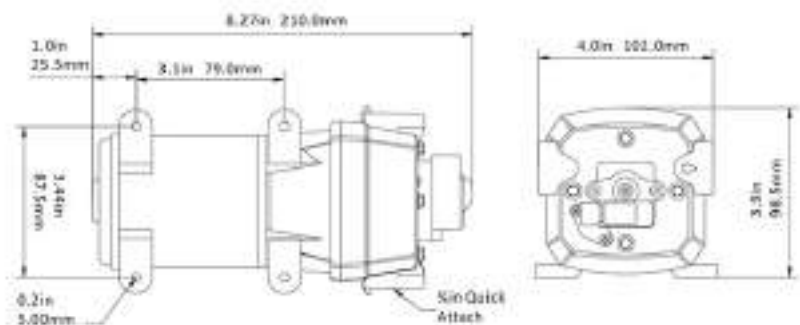

**ΑΝΤΛΙΑ ΠΡΕΣΟΣΤΑΤΙΚΗ
ΜΕ ΣΥΣΤΗΜΑ BY-PASS**

18.528 11.3 LPM 55 PSI 12V
18.538 11.3 LPM 55 PSI 24V

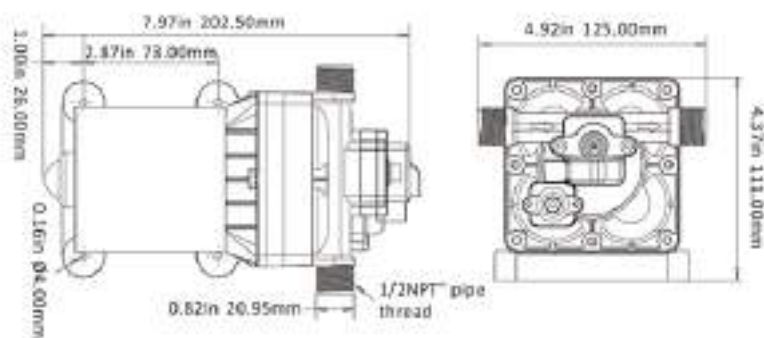

**ΑΝΤΛΙΑ ΠΡΕΣΟΣΤΑΤΙΚΗ
8.3 LPM 30PSI**

18.532A 12V **18.532B** 24V

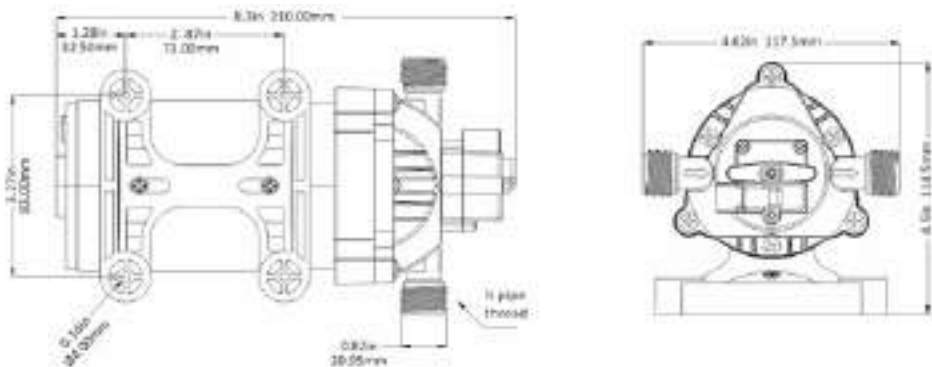

**18.521A - ΑΝΤΛΙΑ ΠΡΕΣΟΣΤΑΤΙΚΗ
N.T. 18,9l 60psi 12V**

**18.521B - ΑΝΤΛΙΑ ΠΡΕΣΟΣΤΑΤΙΚΗ
N.T. 18,9l 60 psi 24V**

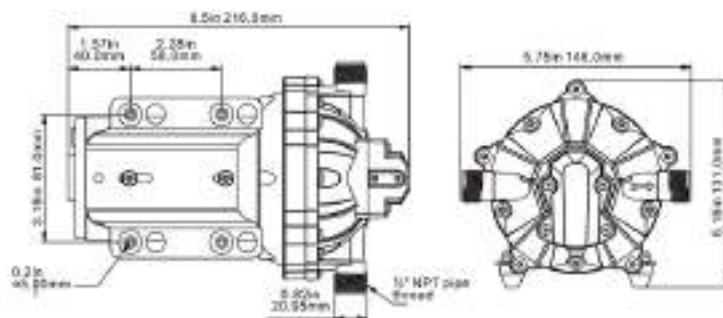



**ΑΝΤΛΙΑ ΥΓΡΩΝ (ΛΑΔΙΟΥ)
ΜΕ ΓΡΑΝΑΖΙ**
18.544 12V 12LPM
18.545 24V 12LPM

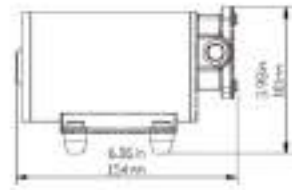
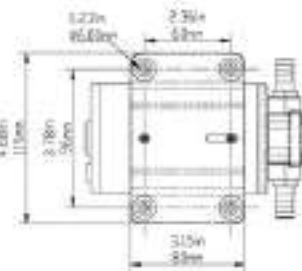
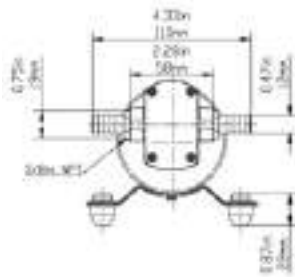

18.573
**ΑΝΤΛΙΑ ΚΥΚΛΟΦΟΡΗΤΗΣ-
AIRCONDITION 31LPM 230V**

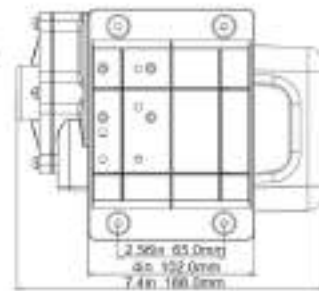
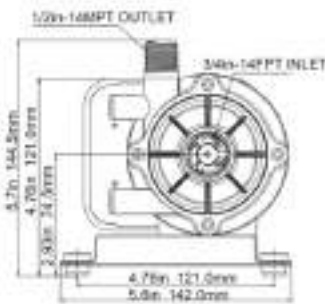

**ΑΝΤΛΙΑ ΠΡΕΣ/ΚΗ ΜΕ ΔΕΞΑΜΕΝΗ
ΣΥΣΣΩΡΕΥΣΗΣ ΝΕΡΟΥ 8 lt**
18.535 11.5 LPM 60PSI 12V
18.536 11.5 LPM 60PSI 24V

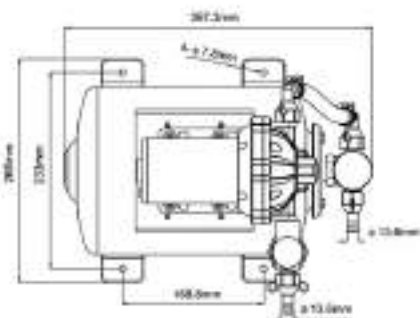
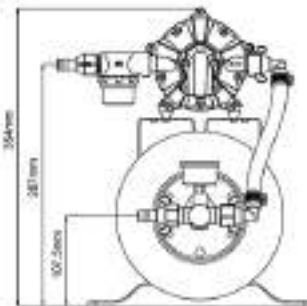

**ΔΕΞΑΜΕΝΗ ΣΥΣΣΩΡΕΥΣΗΣ
ΝΕΡΟΥ (ACUMULATOR)**
18.534 0,75lit
18.539 1lit

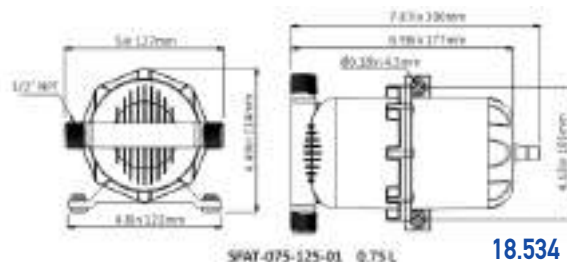

SPAT-075-125-01 0.75L

18.534

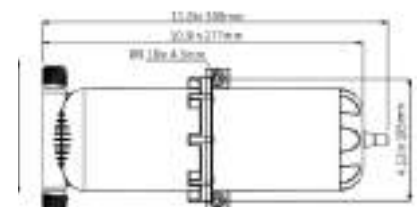

T-100-125-01 1.0L

18.539



ΑΝΤΛΙΑ ΜΕ ΙΜΠΕΛΕΡ ΜΕ ΠΛΑΣΤΙΚΗ ΚΕΦΑΛΗ

18.559A 30LPM 12V

18.559B 30LPM 24V

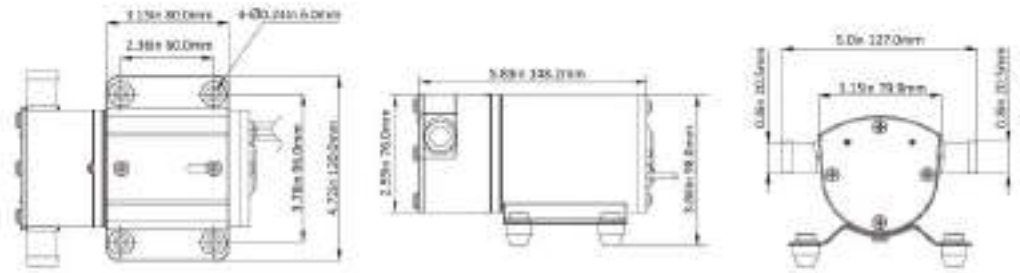

ΑΝΤΛΙΑ ΜΕ ΙΜΠΕΛΕΡ

18.549 12V 30 LPM

18.550 24V 30 LPM

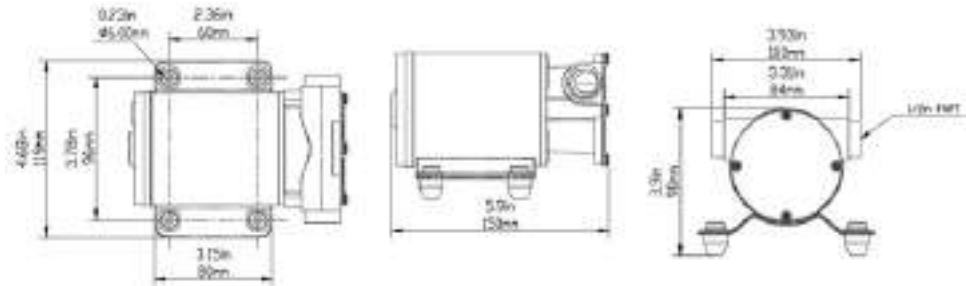

16.208A

ΑΝΤΛΙΑ ΠΡΕΣΟΣΤΑΤΙΚΗ ΓΙΑ QUIET FLUSH ΤΟΥΑΛΕΤΑ
lpm15 50psi 12V B 24V

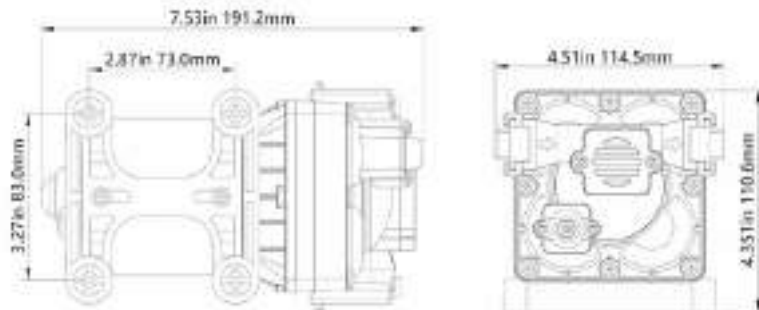

16.533

ΣΥΣΤΗΜΑ ΠΛΥΣΙΜΑΤΟΣ ΜΟΝΙΜΗΣ ΤΟΠΟΘΕΤΗΣΗΣ
11,6 LPM 70PSI

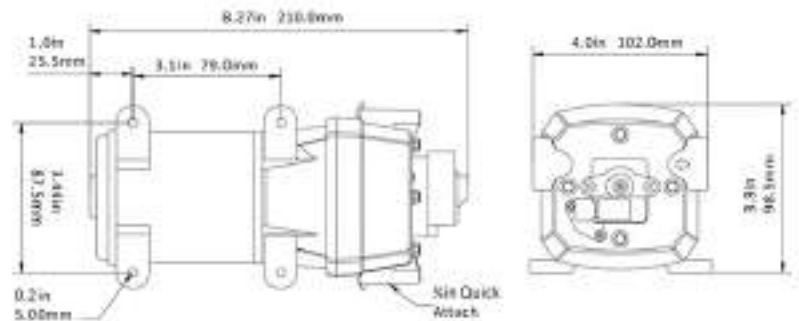



18.558
ΦΙΛΤΡΟ ΠΡΕΣΤΟΣΤΑΤΙΚΗΣ ΑΝΤΛΙΑΣ
ΜΕ ΣΠΕΙΡΩΜΑ



18.552
ΦΙΛΤΡΟ ΠΡΕΣΤΟΣΤΑΤΙΚΗΣ
ΑΝΤΛΙΑΣ



18.551
ΙΜΠΕΛΕΡ ΑΝΤΛΙΑΣ



18.563
ΡΑΚΟΡ ΑΝΤΛΙΑΣ ΠΡΕΣΤΟΣΤΑΤΙΚΗΣ 1/2"



18.564
ΡΑΚΟΡ ΑΝΤΛΙΑΣ ΠΡΕΣΤΟΣΤΑΤΙΚΗΣ
ΜΕ ΣΠΕΙΡΩΜΑ 1/2"



18.566
ΡΑΚΟΡ ΓΩΝΙΑΚΟ ΑΝΤΛΙΑΣ
ΠΡΕΣΤΟΣΤΑΤΙΚΗΣ ΓΩΝΙΑΚΟ 1/2"



18.565
ΡΑΚΟΡ ΑΝΤΛΙΑΣ ΠΡΕΣΤΟΣΤΑΤΙΚΗΣ
1/2" ΜΕ ΣΠΕΙΡΩΜΑ



18.568
ΡΑΚΟΡ ΑΝΤΛΙΑΣ ΠΡΕΣΤΟΣΤΑΤΙΚΗΣ
ΓΩΝΙΑ 1/2" ΜΕ ΣΠΕΙΡΩΜΑ ΘΗΛΥΚΟ



**ΡΑΚΟΡ ΑΝΤΛΙΑΣ ΠΡΕΣΤΟΣΤΑΤΙΚΗΣ
ΓΙΑ 16.531 - 16.532**
18.561 - 3/8"
18.562 - 1/2"



18.560
ΡΑΚΟΡ ΠΡΕΣΤΟΣΤΑΤΙΚΗΣ 3/4 ΟΑ



18.569
ΡΑΚΟΡ ΓΩΝΙΑΚΟ ΑΝΤΛΙΑΣ ΠΡΕΣ/ΚΗΣ
1/2" ΜΕ ΣΠΕΙΡΩΜΑ ΑΡΣΕΝΙΚΟ



18.567
ΡΑΚΟΡ ΑΝΤΛΙΑΣ ΛΑΔΙΟΥ



18.570
ΧΕΙΡΙΣΤΗΡΙΟ ΑΝΤΛΙΑΣ WIRELESS



18.548
ΠΡΕΣΤΟΣΤΑΤΗΣ 51 SERIES ΑΝΤΛΙΑΣ



18.547
ΠΡΕΣΤΟΣΤΑΤΗΣ
A 35PSI
B 40PSI
C 45PSI
D 60PSI
E 70PSI
F 80PSI



85.130
ΚΑΛΩΔΙΟ ΜΕ ΚΡΟΚΟΔΕΙΛΑΚΙΑ



85.131
ΚΑΛΩΔΙΟ ΜΕ ΠΡΙΖΑ ΑΝΑΠΤΗΡΑ



85.132
ΚΑΛΩΔΙΟ ΜΕ ΠΡΙΖΑ ΔΙΠΟΛΙΚΗ
ΑΝΤΛΙΑΣ ΚΑΙ ΔΙΑΚΟΠΤΗ



94.037
ΣΕΤ ΝΤΟΥΣ ΙΝΟΧ ΜΕ 2,5 ΜΤ
ΣΩΛΗΝΑ



94.024
ΝΤΟΥΣ ΙΝΟΧ 2,5ΜΤ
ΜΕ ΜΗΧΑΝΙΣΜΟ ΙΣΙΟ



ΝΤΟΥΣ SATURN (ΖΕΣΤΟ-ΚΡΥΟ)
94.045 ΚΑΘΕΤΟ **94.046** ΟΡΙΖΟΝΤΙΟ



94.028
ΑΝΤΑΠΤΟΡΑΣ ΝΤΟΥΣ 3/8" -1/2"



94.033
ΘΗΚΗ ΜΕ ΑΝΤΑΠΤΟΡΑ
ΓΙΑ ΤΗΝ ΤΑΧΕΙΑ ΕΞΟΔΟ ΤΟΥ ΝΕΡΟΥ



94.029
ΘΗΚΗ ΜΕ ΑΝΤΑΠΤΟΡΑ ΓΙΑ
ΓΡΗΓΟΡΗ ΕΙΣΟΔΟ ΤΟΥ ΝΕΡΟΥ



94.038
ΑΝΤΑΛΛΑΚΤΙΚΟ ΝΤΟΥΣ
ΙΝΟΧ



94.039
ΝΤΟΥΣ ΑΝΤΑΛΛΑΚΤΙΚΟ
ΙΝΟΧ



94.035
ΚΟΝΕΚΤΟΡΑΣ ΠΛΥΣΙΜΑΤΟΣ ΚΑΤΑΣΤΡΩΜΑΤΟΣ SS316



94.051
ΑΝΤΑΛΛΑΚΤΙΚΟΣ
ΚΟΝΕΚΤΟΡΑΣ ΛΟΞΟΣ



94.052
ΑΝΤΑΛΛΑΚΤΙΚΟΣ
ΚΟΝΕΚΤΟΡΑΣ ΙΣΙΟΣ



94.036
ΝΤΟΥΣ ΣΩΛΗΝΑΣ 2,5 ΙΝΟΧ
1/2" x 1/2"



94.018
ΝΤΟΥΣ ΣΩΛΗΝΑΣ PVC 2.5ΜΤ
1/2"-1/2" SILVER



94.020 ΝΤΟΥΣ ΣΩΛΗΝΑΣ 2.5 m 1/2" x 1/2"
94.021 ΝΤΟΥΣ ΣΩΛΗΝΑΣ 5 m 1/2" x 1/2"
94.022 ΝΤΟΥΣ ΣΩΛΗΝΑΣ 3m 1/2" x 3/8"



94.025
ΑΝΤΑΛΛΑΚΤΙΚΟ ΝΤΟΥΖΙΕΡΑΣ ΙΣΙΟ



94.026
ΑΝΤΑΛΛΑΚΤΙΚΟ ΙΣΙΟ ΝΤΟΥΖΙΕΡΑΣ ΛΕΥΚΟ



94.032
ΚΙΤ ΜΙΚΤΗ ΝΕΡΟΥ



94.013
ΝΤΟΥΣ ΧΡΩΜΙΟΥ



94.023
ΝΤΟΥΣ ΛΕΥΚΟΣ



94.034
ΘΗΚΗ ΜΙΚΤΗ ΝΕΡΟΥ



94.030
ΘΗΚΗ ΙΣΙΑΣ ΝΤΟΥΖΙΕΡΑΣ



94.031
ΘΗΚΗ ΓΙΑ ΜΙΚΤΗ ΝΕΡΟΥ ΚΑΙ ΝΤΟΥΖΙΕΡΑΣ



94.010
ΘΗΚΗ ΓΙΑ ΝΤΟΥΣ ΛΕΥΚΗ



94.041
ΘΗΚΗ ΙΣΙΑΣ ΝΤΟΥΖΙΕΡΑΣ ΧΡΩΜΙΟΜΕΝΗ



94.042
ΘΗΚΗ ΓΙΑ ΝΤΟΥΣ ΧΡΩΜΙΟΜΕΝΗ



94.043
ΘΗΚΗ ΜΙΚΤΗ ΝΕΡΟΥ ΧΡΩΜΙΟΜΕΝΗ

ΔΕΞΑΜΕΝΗ ΝΕΡΟΥ ΜΕ ΠΡΕΣΟΣΤΑΤΙΚΗ ΑΝΤΛΙΑ 4 LPM

ΚΩΔ.	ΧΩΡΗΤ/ΤΑ Lt	ΜΗΚΟΣ mm	ΥΨΟΣ mm	ΠΛΑΤΟΣ mm	ΒΑΡΟΣ kg	ΜΕΤΡΗΤΗΣ 10/180Ω
96.700	39	550	200	390	13,9	31.017
96.701	45	650	200	390	4,0	31.017
96.702	52	750	200	390	4,5	31.017
96.703	60	850	200	390	5,0	31.017
96.704	65	950	200	390	5,5	31.017
96.705	71	1050	200	390	7,5	31.017
96.706	57	550	290	390	4,2	31.028
96.707	67	650	290	390	4,8	31.028
96.708	77	750	290	390	5,0	31.028
96.709	87	850	290	390	5,5	31.028
96.710	97	950	290	390	6,5	31.028
96.711	107	1050	290	390	8,0	31.028



ΔΕΞΑΜΕΝΗ ΝΕΡΟΥ

ΚΩΔΙΚΟΣ	ΚΩΔΙΚΟΣ	ΧΩΡΗΤ/ΤΑ Lt	ΜΗΚΟΣ mm	ΥΨΟΣ mm	ΠΛΑΤΟΣ mm
96.031	96.031-A	32	450	200	390
96.032	96.032-A	39	550	200	390
96.033	96.033-A	45	650	200	390
96.034	96.034-A	52	750	200	390
96.035	96.035-A	60	850	200	390
96.036	96.036-A	65	950	200	390
96.037	96.037-A	71	1050	200	390
96.041	96.041-A	47	450	290	390
96.042	96.042-A	57	550	290	390
96.043	96.043-A	67	650	290	390
96.044	96.044-A	77	750	290	390
96.045	96.045-A	87	850	290	390
96.046	96.046-A	97	950	290	390
96.047	96.047-A	107	1050	290	390



ΜΕΤΡΗΤΕΣ ΗΛΕΚΤΡΙΚΟΙ ΚΑΥΣΙΜΟΥ-ΝΕΡΟΥ

ΚΩΔ.	10/180 Ω	ΚΩΔ.	240/33 Ω
31.015	15cm	31.115	15cm
31.017	17cm	31.117	17cm
31.020	20cm	31.120	20cm
31.022	22cm	31.122	22cm
31.025	25cm	31.125	25cm
31.028	28cm	31.128	28cm
31.030	30cm	31.130	30cm
31.035	35cm	31.135	35cm
31.039	39cm	31.139	39cm
31.050	50cm	31.150	50cm
31.060	60cm	31.160	60cm
31.080	80cm	31.180	80cm



10.988 - ΔΕΞΑΜΕΝΗ ΝΕΡΟΥ ΚΑΘΕΤΗ 70Lt
L66 x H(41+3) x W30cm

10.989 - ΔΕΞΑΜΕΝΗ ΝΕΡΟΥ ΚΑΘΕΤΗ 100Lt
L91 x H(41+3) x W30cm



10.990 - ΔΕΞΑΜΕΝΗ ΝΕΡΟΥ ΟΡΙΖΟΝΤΙΑ 70Lt
L66 x H(30+3) x W41cm

10.999 - ΔΕΞΑΜΕΝΗ ΝΕΡΟΥ ΟΡΙΖΟΝΤΙΑ 100Lt
L91 x H(30+3)x W41cm



32.105 - ΡΟΥΞΟΥΝΙ ΣΩΛΗΝΑ ΓΩΝΙΑΚΟ ΠΛΑΣΤΙΚΟ
ΣΠΕΙΡΩΜΑ 3-8" 12mm



ΑΣΚΟΙ ΝΕΡΟΥ ΑΠΟ ΕΛΑΣΤΟΜΕΡΕΣ ΠΛΑΣΤΙΚΟ

ΚΩΔ.	ΣΧΗΜΑ	ΧΩΡΗΤ/ΤΑ Lt	ΜΗΚΟΣ mm	ΥΨΟΣ mm	ΒΑΡΟΣ kg
10.401	ΤΕΤΡΑΓΩΝΟ	60	730	730	1,0
10.402	ΤΕΤΡΑΓΩΝΟ	75	770	730	1,1
10.403	ΤΕΤΡΑΓΩΝΟ	100	880	730	1,2
10.405	ΤΕΤΡΑΓΩΝΟ	150	1150	730	1,9
10.451	ΤΡΙΓΩΝΟ	55	950	1000	1,0
10.452	ΤΡΙΓΩΝΟ	100	1100	1100	1,3



10.979
ΡΑΚΟΡ ΝΕΡΟΥ Φ15mm ΣΧΗΜΑ Τ.



10.980
ΡΑΚΟΡ ΝΕΡΟΥ Φ15mm



10.981
ΡΑΚΟΡ ΝΕΡΟΥ Φ15mm ΓΩΝΙΑΚΟ



10.983
ΡΑΚΟΡ ΝΕΡΟΥ Φ15mm 3/8"



10.984
ΡΑΚΟΡ ΝΕΡΟΥ Φ15mm 1/2"



10.992
ΡΑΚΟΡ ΙΣΙΟ Φ15 ΘΗΛΥΚΟ-ΘΗΛΥΚΟ 3/8"



10.991
ΡΑΚΟΡ ΙΣΙΟ Φ15 ΘΗΛ.-ΘΗΛ. 1/2"



10.985
ΓΩΝΙΑΚΟ Φ15 ΜΕ ΡΟΥΞΟΥΝΙ ΑΡΣΕΝΙΚΟ



10.986
ΡΑΚΟΡ ΣΥΝΔ. ΝΕΡΟΥ Φ15 ΘΥΛ 3/4"



10.987B
ΣΩΛΗΝΑ ΝΕΡΟΥ ΚΡΥΟ Φ15



10.987A
ΣΩΛΗΝΑ ΖΕΣΤΟΥ ΝΕΡΟΥ Φ15

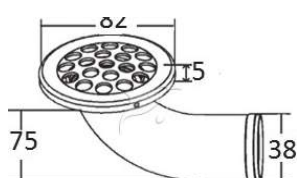

10.355
ΥΔΡΟΡΡΟΗ ΑΠΟΧΕΤΕΥΣΗΣ ΙΝΟΧ
ΓΩΝΙΑΚΗ 90° ΓΙΑ ΣΩΛΗΝΑ 38mm

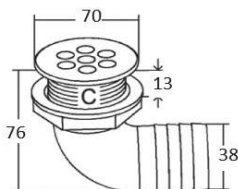

10.356
ΥΔΡΟΡΡΟΗ ΑΠΟΧΕΤΕΥΣΗΣ ΣΤΕΝΗ ΙΝΟΧ
ΓΩΝΙΑΚΗ 90° ΓΙΑ ΣΩΛΗΝΑ 38mm

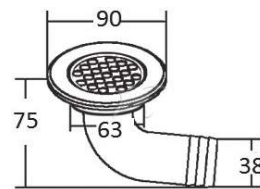

10.357
ΥΔΡΟΡΡΟΗ ΑΠΟΧΕΤΕΥΣΗΣ ΡVC
ΓΩΝΙΑΚΗ 90° ΓΙΑ ΣΩΛΗΝΑ 38mm



ΥΔΡΟΡΡΟΗ ΑΠΟΧΕΤΕΥΣΗΣ

ΚΩΔΙΚΟΣ	Amm	Bmm	Cmm	Dmm	Emm
10.359	50	82	27	38	58
10.360	50	82	27	50	72

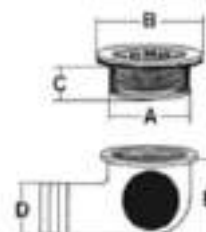



11.631
ΚΑΠΑΚΙ ΕΙΣΑΓΩΓΗΣ
ΟΒΑΛ 1 1/2" - 2"



11.641
ΚΑΠΑΚΙ ΕΙΣΑΓΩΓΗΣ
ΣΤΡΟΓΓΥΛΟ Φ100mm



ΡΑΚΟΡ ΓΩΝΙΑ TRUDESIGN

ΚΩΔΙΚΟΣ	ΔΙΑΜ. mm
93.391	19
93.392	25
93.393	38
93.394	50



ΡΑΚΟΡ ΣΩΛΗΝΑ Τ ΝΑΥΛΟΝ

ΚΩΔΙΚΟΣ	ΔΙΑΜ. mm
94.210	10
94.212	12
94.216	16
94.220	20
94.225	25



ΒΑΛΒΙΔΑ ΑΝΕΠΙΣΤΡΟΦΗ
10.475 Φ19-25mm
10.476 Φ32-38mm



ΚΟΝΕΚΤΟΡΑΣ ΜΕ
ΑΝΕΠΙΣΤΡΟΦΗ ΒΑΛΒΙΔΑ
10.471 12-20-26mm
10.472 25-32-38mm



10.473
ΚΟΝΕΚΤΟΡΑΣ
ΜΕ ΑΝΕΠΙΣΤΡΟΦΗ ΒΑΛΒΙΔΑ
1" / 1 1/2"



ΡΑΚΟΡ ΕΝΩΣΗΣ
ΜΕ ΑΝΕΠΙΣΤΡΟΦΗ

ΚΩΔ.	ΑΠΟ Ø mm	ΣΕ Ø mm
10.875	13	13
10.876	19	19
10.877	25	25
10.878	32	32
10.879	38	38
10.880	50	50



ΡΑΚΟΡ ΕΝΩΣΗΣ

ΚΩΔ.	ΑΠΟ Ø mm	ΣΕ Ø mm
10.868	13	13
10.869	19	19
10.870	25	25
10.871	32	32
10.872	38	38
10.873	50	50



ΡΑΚΟΡ ΣΥΝΔΕΣΗΣ ΣΩΛΗΝΑ

ΚΩΔ.	ΑΠΟ Ø mm	ΣΕ Ø mm
10.860	19	13
10.861	25	19
10.862	32	25
10.863	38	32
10.864	38	25
10.865	19	16
10.866	25	13



ΣΩΛΗΝΑ ΑΕΡΑΓΩΓΟΥ

15.184 Φ 70mm
15.186 Φ 100mm



ΣΩΛΗΝΑ ΒΕΝΖΙΝΗΣ ΕΝΙΣΧΥΜΕΝΗ

10.663 7mm (-20ο ΕΩΣ +60ο)
10.665 9mm (-20ο ΕΩΣ +60ο)



ΣΩΛΗΝΑΣ ΚΑΥΣΙΜΟΥ CE

10.651 8mm
94.149 10mm
94.150 12mm
94.151 16mm
94.152 19mm
94.153 25mm
94.154 38mm
94.155 50mm



ΣΩΛΗΝΑΣ ΚΑΥΣΑΕΡΙΩΝ

94.161 Φ 45mm
94.162 Φ 51mm
94.164 Φ 75mm



ΣΩΛΗΝΑΣ ΝΕΡΟΥ ΔΙΑΦΑΝΗΣ ΜΕ ΣΠΙΡΑΛ

ΚΩΔΙΚΟΣ	ΔΙΑΜΕΤΡΟΣ
94.104	Φ 13mm
94.107	Φ 16mm
94.105	Φ 19mm
94.106	Φ 25mm
94.108	Φ 30mm
94.109	Φ 38mm
94.111	Φ 45mm
94.112	Φ 50mm



ΣΩΛΗΝΑΣ ΑΚΑΘΑΡΤΩΝ ΛΕΥΚΗ ΜΕ ΣΠΙΡΑΛ

ΚΩΔΙΚΟΣ	ΔΙΑΜΕΤΡΟΣ
94.141	Φ 20mm
94.142	Φ 25mm
94.143	Φ 38mm
94.144	Φ 50mm



95.075

ΚΟΝΕΚΤΟΡΑΣ ΣΩΛΗΝΩΣΕΩΝ
32 έως 60 mm



95.074

ΚΟΝΕΚΤΟΡΑΣ ΣΩΛΗΝΩΣΕΩΝ
13 έως 38 mm



ΣΩΛΗΝΑΣ ΑΚΑΘΑΡΤΩΝ ΑΟΣΜΟΣ

94.172 25mm
94.176 38mm



ΚΟΛΙΕΔΕΣ ΙΝΟΧ SS316

ΚΩΔΙΚΟΣ	Φmm
97.100	8 - 12
97.101	10 - 16
97.102	12 - 20
97.103	16 - 25
97.104	20 - 32
97.105	30 - 45
97.106	32 - 50
97.107	40 - 60
97.108	60 - 80
97.109	80 - 100



ΒΑΛΒΙΔΕΣ ΝΕΡΟΥ PVC

ΚΩΔ.	ΣΠΕΙΡΩΜΑ
97.011	1/2"
97.012	3/4"
97.013	1"
97.014	1 1/4"
97.015	1 1/2"



ΡΑΚΟΡ ΒΑΛΒΙΔΑΣ ΝΕΡΟΥ PVC

ΚΩΔ.	ΣΠΕΙΡΩΜΑ	ΡΑΚΟΡ Φmm
93.370	1/2"	13
93.371	3/4"	19
93.372	1"	25
93.373	1 1/4"	32
93.374	1 1/4"	38
93.375	1 1/2"	38
93.376	1 1/2"	50



ΥΔΡΟΡΡΟΗ ΣΠΕΙΡΩΜΑΤΟΣ ΙΝΟΧ

ΚΩΔ.	ΣΠΕΙΡΩΜΑ A	B mm	Cmm
10.481	1/2"	61	34
10.482	3/4"	71	40
10.483	1"	74	48
10.484	1-1/4"	80	59
10.485	1-1/2"	86	68
10.486	2"	110	93

ΥΔΡΟΡΡΟΗ ΣΠΕΙΡΩΜΑΤΟΣ ΠΛΑΣΤΙΚΗ

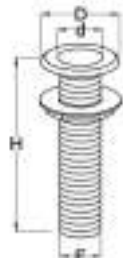

ΚΩΔΙΚΟΣ	H	D	d	F
10.421	65	35	13	1/2"
10.422	65	40	17	3/4"
10.423	65	52	25	1"
10.424	85	65	31	1' 1/4
10.425	85	70	35	1" 1/2



ΕΙΣΑΓΩΓΗ ΝΕΡΟΥ ΙΝΟΧ

ΚΩΔ.	ΣΠΕΙΡΩΜΑ
10.392	1/2"
10.393	3/4"
10.394	1"
10.395	1" 1/4
10.396	1" 1/2
10.397	2"



ΡΑΚΟΡ ΓΩΝΙΑΚΟ ΙΝΟΧ

ΚΩΔ.	ΣΠΕΙΡΩΜΑ
97.162	1/2"
97.163	3/4"
97.164	1"
97.165	1-1/4"
97.166	1-1/2"
97.167	2"



ΡΑΚΟΡ ΒΑΛΒΙΔΑΣ ΙΝΟΧ SS316

ΚΩΔ.	ΔΙΑΣΤΑΣΕΙΣ
13.300	1/2" x 13mm
13.301	3/4" x 20mm
13.302	3/4" x 25mm
13.303	1" x 25mm
13.304	1" x 30mm
13.306	1"1/4 x 38mm
13.307	1"1/2 x 38mm
13.308	2" x 50mm



ΒΑΛΒΙΔΑ ΙΝΟΧ SS316

ΚΩΔ.	ΣΠΕΙΡΩΜΑ
97.141	1/2"
97.142	3/4"
97.144	1"
97.145	1" 1/4
97.146	1" 1/2
97.147	2"



ΡΑΚΟΡ ΙΝΟΧ 90° ΘΗΛΥΚΟ-ΘΗΛΥΚΟ

ΚΩΔ.	ΔΙΑΣΤΑΣΗ
97.170	1/2"
97.171	3/4"
97.172	1"
97.173	1" 1/4 1/4
97.174	1"1/2
97.175	2"

NEW



ΚΟΛΛΑΡΟ ΒΑΛΒΙΔΑΣ

97.031	1/2"	3/4"	1"
97.032	1"	1 1/4"	1" 1/2
97.033	2"		

NEW



97.007 ΚΛΕΙΔΙ ΤΟΠΟΘΕΤΗΣΗΣ ΥΔΡΟΡΡΟΗΣ TRUDESIGN



ΒΑΛΒΙΔΕΣ ΝΕΡΟΥ
TRUDESIGN PVC

ΚΩΔ.	ΔΙΑΣΤ.
97.001	1/2"
97.002	3/4"
97.003	1"
97.004	1 1/4"
97.005	1 1/2"
97.006	2"



ΡΑΚΟΡ ΓΩΝΙΑΚΟ TRUDESIGN

ΚΩΔ.	ΣΠΕΙΡΩΜΑ	ΡΑΚΟΡ Φmm
93.350	1/2"	13
93.351	3/4"	19
93.352	1"	25
93.353	1" 1/4"	32
93.354	1" 1/4"	38
93.355	1" 1/2"	38
93.356	2"	50



ΡΑΚΟΡ ΒΑΛΒΙΔΑΣ TRUDESIGN

ΚΩΔ.	ΣΠΕΙΡΩΜΑ	ΡΑΚΟΡ Φmm
93.380	1/2"	13
93.381	1/2"	16
93.382	3/4"	19
93.383	1"	25
93.384	1" 1/4"	32
93.385	1" 1/4"	38
93.386	1" 1/2"	38
93.387	2"	50



ΡΑΚΟΡ ΒΑΛΒΙΔΑΣ

ΚΩΔ.	ΔΙΑΣΤ.	mm
93.388	1"	25
93.389	1 1/4"	32
93.390	1 1/4"	38
93.395	1 1/2"	38
93.396	2"	50



ΡΑΚΟΡ TRUDESIGN ΘΗΛ

ΚΩΔ.	ΔΙΑΣΤ.	Cmm
93.397	3/4"	19
93.398	1"	25
93.399	1 1/4"	32
93.400	1 1/4"	38
93.401	1 1/2"	32
93.402	1 1/2"	38
93.403	2"	50



ΡΑΚΟΡ ΒΑΛΒΙΔΑΣ ΓΩΝΙΑ
TRUDESIGN ΑΡΣ-ΘΗΛ

ΚΩΔ.	ΔΙΑΣΤ.
93.404	3/4"
93.405	1"
93.406	1 1/4"
93.407	1 1/2"
93.408	2"
93.409	3"



ΥΔΡΟΡΟΗ ΣΠΕΙΡΩΜΑΤΟΣ
TRUDESIGN

ΚΩΔ.	ΣΠΕΙΡΩΜΑ
93.357	1/2"
93.358	3/4"
93.359	1"
93.360	1" 1/4"
93.365	1" 1/2"
93.366	2"
93.367	3"



ΕΡΓΑΛΕΙΟ ΤΟΠΟΘΕΤΗΣΗΣ
ΥΔΡΟΡΟΗΣ TRUDESIGN

ΚΩΔΙΚΟΣ	ΔΙΑΣΤ.
93.410	3/4"
93.411	1"
93.412	1 1/4"
93.413	1 1/2"
93.414	2"



ΚΛΕΙΔΙ ΒΑΛΒΙΔΑΣ
TRUDESIGN

ΚΩΔΙΚΟΣ	ΔΙΑΣΤ.
97.016	1/2"
97.017	3/4"-1"
97.018	1 1/4"-1 1/2"
97.019	2"



ΡΑΚΟΡ ΣΩΛΗΝΑ "Υ"

ΚΩΔΙΚΟΣ	ΔΙΑΣΤ.
94.201	3/4"
94.202	1"
94.203	1 1/2"
94.204	1"-3/4"-3/4"



ΥΔΡΟΡΡΟΗ ΑΝΕΠΙΣΤΡΟΦΗ ΠΛΑΣΤΙΚΗ
98.156 Φ38mm L166mm
98.158 Φ52mm L122mm



10.339
 ΥΔΡΟΡΡΟΗ Φ40mm
 ΓΙΑ ΣΩΛΗΝΑ Φ45mm



10.351
 ΥΔΡΟΡΡΟΗ Φ25mm x L100mm
 A: ΛΕΥΚΟ - B: ΜΑΥΡΟ



10.352
 ΥΔΡΟΡΡΟΗ Φ25mm x L62mm
 A: ΛΕΥΚΟ - B: ΜΑΥΡΟ



10.353
 ΥΔΡΟΡΡΟΗ Φ25mm x L155mm
 A: ΛΕΥΚΟ - B: ΜΑΥΡΟ



10.342
 ΥΔΡΟΡΡΟΗ ΤΗΛΕΣΚΟΠΙΚΗ Φ40mm



98.157
 ΥΔΡΟΡΡΟΗ ΑΝΕΠΙΣΤΡΟΦΗ INOX 38mm L135mm



10.340
 ΤΑΠΑ-ΑΝΕΠΙΣΤΡΟΦΗ ΒΑΛΒΙΔΑ Φ25mm



10.341
 ΑΝΕΠΙΣΤΡΟΦΗ ΒΑΛΒΙΔΑ Φ40mm



ΥΔΡΟΡΡΟΗ ΓΙΑ ΣΩΛΗΝΑ TRUDESIGN

ΚΩΔ.	ΛΕΥΚΟ	ΜΑΥΡΟ	ΣΠΕΙΡ	CONNECTOR ØØ
93.421	A	B	1/2"¼	13 mm
93.422	A	B	3/4"¼	19 mm
93.423	A	B	1"¼	25 mm
93.424	A	B	1"1/4	32 mm
93.425	A	B	1"1/2	38 mm
93.426	A	B	2"¼	50 mm



ΥΔΡΟΡΡΟΗ MINI

ΚΩΔΙΚΟΣ	Φ mm
10.461	10
10.462	13
10.463	16
10.464	20
10.465	25
10.466	30



ΥΔΡΟΡΡΟΗ ΜΕ INOX ΚΑΠΑΚΙ

ΚΩΔ.	A	B	C	D	E	d1
10.333	16	48	80	1"	50	22
10.334	19	48	80	1"	50	22
10.335	25	48	80	1"	50	22
10.336	30	48	80	1"	50	22
10.337	38	60	95	1"1/4	50	28
10.338	50	82,5	118	2"	63	47



10.670
 ΦΙΛΤΡΟ ΣΕΝΤΙΝΑΣ ΜΠΡΟΥΤΖΙΝΟ Φ19mm ΟΡΙΖΟΝΤΙΟ

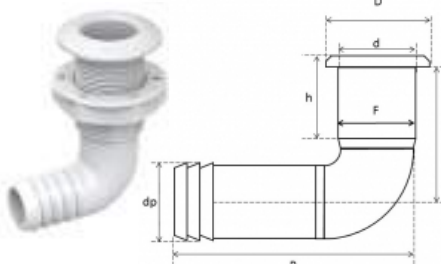

ΥΔΡΟΡΡΟΗ ΓΙΑ ΣΩΛΗΝΑ ΓΩΝΙΑ

ΚΩΔ.	H	D	d	dp	p	F
10.343	79	47	18	20	63	3/4"
10.344	84	54	25	25	70	1"
10.345	110	68	35	38	80	1" 1/2



10.677
 ΦΙΛΤΡΟ ΣΕΝΤΙΝΑΣ ΜΠΡΟΥΤΖΙΝΟ Φ19mm ΚΑΘΕΤΟ

ΥΔΡΟΡΡΟΗ ΓΙΑ ΣΩΛΗΝΑ



ΚΩΔ.	H	D	d	d1	dp	F
10.347	94	35	10	13	15	1/2"
10.348	94	40	12	17	20	3/4"
10.349	94	52	18	24	25	1"
10.358	94	65	23	31	35	1 1/4"
10.354	94	70	31	35	38	1 1/2"



ΥΔΡΟΡΡΟΗ ΓΩΝΙΑΚΗ ΙΝΟΧ



ΚΩΔ.	A mm	B mm	C mm	D mm	E-Max. mm
10.365	19 (3/4")	62 (2-7/16")	32 (1-1/4")	43 (1-11/16")	19 (3/4")
10.366	25 (1")	65 (2-9/16")	32 (1-1/4")	43 (1-11/16")	19 (3/4")
10.367	29 (1-1/8")	67 (2-5/8")	32 (1-1/4")	43 (1-11/16")	19 (3/4")
10.368	38 (1-1/2")	82 (3-1/4")	41 (1-5/8")	59 (2-5/16")	21 (13/16")

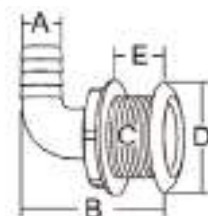

ΥΔΡΟΡΡΟΗ ΙΝΟΧ ΓΙΑ ΣΩΛΗΝΑ



ΚΩΔ.	A mm	B mm	C mm	D mm	E-Max. mm
10.382	19 (3/4")	70.5 (2-3/4")	32 (1-1/4")	43 (1-11/16")	31 (1-3/16")
10.383	25 (1")	70.5 (2-3/4")	32 (1-1/4")	43 (1-11/16")	31 (1-3/16")
10.384	29 (1-1/8")	70.5 (2-3/4")	32 (1-1/4")	43 (1-11/18")	31 (1-3/16")
10.385	38 (1-1/2")	80 (3-3/16")	45 (1-3/4")	65 (2-9/16")	32 (1-5/16")

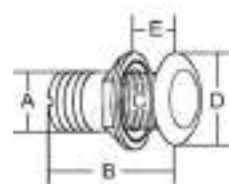

ΥΔΡΟΡΡΟΗ ΓΩΝΙΑΚΗ ΜΕ ΙΝΟΧ ΚΑΠΑΚΙ



ΚΩΔΙΚΟΣ	A (mm)	B (mm)	C (mm)	D (mm)	E (mm)	F (mm)	d1
10.386	16	48	73	1"	50	64	22
10.387	19	48	73	1"	50	64	22
10.388	25	48	76	1"	50	64	22
10.389	30	48	76	1"	50	31	22
10.390	38	60	88	1 1/4"	50	96	28

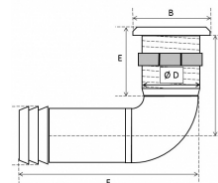

ΥΔΡΟΡΡΟΗ ΙΣΙΑ ΜΕ ΙΝΟΧ ΚΑΠΑΚΙ ΚΑΙ ΑΝΕΠΙΣΤΡΟΦΗ



ΚΩΔΙΚΟΣ	A (mm)	B (mm)	C (mm)	D (mm)	E (mm)	d1
10.410	25	48	80	1"	50	22
10.411	38	60	95	1 1/4"	50	28
10.412	50	82,5	118	2"	63	47

ΥΔΡΟΡΡΟΗ ΙΣΙΑ ΑΝΕΠΙΣΤΡΟΦΗ



ΚΩΔΙΚΟΣ	Size	A (mm)	B(mm)	C(mm)	D(")	E(mm)	d1(mm)
10.442	3/4"	19	48	85	1"	52	24.5
10.443	1"	25	48	85	1"	52	24.5
10.444	1 1/2"	38	60	95	1 1/4"	55	32
10.445	2"	51	82.5	130	2"	80	49



ΥΔΡΟΡΡΟΗ ΓΩΝΙΑΚΗ ΑΝΕΠΙΣΤΡΟΦΗ

ΚΩΔΙΚΟΣ	Size	A (mm)	B(mm)	C(mm)	D(")	E(mm)	d1(mm)
10.446	3/4"	19	48	85	1"	52	24.5
10.447	1"	25	48	85	1"	52	24.5
10.448	1 1/2"	38	60	95	1 1/4"	55	32



10.903
ΤΑΠΑ ΛΑΣΤΙΧΟ Φ22,5mm



10.918
ΤΑΠΑ ΛΑΣΤΙΧΟ Φ25mm



10.502
ΤΑΠΑ ΛΑΣΤΙΧΟ Φ35mm



10.905
ΤΑΠΑ ΛΑΣΤΙΧΟ Φ40mm



ΤΑΠΑ ΠΕΤΑΛΟΥΔΑ
25.021 ΜΙΚΡΗ
25.023 ΜΕΓΑΛΗ



ΤΑΠΑ ΣΤΕΓΑΝΩΝ ΝΑΥΛΟΝ
25.024 ΚΟΜΠΛΕ ΑΡΣ.-ΘΗΛ.
25.025 ΑΡΣΕΝΙΚΗ



ΤΑΠΑ ΣΤΕΓΑΝΩΝ
INOX ΚΟΜΠΛΕ
25.026 Φ25mm
25.027 Φ30mm

ΑΝΤΛΙΕΣ ΛΥΜΑΤΩΝ

ΥΔΡΑΥΛΙΚΟΣ ΕΞΟΠΛΙΣΜΟΣ

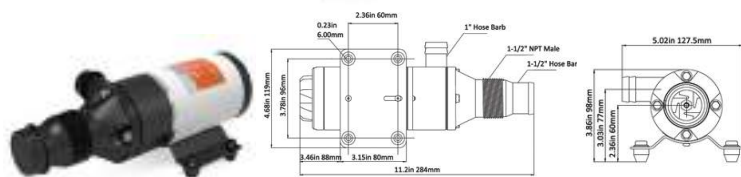

16.530 - ΑΝΤΛΙΑ ΛΥΜΑΤΩΝ MACERATOR 12V
16.550 - ΑΝΤΛΙΑ ΛΥΜΑΤΩΝ MACERATOR 24V



16.301A - ΑΝΤΛΙΑ ΑΚΑΘΑΡΤΩΝ 12V 38/19mm
16.301B - ΑΝΤΛΙΑ ΑΚΑΘΑΡΤΩΝ 24V 38/19mm



ΑΝΤΛΙΑ ΑΚΑΘΑΡΤΩΝ

ΚΩΔ.	V/lpm	Ømm	Ømm
16.201A	12/19	38	
16.202A	24/19	38	
16.201B	12/19		25
16.202B	24/19		25



ΑΝΤΛΙΑ ΑΚΑΘΑΡΤΩΝ

ΚΩΔ.	V/lpm	Ømm	Ømm
16.203A	12/19	38	
16.204A	24/19	38	
16.203B	12/19		19
16.204B	24/19		19



16.071 - ΑΝΤΛΙΑ ΛΥΜΑΤΩΝ MACERATOR 12V
16.069 - ΑΝΤΛΙΑ ΛΥΜΑΤΩΝ MACERATOR 24V



16.181A ΑΝΤΛΙΑ ΛΥΜΑΤΩΝ GULPER 220 12V
16.181B ΑΝΤΛΙΑ ΛΥΜΑΤΩΝ GULPER 220 24V

NEW



16.182A ΑΝΤΛΙΑ ΑΚΑΘΑΡΤΩΝ GULPER 320 12V
16.182B ΑΝΤΛΙΑ ΑΚΑΘΑΡΤΩΝ GULPER 320 24V

NEW



16.206 - ΡΑΚΟΡ ΑΝΤ/ΚΟ 19mm ΑΝΤΛ. ΑΚΑΘ.
16.207 - ΡΑΚΟΡ ΑΝΤ/ΚΟ 38mm ΑΝΤΛ. ΑΚΑΘ.



16.205
ΒΑΛΒΙΔΑ ΑΝΤΑΛ/ΚΗ
ΑΝΤΛΙΑΣ ΑΚΑΘΑΡΤΩΝ



16.070 - ΑΝΤΛΙΑ ΛΥΜΑΤΩΝ MACERATOR 12V
16.072 - ΑΝΤΛΙΑ ΛΥΜΑΤΩΝ MACERATOR 24V



ΟΡΓΑΝΟ ΜΕΤΡΗΣΗΣ ΤΡΙΩΝ
ΕΠΙΠΕΔΩΝ ΑΚΑΘΑΡΤΩΝ
11.633A ΛΕΥΚΟ
11.633B ΜΑΥΡΟ



90.073
ΜΕΤΡΗΤΗΣ ΗΛΕΚΤΡΙΚΟΣ
ΑΚΑΘΑΡΤΩΝ



11.637
ΟΡΓΑΝΟ ΑΚΑΘΑΡΤΩΝ
240/33 Ω ΛΕΥΚΟ



11.638
ΟΡΓΑΝΟ ΑΚΑΘΑΡΤΩΝ
240/33 Ω ΜΑΥΡΟ



96.454
ΦΩΤΑΚΙ
ΠΡΟΕΙΔΟΠΟΙΗΤΙΚΟ
ΚΟΚΚΙΝΟ



90.075
ΜΕΤΡΗΤΗΣ ΑΚΑΘΑΡΤΩΝ
ΕΝΔΕΙΞΗΣ ΠΛΗΡΩΣΗΣ 1 1/4"



90.079
ΜΕΤΡΗΤΗΣ ΚΑΙ ΟΡΓΑΝΟ
ΑΚΑΘΑΡΤΩΝ 15-40cm



ΜΕΤΡΗΤΗΣ ΑΚΑΘΑΡΤΩΝ
ΜΕ ΣΠΕΙΡΩΜΑ 240-33Ω
90.077 H.185 mm
90.078 H.280 mm
90.080 H.380 mm



ΜΕΤΡΗΤΗΣ ΑΚΑΘΑΡΤΩΝ
240-33Ω 5 ΤΡΥΠΕΣ
90.177 185mm
90.178 280mm
90.180 380mm



ΒΑΛΒΙΔΑ ΤΡΙΟΔΗ
90.072 Φ25mm
90.074 Φ38mm



ΣΙΦΩΝΙ ΚΟΝΕΚΤΟΡΑΣ
95.066 25mm
95.067 38mm



95.073
ΒΑΛΒΙΔΑ TRUDESIGN
ΔΙΑΧΩΡΙΣΤΗΣ 3 ΘΕΣΕΩΝ



ΡΟΥΞΟΥΝΙ TRUDESIGN
ΓΙΑ ΒΑΛΒΙΔΑ 95.073
95.081 Φ 38mm 120°
95.085 Φ 25mm 120°



ΡΟΥΞΟΥΝΙ TRUDESIGN
ΓΙΑ ΒΑΛΒΙΔΑ 95.073
95.086 Φ 38mm 90°
95.087 Φ 25mm 90°



98.067
ΦΙΛΤΡΟ ΛΥΜΑΤΩΝ
ΑΝΘΡΑΚΑ
Φ19-25mm



98.068
ΑΝΤΑΛΑΚΤΙΚΟ
ΦΙΛΤΡΟ ΑΝΘΡΑΚΑ
ΓΙΑ 98.067



98.064
ΦΙΛΤΡΟ ΑΝΘΡΑΚΑ
ΓΙΑ ΛΥΜΑΤΑ



95.072
ΣΙΦΩΝΙ ΚΟΝΕΚΤΟΡΑΣ
Φ 13 έως 38mm



90.071
ΒΑΛΒΙΔΑ ΤΡΙΟΔΗ ΙΤΑΛΙΑΣ
25mm-38mm

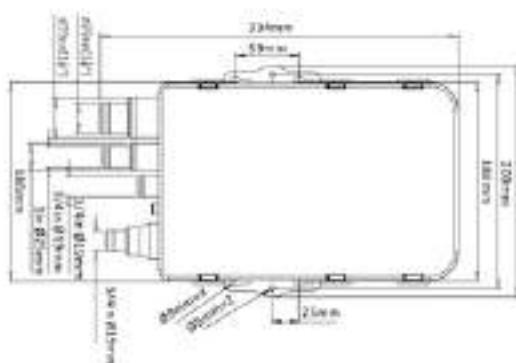

ΣΥΣΤΗΜΑ ΑΠΟΡΡΟΗΣ ΥΔΑΤΩΝ
ΜΕ ΑΝΤΛΙΑ ΑΥΤΟΜΑΤΗ

99.900 600GRH 12V
99.901 750GRH 12V
99.902 750GRH 24V



ΝΤΕΠΟΖΙΤΟ ΑΚΑΘΑΡΤΩΝ ΜΕ ΑΝΤΛΙΑ ΛΥΜΑΤΩΝ*

ΚΩΔΙΚΟΣ	ΧΩΡΗΤ/ΤΑ Lt	ΜΗΚΟΣ mm	ΥΨΟΣ mm	ΠΛΑΤΟΣ mm
10.961	35	550	200	390
10.962	41	650	200	390
10.963	48	750	200	390
10.964	54	850	200	390
10.965	61	950	200	390
10.966	67	1050	200	390
10.967	53	550	290	390
10.968	63	650	290	390
10.969	73	750	290	390
10.972	83	850	290	390
10.973	93	950	290	390
10.974	103	1050	290	390

*ΠΕΡΙΕΧΕΙ: ΦΙΛΤΡΟ ΑΝΘΡΑΚΑ, ΜΕΤΡΗΤΗ, ΣΙΦΟΝΙ, ΕΞΑΕΡΙΣΤΙΚΟ

ΝΤΕΠΟΖΙΤΟ ΑΚΑΘΑΡΤΩΝ

ΚΩΔΙΚΟΣ	ΧΩΡΗΤ/ΤΑ Lt	ΜΗΚΟΣ mm	ΥΨΟΣ mm	ΠΛΑΤΟΣ mm
11.100	28	450	200	390
11.101	35	550	200	390
11.102	41	650	200	390
11.103	48	750	200	390
11.104	54	850	200	390
11.105	61	950	200	390
11.106	67	1050	200	390
11.107	43	450	290	390
11.108	53	550	290	390
11.109	63	650	290	390
11.110	73	750	290	390
11.111	83	850	290	390
11.112	93	950	290	390
11.113	103	1050	290	390

ΝΤΕΠΟΖΙΤΟ ΑΚΑΘΑΡΤΩΝ ΟΡΘΙΑΣ ΤΟΠΟΘΕΤΗΣΗΣ



ΚΩΔΙΚΟΣ	ΧΩΡΗΤ/ΤΑ Lt	ΜΗΚΟΣ mm	ΥΨΟΣ mm	ΠΛΑΤΟΣ mm
11.211	41	200	650	390
11.212	48	200	750	390
11.213	54	200	850	390
11.214	61	200	950	390
11.215	67	200	1050	390
11.216	63	290	650	390
11.217	73	290	750	390
11.218	83	290	850	390
11.219	93	290	950	390
11.220	103	290	1050	390



ΝΤΕΠΟΖΙΤΟ ΑΚΑΘΑΡΤΩΝ ΜΑΥΡΟ 50lt

ΚΩΔΙΚΟΣ	ΜΗΚΟΣ (mm)	ΥΨΟΣ(mm)	ΠΛΑΤΟΣ(mm)
11.238	600	330	330



97.129
ΦΛΑΤΖΑ ΔΕΞΑΜΕΝΗΣ ΑΚΑΘΑΡΤΩΝ



98.066
ΚΙΤ ΑΞΕΣΟΥΑΡ-ΡΑΚΟΡ
ΓΙΑ ΝΤΕΠΟΖΙΤΟ ΑΚΑΘΑΡΤΩΝ



98.163
ΣΩΛΗΝΑ ΑΚΑΘΑΡΤΩΝ
Φ 38mm

ΤΟΥΑΛΕΤΑ ΧΕΙΡΟΚΙΝΗΤΗ

ΥΔΡΑΥΛΙΚΟΣ ΕΞΟΠΛΙΣΜΟΣ



10L

15.290 ΤΟΥΑΛΕΤΑ ΧΗΜΙΚΗ 10 lt
15.291 ΤΟΥΑΛΕΤΑ ΧΗΜΙΚΗ 20 lt



20L



15.292
ΤΟΥΑΛΕΤΑ ΧΗΜΙΚΗ NT 18lt

SEAFLO



15.286
ΤΟΥΑΛΕΤΑ ΧΕΙΡΟΚΙΝΗΤΗ
ΜΙΚΡΗ ΛΕΚΑΝΗ

OSCULATI



ΤΟΥΑΛΕΤΑ ΧΕΙΡΟΚΙΝΗΤΗ
15.219 COMPACT ΜΙΚΡΗ ΛΕΚΑΝΗ
15.209 COMFORT ΜΕΓΑΛΗ ΛΕΚΑΝΗ



15.321
ΒΙΟΡΑΚ ΧΗΜΙΚΗΣ ΤΟΥΑΛΕΤΑΣ



15.215
ΑΝΤΑΛ/ΚΟ ΣΕΤ
ΧΕΙΡΟΚΙΝΗΤΗΣ ΤΟΥΑΛΕΤΑΣ ΙΤΑΛΙΑΣ



15.299
ΒΑΣΗ ΤΟΥΑΛΕΤΑΣ
ΧΕΙΡΟΚΙΝΗΤΗΣ SEAFLO



15.289
ΑΝΤΛΙΑ ΧΕΙΡΟΚΙΝΗΤΗΣ
ΤΟΥΑΛΕΤΑΣ NT



15.216
ΚΙΤ ΒΑΣΗ+ΑΝΤΛΙΑ ΧΕΙΡΟΚΙΝΗΤΗΣ
ΤΟΥΑΛΕΤΑΣ ΙΤΑΛΙΑΣ



TMD

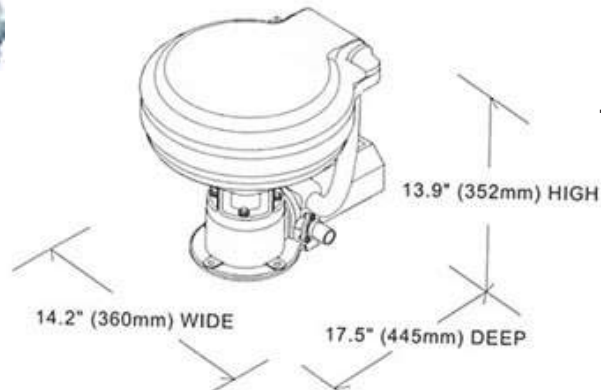

ΤΟΥΑΛΕΤΑ ΗΛΕΚΤΡΙΚΗ ΜΙΚΡΗ

15.221 12V

15.222 24V



TMD



15.225

ΤΟΥΑΛΕΤΑ ΗΛΕΚΤΡΙΚΗ DELUXE 12V
(ΜΕΓΑΛΗ ΛΕΚΑΝΗ)

15.247

ΤΟΥΑΛΕΤΑ ΗΛΕΚΤΡΙΚΗ DELUXE 24V
(ΜΕΓΑΛΗ ΛΕΚΑΝΗ)

SEAFLO

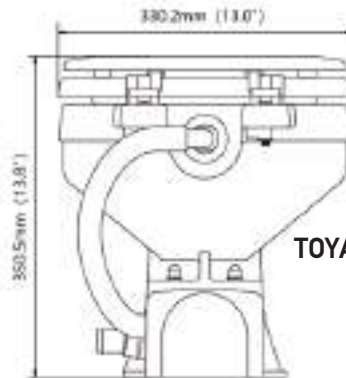

ΤΟΥΑΛΕΤΑ ΗΛΕΚΤΡΙΚΗ
ΜΙΚΡΗ

15.293A 12V

15.293B 24V

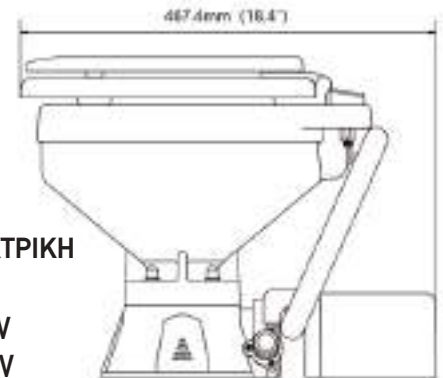

SEAFLO

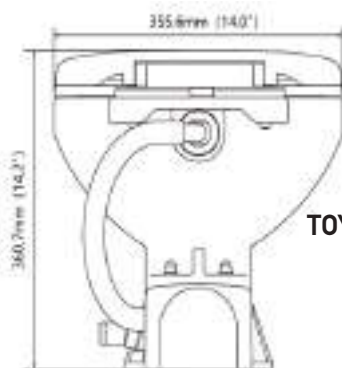

ΤΟΥΑΛΕΤΑ ΗΛΕΚΤΡΙΚΗ
ΜΕΓΑΛΗ

15.294A 12V

15.294B 24V

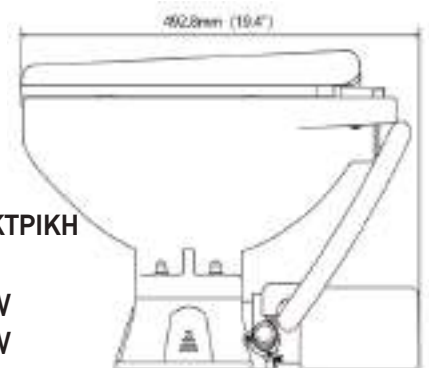

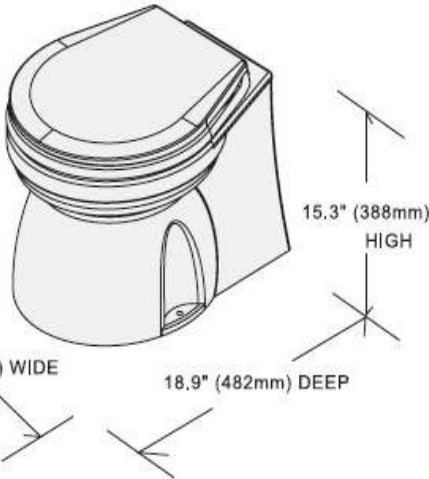

**ΤΟΥΑΛΕΤΑ ΚΛΕΙΣΤΗ
DELUXE**

- 15.280** 12V
- 15.281** 24V



ΤΟΥΑΛΕΤΑ ΗΛΕΚΤΡΙΚΗ ΙΤΑΛΙΑΣ

- 15.200** 12V COMFORT ΜΕΓΑΛΗ ΛΕΚΑΝΗ
- 15.199** 24V COMFORT ΜΕΓΑΛΗ ΛΕΚΑΝΗ
W37 X D46 X H39



- 15.298A** ΤΟΥΑΛΕΤΑ ΗΛΕΚΤΡΙΚΗ
ΑΘΟΥΡΥΒΗ SLIM 12V
- 15.298B** ΤΟΥΑΛΕΤΑ ΗΛΕΚΤΡΙΚΗ
ΑΘΟΥΡΥΒΗ SLIM 24 V



ΤΟΥΑΛΕΤΑ ΗΛΕΚΤΡΙΚΗ ΙΤΑΛΙΑΣ

- 15.223** 12V COMPACT ΜΙΚΡΗ ΛΕΚΑΝΗ
- 15.224** 24V COMPACT ΜΙΚΡΗ ΛΕΚΑΝΗ
W34 X D42 X H39

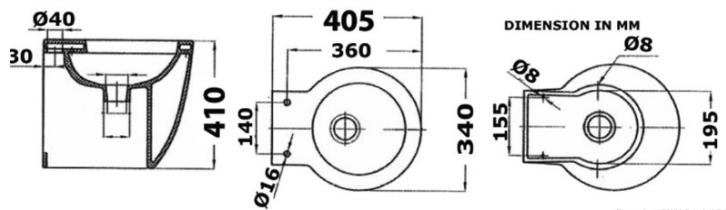

- ΤΟΥΑΛΕΤΑ ΗΛΕΚΤΡΙΚΗ
SEAFLO N.T.**
- 15.287A** 12V
 - 15.287B** 24V

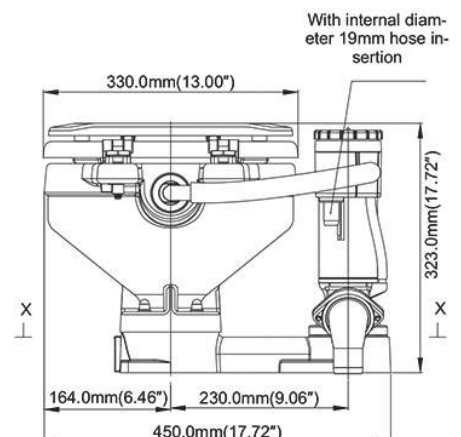
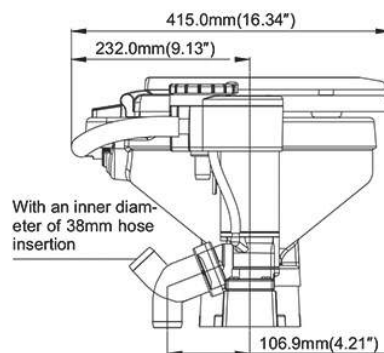



15.282 - ΚΙΤ ΜΕΤΑΤΡΟΠΗΣ ΚΛΕΙΣΤΗΣ ΤΟΥΑΛΕΤΑΣ 12V
15.283 - ΚΙΤ ΜΕΤΑΤΡΟΠΗΣ ΚΛΕΙΣΤΗΣ ΤΟΥΑΛΕΤΑΣ 24V



15.231 - ΚΙΤ ΜΕΤΑΤΡΟΠΗΣ ΗΛΕΚΤΡΙΚΗΣ ΤΟΥΑΛΕΤΑΣ 12V
15.232 - ΚΙΤ ΜΕΤΑΤΡΟΠΗΣ ΗΛΕΚΤΡΙΚΗΣ ΤΟΥΑΛΕΤΑΣ 24V



15.229 - ΚΙΤ ΗΛΕΚΤΡΙΚΗΣ ΤΟΥΑΛΕΤΑΣ 12 V ΙΤΑΛΙΑΣ
15.230 - ΚΙΤ ΗΛΕΚΤΡΙΚΗΣ ΤΟΥΑΛΕΤΑΣ 24V ΙΤΑΛΙΑΣ



15.285A - ΚΙΤ ΗΛΕΚΤΡΙΚΗΣ ΤΟΥΑΛΕΤΑΣ ΜΕ ΠΑΝΕΛ 12V
15.285B - ΚΙΤ ΗΛΕΚΤΡΙΚΗΣ ΤΟΥΑΛΕΤΑΣ ΜΕ ΠΑΝΕΛ 24V



15.233 - ΜΟΤΕΡ ΗΛ. ΤΟΥΑΛΕΤΑΣ 12V
15.234 - ΜΟΤΕΡ ΗΛ. ΤΟΥΑΛΕΤΑΣ 24V



15.310 - ΚΙΤ ΤΟΥΑΛΕΤΑΣ EVOLUTION 12V ΜΤ
15.311 - ΚΙΤ ΤΟΥΑΛΕΤΑΣ EVOLUTION 24V ΜΤ



15.236 - ΚΙΤ ΗΛ. ΤΟΥΑΛΕΤΑΣ 12V ΧΩΡΙΣ ΜΠΟΥΤΟΝ
15.255 - ΚΙΤ ΗΛ. ΤΟΥΑΛΕΤΑΣ 24V ΧΩΡΙΣ ΜΠΟΥΤΟΝ



15.312 - ΚΙΤ ΤΟΥΑΛΕΤΑΣ ΙΤΑΛΙΑΣ (ΜΟΤΕΡ)



16.224 - ΑΝΤ/ΚΟ ΣΕΤ ΕΙΣΑΓΩΓΗΣ ΝΕΡΟΥ
Ø25



16.222 - ΑΝΤ/ΚΟ ΣΕΤ ΕΞΑΓΩΓΗΣ



16.223 - ΑΝΤ/ΚΗ ΦΛΑΤΖΑ ΒΑΣΗΣ ΜΕ ΒΙΔΕΣ



16.231 - ΑΝΤ/ΚΟ ΜΑΧΑΙΡΙ ΜΕ ΦΛΑΤΖΑ

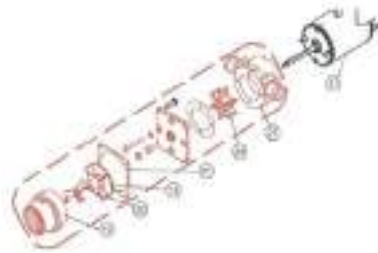

16.233 - ΑΝΤ/ΚΟ ΚΙΤ ΙΜΠΕΛΕΡ,
ΦΛΑΤΖΑ ΚΑΙ ΣΩΜΑ ΑΝΤΛΙΑΣ

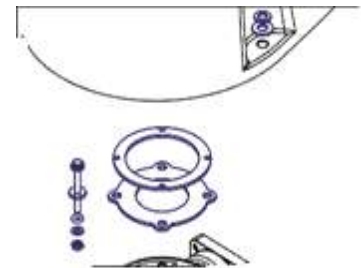

16.240 - ΑΝΤΑΛΛΑΚΤΙΚΗ ΦΛΑΤΖΑ
ΚΛΕΙΣΤΗΣ ΤΟΥΑΛΕΤΑΣ



16.220 - ΑΝΤ/ΚΟ ΣΕΤ ΓΙΑ ΚΑΘΙΣΜΑ
ΜΙΚΡΟ ΤΟΥΛΕΤΑΣ SOFT CLOSE



16.221 - ΑΝΤ/ΚΟ ΣΕΤ ΓΙΑ
ΚΑΘΙΣΜΑ ΜΕΓΑΛΟ ΤΟΥΛΕΤΑΣ
SOFT CLOSE



16.239 - ΑΝΤΑΛΛΑΚΤΙΚΟ ΕΙΣΑΓΩΓΗΣ
ΚΛΕΙΣΤΗΣ ΤΟΥΛΕΤΑΣ



16.225
ΑΝΤ/ΚΟ ΦΥΓΟΚΕΝΤΡΟ
ΙΜΠΕΛΕΡ
ΗΛΕΚΤΡΙΚΗΣ ΤΟΥΛΕΤΑΣ



16.228
ΑΝΤΑΛΛΑΚΤΙΚΟ
ΕΙΣΑΓΩΓΗΣ Ø20mm



16.227
ΑΝΤΑΛΛΑΚΤΙΚΟ ΣΕΤ
ΕΞΑΓΩΓΗΣ



16.226
ΑΝΤ/ΚΟ ΚΑΠΑΚΙ
MACERATOR ΤΟΥΛΕΤΑΣ



16.524A ΚΙΤ ΤΟΥΑΛΕΤΑΣ SEAFLO 12V
16.524B ΚΙΤ ΤΟΥΑΛΕΤΑΣ SEAFLO 24V



ΚΙΤ ΑΘΟΥΡΒΗΣ ΤΟΥΑΛΕΤΑΣ
QUIET FLUSH
15.240A 12V / 15.240B 24V



15.271
ΑΝΤΑΛΛΑΚΤΙΚΟ ΚΙΤ
ΗΛΕΚΤΡΙΚΗΣ ΤΟΥΑΛΕΤΑΣ



15.272
ΑΝΤΑΛΛΑΚΤΙΚΟ ΣΕΤ
ΗΛΕΚΤΡΙΚΗΣ ΤΟΥΑΛΕΤΑΣ ΙΤΑΛΙΑΣ
MACERATOR GROUP



16.238
ΑΝΤΑΛΛΑΚΤΙΚΟ ΚΑΛΥΜΑ
ΜΟΤΕΡ



ΔΙΑΚΟΠΤΗΣ ΗΛΕΚΤΡΙΚΗΣ
ΤΟΥΑΛΕΤΑΣ

15.226 12V
15.227 24V



16.209
ΔΙΑΚΟΠΤΗΣ ΠΑΝΕΛ ΑΦΗΣ
ΓΙΑ QUIET FLUSH



ΗΛΕΚΤΡΟΒΑΛΒΙΔΑ
ΤΟΥΑΛΕΤΑΣ
15.351 - 12V
15.352 - 24V



16.210
ΔΙΑΚΟΠΤΗΣ (ΠΑΝΕΛ)
ΓΙΑ QUIET FLUSH



ΑΝΤΙΑ ΠΡΕΣΟΣΤΑΤΙΚΗ ΓΙΑ QUIET FLUSH ΤΟΥΑΛΕΤΑ lpm15 50psi
16.208A 12V / **16.208B** 24V

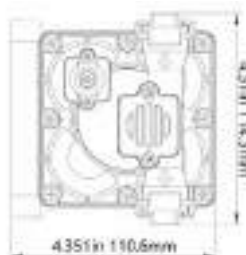

ΚΑΠΑΚΙΑ ΤΟΥΑΛΕΤΑΣ

- 15.212** OCEAN ΞΥΛΙΝΟ
- 15.217** OCEAN (ΜΕΓΑΛΟ) SOFT CLOSE
- 15.218** TMC DELUXE (ΜΕΓΑΛΟ) SOFT CLOSE
- 15.220** TMC DELUXE (ΜΙΚΡΟ) SOFT CLOSE
- 15.239** SEAFLO ΞΥΛΙΝΟ (ΜΙΚΡΟ) SOFT CLOSE
- 15.252** SEAFLO ΞΥΛΙΝΟ (ΜΕΓΑΛΟ) SOFT CLOSE



ΑΝΤΙΑ ΗΛ/ΚΗΣ ΤΟΥΑΛΕΤΑΣ NT
15.288A 12V
15.288B 24V

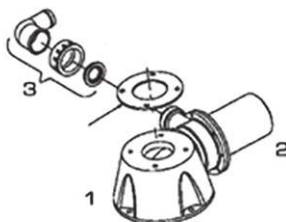

15.273
ΑΝΤΑΛΛΑΚΤΙΚΟ ΕΞΟΔΟ
ΗΛΕΚ.ΤΟΥΑΛΕΤΑΣ ΙΤΑΛΙΑΣ



ΑΝΤΑΛΑΚΤΙΚΑ ΤΟΥΑΛΕΤΑΣ
ΔΙΑΚΟΠΤΗΣ(ΚΑΖΑΝΑΚΙ)
16.232 A - 12V
16.232 B - 24V



15.228 - ΒΑΣΗ ΗΛΕΚ. ΤΟΥΑΛΕΤΑΣ OSCULATI
15.248 - ΒΑΣΗ ΗΛΕΚ. ΤΟΥΑΛΕΤΑΣ TMC



15.238A - ΜΟΤΕΡ QUIET FLUSH 12V
15.238B - ΜΟΤΕΡ QUIET FLUSH 24V



16.528A ΜΟΤΕΡ ΤΟΥΑΛΕΤΑΣ SEAFLO 12V
16.528B ΜΟΤΕΡ ΤΟΥΑΛΕΤΑΣ SEAFLO 24V



15.260

ΡΑΔΙΟ MP3 ΜΕ USB ΘΥΡΑ 4x40W ΑΔΙΑΒΡΟΧΟ

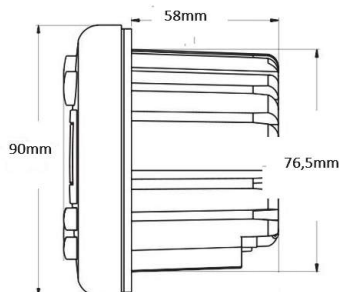

15.278

ΡΑΔΙΟ MP3 ΜΕ TFT 5" ΘΘΟΝΗ L190xW140mm ΜΕ ΘΥΡΑ USB

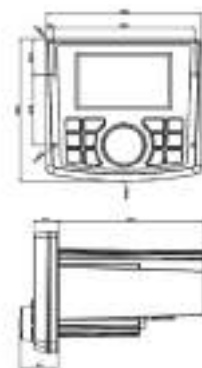

15.262

ΡΑΔΙΟ MP3 3" ΘΘΟΝΗ TFT ΜΕ ΘΥΡΑ USB ΚΑΙ ΣΤΡΟΓΓΥΛΟ ΧΕΙΡΙΣΤΗΡΙΟ



15.276

ΡΑΔΙΟ MP3 ΑΔΙΑΒΡΟΧΟ



15.263

ΡΑΔΙΟ MP3 ΜΕ ΘΥΡΑ USB



15.261

ΡΑΔΙΟ MP3 BT H-327



ΡΑΔΙΟ MP3

15.331 VX565

15.332 VX565DR DAB

- IPx5 Marine Bluetooth Stereo
- 10.8-15.6V DC input, 10 amp 3AG fuse
- 3" IPS TFT Display, full viewing angle
- VIDEO/MP3/WMA playback
- 3 Audio Zone settings
- Bluetooth Audio Streaming
- AM/FM/WB Tuner, 30 preset stations
- Wireless Remote Control
- 4 x 50W built in amplifier
- USB/ 3.5mm AUX input
- Single DIN Mounting Hole: L 136.2 x W 51mm
- Mounting depth: Min 110 mm



15.333

ΡΑΔΙΟ MP3 BT PX158

- IPx5 Marine Bluetooth Stereo
- 10.8-15.6V DC input, 6 amp 3AG fuse
- 3" TFT Crystal Display
- MP3/WMA playback
- Bluetooth Audio Streaming
- AM/FM Tuner, 18 preset stations
- 4x45W built in amplifier
- USB/ 3.5mm AUX input
- 80mm Gauge Mounting with 4 x front screws
- Mounting depth: Min 98 mm



15.266

ΡΑΔΙΟ MP3 BT H-328

Βασικές λειτουργίες:

- FM, AM, USB, BT, AUX IN, RCA OUT
- BLUETOOTH: (10 μέτρα)
- ΕΞΟΔΟΣ: 4 x 40W
- Αδιάβροχο επίπεδο: IP66



15.171

ΠΡΟΣΩΠΗ ΡΑΔΙΟΦΩΝΟΥ ΟΒΑΛ ΙΤΑΛΙΑΣ



15.251

ΠΡΟΣΩΠΗ ΡΑΔΙΟΦΩΝΟΥ ΕΞΩΤΕΡΙΚΗ



15.185

ΠΡΟΣΩΠΗ ΡΑΔΙΟΦΩΝΟΥ ΟΒΑΛ ΜΕ ΚΟΥΜΠΙ



15.259B

ΠΡΙΖΑ ΡΑΔΙΟΦΩΝΟΥ AUX-USB



15.259A

ΠΡΙΖΑ ΡΑΔΙΟΦΩΝΟΥ ΑΔΙΑΒΡΟΧΗ AUX & USB



ΗΧΕΙΑ ΑΔΙΑΒΡΟΧΑ

ΚΩΔ.	Ø Amm	Ø Bmm	D mm	W
15.121	160	125	57	50
15.122	188	144	57	80

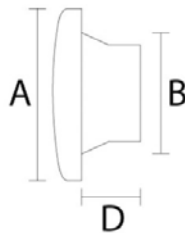

ΗΧΕΙΑ ΑΔΙΑΒΡΟΧΑ RGB MULTICOLOUR

ΛΕΥΚΟ	ΜΑΥΡΟ	Ø Amm	Ø Bmm	D mm	W
15.301A	15.301B	5,25"	125	57	80
15.302A	15.302B	6,25"	144	57	120



ΗΧΕΙΑ ΑΔΙΑΒΡΟΧΑ

ΚΩΔ	ΤΥΠΟΣ	Amm	Bmm	D mm	WATT	ΧΡΩΜΑ
15.304A	5,25"	166	121	83	2x80	ΛΕΥΚΟ
15.304B	5,25"	166	121	83	2x80	ΜΑΥΡΟ
15.305A	6,5"	192	138	98	2x120	ΛΕΥΚΟ
15.305B	6,5"	192	138	98	2x120	ΜΑΥΡΟ
15.306A	8,0"	232	184	124	2x180	ΛΕΥΚΟ
15.306B	8,0"	232	184	124	2x180	ΜΑΥΡΟ



ΗΧΕΙΑ ΑΔΙΑΒΡΟΧΑ



ΚΩΔΙΚΟΣ	ΤΥΠΟΣ	Amm	Bmm	Dmm	WATT(ζευγος)	ΧΡΩΜΑ
15.243	5,25"	147	114	54	80	ΛΕΥΚΟ
15.244	6,5"	180	135	63	120	ΛΕΥΚΟ



ΗΧΕΙΑ ΣΤΕΝΑ



ΚΩΔΙΚΟΣ	ΤΥΠΟΣ	Amm	Bmm	Dmm	WATT(ζευγος)	ΧΡΩΜΑ
15.246	5,25"	150	120	23	60	ΛΕΥΚΟ



ΗΧΕΙΑ RGB

ΚΩΔ	ΤΥΠΟΣ	Amm	Bmm	D mm	WATT	ΧΡΩΜΑ
15.361A	5,25"	166	121	57	100	ΛΕΥΚΟ
15.361B	5,25"	166	121	57	100	ΜΑΥΡΟ
15.361C	5,25"	166	121	57	100	ΓΚΡΙ
15.362A	6,5"	193	149	68	150	ΛΕΥΚΟ
15.362B	6,5"	193	149	68	150	ΜΑΥΡΟ
15.362C	6,5"	193	149	68	150	ΓΚΡΙ



ΗΧΕΙΑ ΣΤΕΝΑ



ΚΩΔΙΚΟΣ	ΤΥΠΟΣ	Amm	Bmm	Dmm	WATT(ζευγος)	ΧΡΩΜΑ
15.303A	5,25"	162,5	119	23	40	ΛΕΥΚΟ
15.303B	5,25"	162,5	119	23	40	ΜΑΥΡΟ
15.341A	6,5"	186	135	23,5	60	ΛΕΥΚΟ
15.341B	6,5"	186	135	23,5	60	ΜΑΥΡΟ



ΕΝΙΣΧΥΤΗΣ ΗΧΟΥ BT

15.355 6x30W
15.356 8x30W



SUBWOOFER RGB



ΚΩΔΙΚΟΣ	ΤΥΠΟΣ	Amm	Bmm	Dmm	WATT(ζευγος)	ΧΡΩΜΑ
15.350B	10"	266	235	80	400	ΜΑΥΡΟ



15.127
VHF RS 509M CLASS D
DSC

Τεχνικά χαρακτηριστικά:

- Κατηγορία: Σχεδιασμένο για A1 και D
- Συχνότητες λειτουργίας: VHF
- Αριθμός καναλιών: 88 κανάλια
- Συχνότητες εκπομπής: 156.000-162.000MHz
- Συχνότητες λήψης: 156.000-163.425MHz
- Ισχύς εκπομπής: Επιλέξιμη 1W ή 25W
- Τάση λειτουργίας: DC 13.8V (±15%)
- Ενσωματωμένο μικρόφωνο
- Πρότυπα αντοχής: IP67
- Scan: Ναι

- GPS: **Ναι**

Περιεχόμενα συσκευασίας:

- RS 509MG
- Βάση τοποθέτησης
- Βάση στήριξης μικροφώνου
- Βιδάκια στερέωσης
- Καλώδιο τροφοδοσίας DC



15.129
HF RS25MWHF
MARINE IPX7

Τεχνικά χαρακτηριστικά:

- 200 προγραμματιζόμενα κανάλια
- Συχνότητα λειτουργίας: TX: 156.000-162.000MHz, RX: 156.000-163.275MHz
- Ισχύς εξόδου: 3W / 1W
- Μπαταρία: 5 850mAh AAA NiMH επαναφορτιζόμενες μπαταρίες
- Λειτουργεί με κλασικές αλκαλικές μπαταρίες (δεν περιλαμβάνονται)
- Αδιάβροχος κατά IP67 (σε βάθος νερού 1 μέτρο για 30 λεπτά)
- Λειτουργία Float (επιπλέει στο νερό)
- Συμπαγής κατασκευή, υψηλή απόδοση
- 10 κανάλια καιρού NOAA
- Λειτουργία Battery Save
- Λειτουργία SCAN
- Επιλογή υψηλής / χαμηλής ισχύος
- Λειτουργία Dual Watch / Tri-Watch

- Λειτουργία Call
- Γρήγορη επιλογή καναλιών με λειτουργία καναλιού προτίμησης
- Λειτουργία αποστράγγισης με δόνηση
- Λειτουργία Flash alarm για πτώση στο νερό (προαιρετικό)
- Θερμοκρασία λειτουργίας: -20°C + 60 °C
- Διαστάσεις (ΠxΥxΒ): 63x119x35mm
- Βάρος: 136g

Περιεχόμενα Συσκευασίας

- 1 x Recent RS-25M
- Φορτιστής 12V DC με επιτοίχιο αντάπτορα 100-240 AC
- Κεραία Rubber RA-25M
- 5 x επαναφορτιζόμενες μπαταρίες 850 mAh AAA NiMH



15.128
VHF 35M MARINE
ΦΟΡΗΤΟΣ FLOATING

Τεχνικά χαρακτηριστικά:

- Κατηγορία: Σχεδιασμένο για A1 και D
- Συχνότητες λειτουργίας: VHF
- Αριθμός καναλιών: 88 κανάλια
- Συχνότ. εκπομπής: 156.000-162.000MHz
- Συχνότ. λήψης: 156.000-163.425MHz
- Ισχύς εκπομπής: Επιλέξιμη 1W ή 25W
- Τάση λειτουργίας: DC 13.8V (±15%)
- Ενσωματωμένο μικρόφωνο
- Πρότυπα αντοχής: IP67
- Scan: Ναι
- GPS: Ναι

Περιεχόμενα συσκευασίας:

- RS 509MG
- Βάση τοποθέτησης
- Βάση στήριξης μικροφώνου
- Βιδάκια στερέωσης
- Καλώδιο τροφοδοσίας DC



15.130
ΚΕΡΑΙΑ ΕΣΩΤΕΡΙΚΗ AM-FM



15.137
ΚΕΡΑΙΑ VHF 100cm INOX



15.138 - 15.138B
ΚΕΡΑΙΑ VHF 25cm



15.133
ΚΕΡΑΙΑ VHF
ΜΕ ΒΑΣΗ 120cm



15.295
ΚΕΡΑΙΑ AM-FM RACING
25cm



15.134
ΚΕΡΑΙΑ TV ΜΕ ΒΑΣΗ
26dB



15.264
ΚΕΡΑΙΑ ΑΔΙΑΒΡΟΧΗ
ΓΙΑ ΡΑΔΙΟ AM/FM FLAT



15.296
ΚΕΡΑΙΑ ΑΔΙΑΒΡΟΧΗ
ΜΑΥΡΗ ΜΕ ΚΑΛΩΔΙΟ



15.338
ΚΕΡΑΙΑ VHF ΜΑΥΡΗ
ΜΕ ΒΑΣΗ INOX



15.140
ΚΕΡΑΙΑ TV ΜΕ ΒΑΣΗ
ΜΑΚΡΟΣΤΕΝΗ 26db



85.030
ΚΑΛΩΔΙΟ ΚΕΡΑΙΑΣ
-VHF RG-58



15.139
ΒΑΣΗ ΚΕΡΑΙΑΣ VHF
ΙΣΤΙΟΠΛΟΙΚΟΥ



15.132
ΒΑΣΗ ΚΕΡΑΙΑΣ
ΠΛΑΣΤΙΚΗ
ΣΠΕΙΡΩΜΑ 1 1/4"



15.131
ΒΑΣΗ ΚΕΡΑΙΑΣ
INOX
ΣΠΕΙΡΩΜΑ 1 1/4"



15.155
ΒΑΣΗ ΚΕΡΑΙΑΣ VHF
INOX
ΣΠΕΙΡΩΜΑ 1 1/4"



15.156
ΒΑΣΗ ΚΕΡΑΙΑΣ VHF
ΡΕΛΙ 7/8" - 1"
ΣΠΕΙΡΩΜΑ 1 1/4"



15.141
ΚΟΡΝΑ ΜΟΝΗ ΙΝΟΧ 12V



15.142
ΚΟΡΝΑ ΜΟΝΗ ΧΡΩΜΙΟΥ 12V



15.143
ΚΟΡΝΑ ΔΙΠΛΗ ΙΝΟΧ 12V



ΚΟΡΝΑ ΠΛΑΣΤΙΚΗ
(ΠΑΠΙ) 12V
15.145A ΛΕΥΚΟ
15.145B ΜΑΥΡΟ



15.146
ΚΟΡΝΑ ΣΑΛΙΓΚΑΡΙ ΙΝΟΧ 12V



15.147
ΚΟΡΝΑ ΤΕΤΡΑΓΩΝΗ ΠΛΑΣΤΙΚΗ 12V



15.148
ΚΟΡΝΑ ΧΩΝΕΥΤΗ ΣΤΕΝΗ 105db 12V



15.242
ΚΟΡΝΑ ΧΩΝΕΥΤΗ 112db 12V

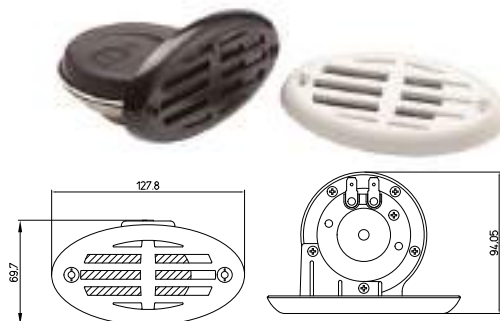

15.144
ΚΟΡΝΑ ΧΩΝΕΥΤΗ ΛΕΥΚΟ-ΜΑΥΡΟ



15.501 ΚΟΜΠΡΕΣΕΡ 8bar 24V 240W



15.161
ΤΡΟΜΠΕΤΑ ΠΛΑΣΤΙΚΗ
(ΚΟΡΝΑ ΟΜΙΧΛΗΣ)



15.152 - ΜΗΧΑΝΙΣΜΟΣ ΚΟΡΝΑΣ
15.153 - ΦΙΑΛΗ ΚΟΡΝΑΣ



ΚΟΡΝΑ ΗΛΕΚΤΡΙΚΗ
ΕΓΚΕΚΡΙΜΕΝΗ
15.237A 12V έως 20m
15.237B 24V έως 20m
15.277 24V έως 75m*
*ΧΩΡΙΣ COMPRESSOR



15.187A ΑΕΡΑΓΩΓΟΣ ΒΤ
320FM 12V Φ100mm
15.187B ΑΕΡΑΓΩΓΟΣ ΒΤ
320FM 24V Φ100mm

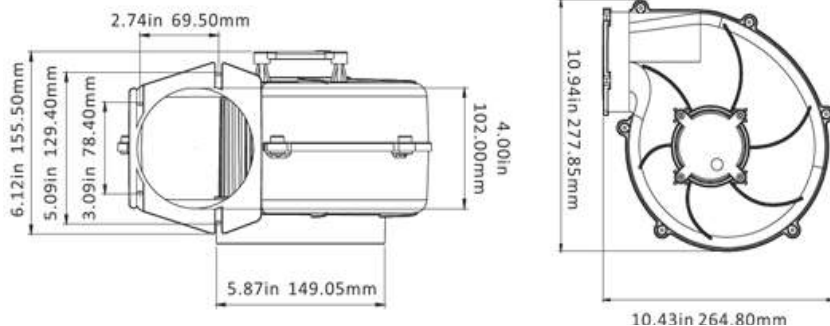

15.188A ΑΕΡΑΓΩΓΟΣ ΒΤ 320FM
12V Φ100mm ΜΕ ΒΑΣΗ
15.188B ΑΕΡΑΓΩΓΟΣ ΒΤ 320FM
24V Φ100mm ΜΕ ΒΑΣΗ

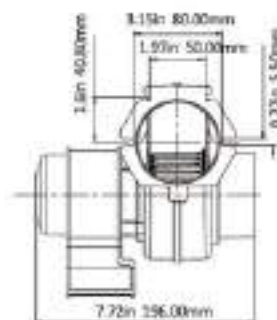
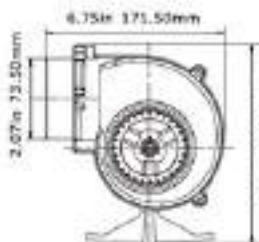
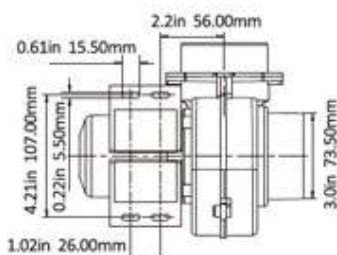
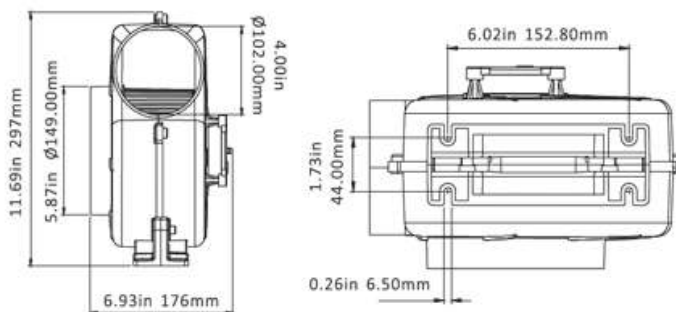

15.193 - ΑΕΡΑΓΩΓΟΣ ΣΑΛΙΓΚΑΡΙ 130 CMF Φ76mm 12V
15.194 - ΑΕΡΑΓΩΓΟΣ ΣΑΛΙΓΚΑΡΙ 130 CMF Φ76mm 24V



15.195 ΑΕΡΑΓΩΓΟΙ
ΙΣΙΟΣ 12V Ø76mm
15.196 ΑΕΡΑΓΩΓΟΙ
ΙΣΙΟΣ 24V Ø76mm

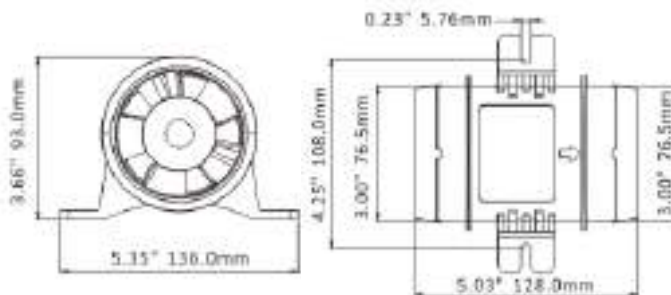

ΣΩΛΗΝΑ ΑΕΡΑΓΩΓΟΥ

15.184 Φ 76mm
15.186 Φ100mm



15.197 ΑΕΡΑΓΩΓΟΣ
ΙΣΙΟΣ 12V Ø100mm
15.198 ΑΕΡΑΓΩΓΟΣ
ΙΣΙΟΣ 24V Ø100mm

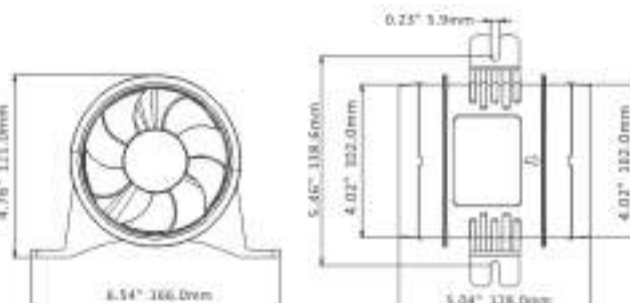

ΑΕΡΑΓΩΓΟΙ-ΑΝΕΜΙΣΤΗΡΕΣ

ΗΛΕΚΤΡΟΛΟΓΙΚΟΣ ΕΞΟΠΛΙΣΜΟΣ



98.172
ΑΝΕΜΙΣΤΗΡΑΣ
ΜΕ ΠΡΙΖΑ ΑΝΑΠΤΗΡΑ



98.192
ΑΝΕΜΙΣΤΗΡΑΣ 12V



98.194
ΑΝΕΜΙΣΤΗΡΑΣ
SAFRAMO BORA
ΛΕΥΚΟΣ 15CM 12V



98.173
ΠΙΣΤΟΛΑΚΙ ΜΕ ΠΡΙΖΑ
12V



98.193
ΑΝΕΜΙΣΤΗΡΑΣ 7"
3 ΤΑΧΥΤΗΤΩΝ 12V
Α ΛΕΥΚΟΣ / Β ΜΑΥΡΟΣ



98.195
ΑΝΕΜΙΣΤΗΡΑΣ 6"
3 ΤΑΧΥΤΗΤΩΝ
Α ΛΕΥΚΟΣ / Β ΜΑΥΡΟΣ



98.124
ΣΚΟΥΠΑΚΙ ΜΙΝΙ 12V
ΕΠΑΝΑΦ/ΝΟ

ΔΙΑΚΟΠΤΕΣ ΜΠΑΤΑΡΙΑΣ

ΗΛΕΚΤΡΟΛΟΓΙΚΟΣ ΕΞΟΠΛΙΣΜΟΣ



14.127
ΔΙΑΚΟΠΤΗΣ ΜΠΑΤΑΡΙΑΣ
1000A/ON-OFF 1000A

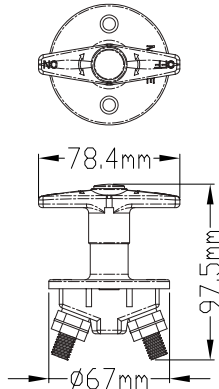

14.129
ΔΙΑΚΟΠΤΗΣ ΜΠΑΤΑΡΙΑΣ
ON-OFF B.T. 250A/
ΜΕ ΚΛΕΙΔΙ INOX max 2000A

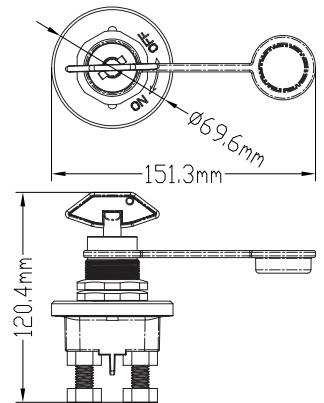

18.527
ΔΙΑΚΟΠΤΗΣ ΜΠΑΤΑΡΙΑΣ
ON-OFF
100A/max 1000A

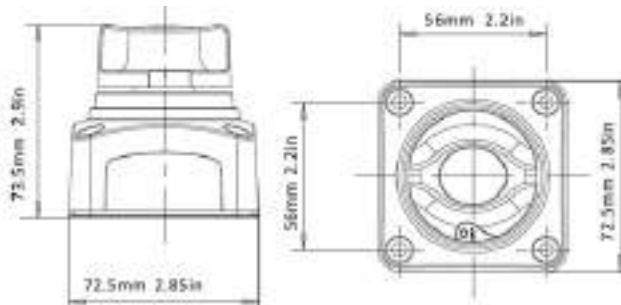

14.135
ΔΙΑΚΟΠΤΗΣ ΜΠΑΤΑΡΙΑΣ
BT SF ON-OFF max 900A

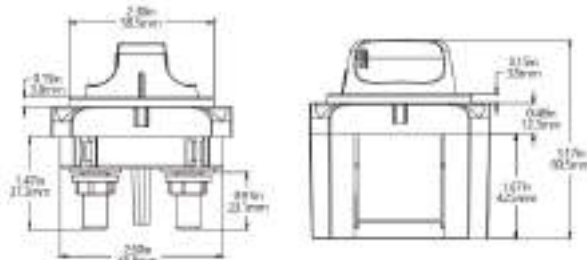

14.121
ΔΙΑΚΟΠΤΗΣ ΜΠΑΤΑΡΙΑΣ ΒΟΤΗ
ΜΑΥΡΟΣ ΓΙΑ ΔΥΟ ΜΠΑΤΑΡΙΑΣ
175A/max 300A

SEAFLO



18.540
ΔΙΑΚΟΠΤΗΣ ΜΠΑΤΑΡΙΑΣ
ΒΟΤΗ ΛΕΥΚΟΣ
ΓΙΑ 2 ΜΠΑΤΑΡΙΑΣ max 300A



14.125
ΔΙΑΚΟΠΤΗΣ ΜΠΑΤΑΡΙΑΣ
ΜΕ ΚΛΕΙΔΙ 100A/max
1000A



14.130
ΑΝΤΑΛ/ΚΟ ΚΛΕΙΔΙ
ΔΙΑΚΟΠΤΗ
ΜΠΑΤΑΡΙΑΣ

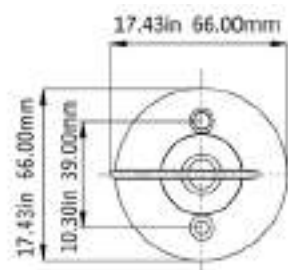
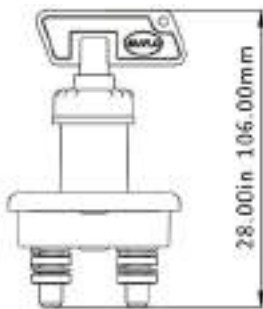

14.126
ΔΙΑΚΟΠΤΗΣ ΜΠΑΤΑΡΙΑΣ
ΜΕ ΚΛΕΙΔΙ ΧΩΝΕΥΤΟΣ
100A/max1000A

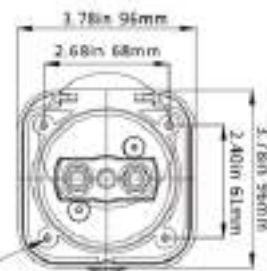
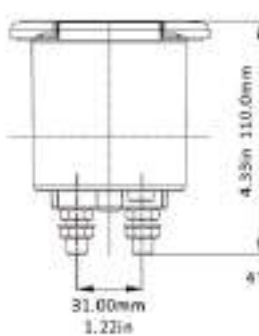

14.136
ΔΙΑΚΟΠΤΗΣ ΜΠΑΤΑΡΙΑΣ
BT SF B0TH 300A max 900A

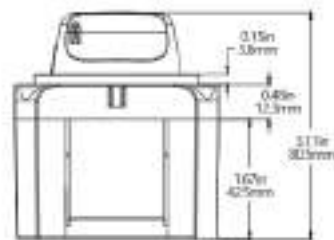
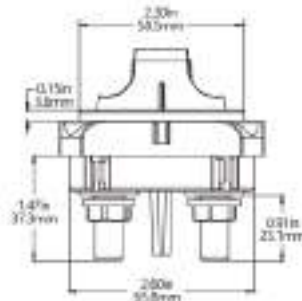

14.123
ΔΙΑΚΟΠΤΗΣ ΓΙΑ 2 ΜΠΑΤΑΡΙΕΣ
B0TH ΜΙΚΡΟΣ 100A max 300A

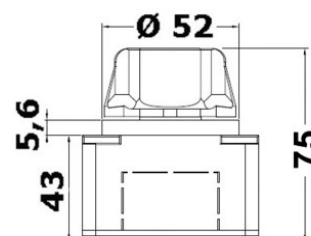
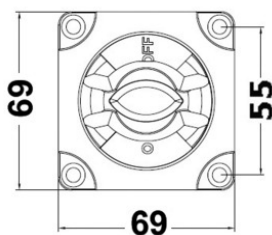

90.038
ΔΙΑΚΟΠΤΗΣ ΜΠΑΤΑΡΙΑΣ
B0TH 350A-600A

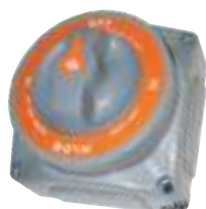

90.034
ΔΙΑΚΟΠΤΗΣ ΜΠΑΤΑΡΙΑΣ ΜΚ2
B0TH ΓΙΑ 2 ΜΠΑΤΑΡΙΕΣ
ΣΥΝΕΧΟΜΕΝΟ 300A/max 450A

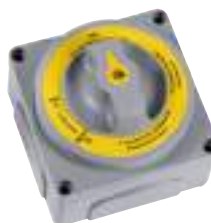

90.035
ΔΙΑΚΟΠΤΗΣ ΜΠΑΤΑΡΙΑΣ ΜΚ3
B0TH ΓΙΑ 2 ΜΠΑΤΑΡΙΕΣ
300A/450A

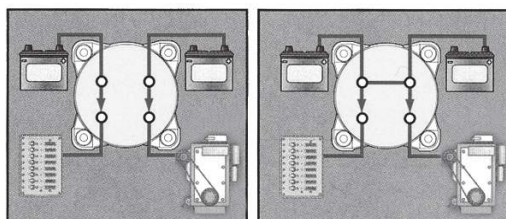
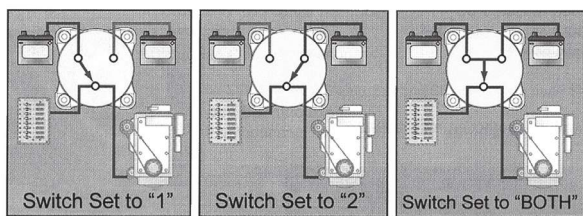



ΚΩΔ.	AH(C20)	A(EN)	ΤΥΠΟΣ	ΤΥΠΟΣ	ΔΙΑΣΤΑΣΕΙΣ
14.206	44	390		ΚΛΕΙΣΤΟΥ ΤΥΠΟΥ	207x175x175
14.207	65	540		ΚΛΕΙΣΤΟΥ ΤΥΠΟΥ	242x175x190
14.208	80	680		ΚΛΕΙΣΤΟΥ ΤΥΠΟΥ	275x175x190
14.209	100	850		ΚΛΕΙΣΤΟΥ ΤΥΠΟΥ	306x175x190
14.115	60	680		AGM TECHNOLOGY	242x175x190
14.116	70	760		AGM TECHNOLOGY	275x175x190
14.117	95	900		AGM TECHNOLOGY	354x175x190
14.211	145	850		ΚΛΕΙΣΤΟΥ ΤΥΠΟΥ	513x189x223
14.212	180	1200		ΚΛΕΙΣΤΟΥ ΤΥΠΟΥ	513x223x223
14.213	230	1350		ΚΛΕΙΣΤΟΥ ΤΥΠΟΥ	513x273x240



ΚΩΔΙΚΟΣ	ΜΟΝΤΕΛΟ	BLISTER (ΤΕΜ)
14.215	AA-LR-6	4
14.216	AAA-LR-03	4
14.217	C-LR14	2
14.218	D-LR20	2



ΦΟΡΤΙΣΤΗΣ ΜΠΑΤΑΡΙΑΣ

- 17.801 25A 12V 2 ΕΞΟΔΩΝ
- 17.802 40A 12V 3 ΕΞΟΔΩΝ
- 17.803 50A 12V 3 ΕΞΟΔΩΝ
- 17.806 40A 24V 3 ΕΞΟΔΩΝ

INVERTER ΚΑΘΑΡΟΥ ΗΜΙΤΟΝΟΥ

- 17.811 400W 12-220V
- 17.812 700W 12-220V
- 17.813 1.000W 12-220V
- 17.814 2.000W 12-220V
- 17.816 1.000W 24-220V
- 17.817 2.000W 24-220V



14.205

ΚΑΛΥΜΜΑ ΠΟΛΟΥ
ΚΟΚΚΙΝΟ ΜΑΥΡΟ (ΖΕΥΓΟΣ)



14.204

ΠΟΛΟΙ ΜΠΑΤΑΡΙΑΣ ΙΝΟΧ
ΜΕ ΚΑΠΑΚΙ ΑΠΟΣΠΩΜΕΝΟΙ



14.220

ΠΟΛΟΙ ΜΠΑΤΑΡΙΑΣ ΜΠΡΟΥΤΖΙΝΟΙ
ΜΕ ΠΕΤΑΛΟΥΔΑ



14.200

ΠΟΛΟΙ ΜΠΑΤΑΡΙΑΣ ΝΙΚΕΛ
ΜΕ ΠΕΤΑΛΟΥΔΑ



- 14.301 - ISOLATOR 2 ΜΠΑΤΑΡΙΕΣ 100A
- 14.302 - ISOLATOR 3 ΜΠΑΤΑΡΙΕΣ 100A



14.201

ΠΟΛΟΙ ΜΠΑΤΑΡΙΑΣ
ΜΟΛΥΒΕΝΙΟΙ



14.202

ΠΟΛΟΙ ΜΠΑΤΑΡΙΑΣ
ΙΝΟΧ



- 15.202 - ΘΗΚΗ ΜΠΑΤΑΡΙΑΣ ΜΙΚΡΗ L 28 x W 20 cm
- 15.201 - ΘΗΚΗ ΜΠΑΤΑΡΙΑΣ ΜΕΓΑΛΗ L 33 x W 20 cm
- 15.208 - ΘΗΚΗ ΜΠΑΤΑΡΙΑΣ XLARGE L 40 x W 20 cm



- 15.203
ΘΗΚΗ ΓΙΑ ΔΥΟ ΜΠΑΤΑΡΙΕΣ ή ΜΙΑΣ ΜΕΓΑΛΗΣ
L 52 x W 27 cm



15.205

ΘΗΚΗ ΜΠΑΤΑΡΙΑΣ ΜΕ ΣΤΗΡΙΓΜΑΤΑ
L33 x W 19 cm



15.204

ΘΗΚΗ ΜΠΑΤΑΡΙΑΣ ΜΕ ΙΜΑΝΤΑ
L 33 x W 19 cm



15.207

ΘΗΚΗ ΜΠΑΤΑΡΙΑΣ ΕΥΚΑΜΠΤΗ
ΜΕ ΙΜΑΝΤΑ / L 48 x W 34 cm



ΚΩΣ ΧΑΛΚΟΥ ΕΠΙΚΑΣΣΙΤΕΡΩΜΕΝΑ ΜΕ ΟΠΗ

ΚΩΔΙΚΟΣ	ΚΑΛΩΔΙΟ	ΤΡΥΠΑ mm	ΧΡΩΜΑ
85.101	0.5-1.5mm	4.3	ΚΟΚΚΙΝΟ
85.102	0.5-1.5mm	5.3	ΚΟΚΚΙΝΟ
85.103	0.5-1.5mm	6.4	ΚΟΚΚΙΝΟ
85.104	1.5-2.5mm	4.3	ΜΠΛΕ
85.105	1.5-2.5mm	5.3	ΜΠΛΕ
85.106	1.5-2.5mm	6.4	ΜΠΛΕ
85.107	2,5-6,0mm	6.4	ΚΙΤΡΙΝΟ
85.108	2,5-6,0mm	8.4	ΚΙΤΡΙΝΟ
85.109	2,5-6,0mm	10	ΚΙΤΡΙΝΟ



ΚΩΣ ΣΥΡΤΑΡΩΤΟ ΕΠΙΚΑΣΣΙΤΕΡΩΜΕΝΟ

ΚΩΔΙΚΟΣ	ΚΑΛΩΔΙΟ	ΤΡΥΠΑ mm	ΧΡΩΜΑ
85.151	0.5-1.5mm	6.3	ΚΟΚΚΙΝΟ
85.152	1.5-2.5mm	6.3	ΜΠΛΕ
85.153	2,5-6,0mm	9.5	ΚΙΤΡΙΝΟ



ΘΕΡΜΟΣΥΣΤΕΛΩΜΕΝΑ ΚΑΛΩΔΙΟΥ

ΚΩΔΙΚΟΣ ΚΟΚΚΙΝΟ	ΚΩΔΙΚΟΣ ΜΑΥΡΟ	ΔΙΑΜΕΤΡΟΣ	ΜΗΚΟΣ	ΤΕΜ
85.191A	85.191B	3,2mm	150mm	25
85.192A	85.192B	4,8mm	150 mm	20
85.193A	85.193B	12,7mm	150mm	10



ΚΩΣ ΘΕΡΜΟΣΥΣΤΕΛΩΜΕΝΟ

ΚΩΔΙΚΟΣ	ΚΑΛΩΔΙΟ	ΧΡΩΜΑ
85.161	0.5-1.5mm	ΡΟΖ
85.162	1.5-2.5mm	ΜΠΛΕ
85.163	2,5-6,0mm	ΚΙΤΡΙΝΟ



ΣΥΝΔΕΤΗΡΑΣ ΚΑΛΩΔΙΟΥ

ΚΩΔΙΚΟΣ	ΚΑΛΩΔΙΟ	ΧΡΩΜΑ
85.171	0.5-1.1mm	ΚΟΚΚΙΝΟ
85.172	1.5-2.5mm	ΜΠΛΕ
85.173	4,0-6,0mm	ΚΙΤΡΙΝΟ



ΑΚΡΟΔΕΚΤΗΣ ΧΑΛΚΟΥ

ΚΩΔΙΚΟΣ	ΚΑΛΩΔΙΟ	ΤΡΥΠΑ mm
85.140	10mm	6,9
85.141	16mm	8,6
85.142	25mm	8,5
85.143	35mm	8,4
85.144	50mm	10,6
85.145	60-70mm	10,2
85.146	95mm	10.4



ΣΩΛΗΝΑΣ ΠΡΟΣΤΑΣΙΑΣ ΚΑΛΩΔΙΟΥ

ΚΩΔΙΚΟΣ	ΔΙΑΜΕΤΡΟΣ	ΜΕΤΡΑ
85.181	12mm	25
85.182	20mm	25
85.183	28mm	25



ΜΥΥ ΚΑΛΩΔΙΑ FLAME RETARDANT PVC, YACHT POWER CABLE

ΚΩΔΙΚΟΣ	ΧΡΩΜΑ	ΠΕΡΙΓΡΑΦΗ	ΚΩΔΙΚΟΣ	ΧΡΩΜΑ	ΠΕΡΙΓΡΑΦΗ	
85.000		<p>1 x 1</p>	85.003A		<p>1 x 4</p>	
85.000B						
85.000C						
85.000D						
85.001A		<p>1 x 1.5</p>	85.004A		<p>1 x 6</p>	
85.001B						
85.001Y						
85.001BR						
85.001GR						
85.001PU						
85.001P						
85.001G						
85.001O						
85.001W						
85.001BL						
85.002A			<p>1 x 2.5</p>	85.005A		<p>1 x 10</p>
85.002B						
85.002Y						
85.002BR						
85.002GR						
85.002PU						
85.002P						
85.002G						
85.002OR						
85.002W						
85.002BL						
85.006A		<p>1 x 16</p>		85.007A		<p>1 x 25</p>
	85.006B					
85.007A		<p>1 x 25</p>	85.007B		<p>1 x 25</p>	
	85.007B					























ΜΥΥ ΚΑΛΩΔΙΑ FLAME RETARDANT PVC, YACHT POWER CABLE

ΚΩΔΙΚΟΣ	ΧΡΩΜΑ	ΠΕΡΙΓΡΑΦΗ
85.008A		1 x 35
85.008B		
85.009A		1 x 50
85.009B		
85.015A		1 X 70
85.015B		
85.016A		1 X 95
85.016B		
85.035		2 X 0.75

ΚΩΔΙΚΟΣ	ΧΡΩΜΑ	ΠΕΡΙΓΡΑΦΗ
85.010		2 X 1.5
85.133		2 X 1.5 FLAT
85.025		3 X 1.5
85.019		3 X 1.5 FLAT
85.026		4 X 1.5

















ΜΥΥ ΚΑΛΩΔΙΑ FLAME RETARDANT PVC, YACHT POWER CABLE

ΚΩΔΙΚΟΣ	ΧΡΩΜΑ	ΠΕΡΙΓΡΑΦΗ	ΚΩΔΙΚΟΣ	ΧΡΩΜΑ	ΠΕΡΙΓΡΑΦΗ
85.020		<p>5 X 1.5</p> 	85.134		<p>2 X 2.5 FLAT</p> 
85.021		<p>7 X 1.5</p> 	85.012		<p>3 X 2.5</p> 
85.024		<p>10 X 1.5</p> 	85.036		<p>6 X 2.5</p> 
85.014		<p>12 X 1.5</p> 	85.018		<p>7 X 2.5</p> 
85.011		<p>2 X 2.5</p> 	85.023		<p>10 X 2.5</p> 































ΜΥΥ ΚΑΛΩΔΙΑ FLAME RETARDANT PVC, YACHT POWER CABLE

ΚΩΔΙΚΟΣ	ΧΡΩΜΑ	ΠΕΡΙΓΡΑΦΗ
ΚΩΔΙΚΟΣ	ΧΡΩΜΑ	ΠΕΡΙΓΡΑΦΗ
85.027		2 X 4 
85.029		3 x 4 
85.028		2 X 6 
85.013		2 X 0.5 SPEAKER 
85.017		2 X 0.75 SPEAKER 

ΚΩΔΙΚΟΣ	ΧΡΩΜΑ	ΠΕΡΙΓΡΑΦΗ
ΚΩΔΙΚΟΣ	ΧΡΩΜΑ	ΠΕΡΙΓΡΑΦΗ
85.022		2 X 1.5 SPEAKER 
85.031		3 X 2.5 SHORE POWER 
85.034		3 X 4 SHORE POWER 
85.032		3 X 6 SHORE POWER 
85.033		3 X 10 SHORE POWER 



ΜΧ ΚΑΛΩΔΙΑ HALOGEN-FREE, FLAME RETERDANT, INSULATED PANEL CABLE

ΚΩΔΙΚΟΣ	ΧΡΩΜΑ	ΠΕΡΙΓΡΑΦΗ	ΚΩΔΙΚΟΣ	ΧΡΩΜΑ	ΠΕΡΙΓΡΑΦΗ
84.001A		1 x 1.5 	84.006A		1 x 16 
84.001B			84.006B		
84.002A		1 x 2.5 	84.007A		1 x 25 
84.002B			84.007B		
84.003A		1 x 4 	84.008A		1 x 35 
84.003B			84.008B		
84.004A		1 x 6 	84.009A		1 X 50 
84.004B			84.009B		
84.005A		1 x 10 	85.030		RG-58 
84.005B					



ΟΡΓΑΝΟ ΚΑΥΣΙΜΟΥ
ΛΕΥΚΟ ΙΝΟΧ
93.194-A 240/33Ω
93.196-A 10/180Ω



ΟΡΓΑΝΟ ΚΑΥΣΙΜΟΥ
ΜΑΥΡΟ ΙΝΟΧ
93.194-B 240/33Ω
93.196-B 10/180Ω



ΟΡΓΑΝΟ ΜΕΤΡΗΣΗΣ
ΚΑΥΣΙΜΟΥ ΜΑΥΡΟ-ΙΝΟΧ
93.199-A 10-180Ω
93.199-B 240-30Ω



93.191
ΑΙΣΘΗΤΗΡΑΣ ΠΙΕΣΗΣ
ΛΑΔΙΟΥ



93.182-A
ΜΙΛΙΟΜΕΤΡΟ 0-55 MPH
ΙΝΟΧ ΛΕΥΚΟ



ΒΟΛΤΟΜΕΤΡΟ ΛΕΥΚΟ ΙΝΟΧ
93.185-A 8-16V
93.186-A 8-32V



ΟΡΓΑΝΟ ΜΕΤΡΗΣΗΣ ΝΕΡΟΥ
ΛΕΥΚΟ-ΙΝΟΧ
93.197-A 10/180Ω
93.198-A 240/30Ω



ΣΤΡΟΦΟΜΕΤΡΟ ΜΕ ΨΗΦΙΑΚΟ
ΩΡΟΜΕΤΡΟ ΙΝΟΧ ΛΕΥΚΟ
93.181A 0-8000 RPM
93.193A 0-4000 RPM



93.182-B
ΜΙΛΙΟΜΕΤΡΟ 0-55 MPH
ΙΝΟΧ ΜΑΥΡΟ



ΒΟΛΤΟΜΕΤΡΟ ΜΑΥΡΟ ΙΝΟΧ
93.185-B 8-16V
93.186-B 18-32V



ΟΡΓΑΝΟ ΜΕΤΡΗΣΗΣ ΝΕΡΟΥ
ΜΑΥΡΟ-ΙΝΟΧ
93.197-B 10/180Ω
93.198-B 240/30Ω



ΣΤΡΟΦΟΜΕΤΡΟ ΜΕ ΨΗΦΙΑΚΟ
ΩΡΟΜΕΤΡΟ ΙΝΟΧ ΜΑΥΡΟ
93.181-B 0-8000 RPM
93.193-B 0-4000 RPM



93.187-A
ΟΡΓΑΝΟ ΠΙΕΣΗΣ ΛΑΔΙΟΥ 0-10
BAR ΙΝΟΧ ΛΕΥΚΟ



93.184-A
ΟΡΓΑΝΟ ΘΕΡΜΟΚΡΑΣΙΑΣ
ΛΑΔΙΟΥ ΙΝΟΧ ΛΕΥΚΟ



93.188-A
ΤΡΙΜΟΜΕΤΡΟ ΙΝΟΧ ΛΕΥΚΟ



93.200-A
ΟΡΓΑΝΟ ΚΑΥΣΙΜΟΥ
10-180Ω & 240-33Ω ΛΕΥΚΟ



93.187-B
ΟΡΓΑΝΟ ΠΙΕΣΗΣ ΛΑΔΙΟΥ
0-10 BAR ΙΝΟΧ ΜΑΥΡΟ



93.184-B
ΟΡΓΑΝΟ ΘΕΡΜΟΚΡΑΣΙΑΣ
ΛΑΔΙΟΥ ΙΝΟΧ ΜΑΥΡΟ



93.188-B
ΤΡΙΜΟΜΕΤΡΟ ΙΝΟΧ ΜΑΥΡΟ



93.200-B
ΟΡΓΑΝΟ ΚΑΥΣΙΜΟΥ
10-180Ω & 240-33Ω ΜΑΥΡΟ



93.189-A

ΩΡΟΜΕΤΡΟ ΨΗΦΙΑΚΟ ΙΝΟΧ ΛΕΥΚΟ



93.189-B

ΩΡΟΜΕΤΡΟ ΨΗΦΙΑΚΟ ΙΝΟΧ ΜΑΥΡΟ



93.183-A

ΟΡΓΑΝΟ ΘΕΡΜΟΚΡΑΣΙΑΣ ΝΕΡΟΥ ΙΝΟΧ ΛΕΥΚΟ



93.183-B

ΟΡΓΑΝΟ ΘΕΡΜΟΚΡΑΣΙΑΣ ΝΕΡΟΥ ΙΝΟΧ ΜΑΥΡΟ



93.192

ΑΙΣΘΗΤΗΡΑΣ ΘΕΡΜΟΚΡΑΣΙΑΣ



93.190

ΠΟΔΑΡΑΚΙ ΜΙΛΙΟΜΕΤΡΟΥ



93.195

ΣΩΛΗΝΑΚΙ ΜΙΛΙΟΜΕΤΡΟΥ



ΜΕΤΡΗΤΕΣ ΗΛΕΚΤΡ. ΚΑΥΣΙΜΟΥ-ΝΕΡΟΥ

ΚΩΔ.	10/180 Ω	ΚΩΔ.	240/33 Ω
31.017	17cm	31.117	17cm
31.020	20cm	31.120	20cm
31.022	22cm	31.122	22cm
31.025	25cm	31.125	25cm
31.028	28cm	31.128	28cm
31.030	30cm	31.130	30cm
31.035	35cm	31.135	35cm
31.039	39cm	31.139	39cm
31.050	50cm	31.150	50cm
31.060	60cm	31.160	60cm
31.080	80cm	31.180	80cm



93.211
ΒΑΡΟΜΕΤΡΟ ΜΠΡΟΥΤΖΙΝΟ 85mm



93.212
ΡΟΛΟΙ ΜΠΡΟΥΤΖΙΝΟ 85mm



93.215
ΒΑΡΟΜΕΤΡΟ ΘΕΡΜΟΜΕΤΡΟ ΥΓΡΟΜΕΤΡΟ 310x120mm



93.216
ΒΑΡΟΜΕΤΡΟ ΘΕΡΜΟΜΕΤΡΟ ΥΓΡΟΜΕΤΡΟ 390x130mm



93.217
ΒΑΡΟΜΕΤΡΟ ΘΕΡΜΟ/ΡΟΛΟΪ ΥΓΡΟΜΕΤΡΟ 390x130mm



93.213
ΘΕΡΜΟΜΕΤΡΟ-ΥΓΡΟΜΕΤΡΟ ΜΠΡΟΥΤΖΙΝΟ 85mm



95.130
ΑΣΦΑΛΕΙΟΘΗΚΗ ANL



95.401
ΑΣΦΑΛΕΙΟΘΗΚΗ 12 ΘΕΣΕΩΝ
L17 x W9cm



95.400
ΑΣΦΑΛΕΙΟΘΗΚΗ
6 ΘΕΣΕΩΝ 12.5x9cm



95.129
ΑΣΦΑΛΕΙΕΣ ΜΑΧΑΙΡΩΤΕΣ ΣΕΤ
36TMX



95.405
ΑΣΦΑΛΕΙΟΘΗΚΗ
ΣΥΝΑΡΜΟΛΟΓΗΣΗΣ
ΜΕ LED 6 ΘΕΣΕΩΝ



95.406
ΜΠΑΡΑ ΑΡΝΗΤΙΚΗ 12 ΘΕΣΕΩΝ
ΓΙΑ ΑΣΦΑΛΕΙΟΘΗΚΗ
ΣΥΝΑΡΜΟΛΟΓΗΣΗΣ

ΑΣΦΑΛΕΙΑ ΜΑΧΑΙΡΩΤΗ



95.121	5A
95.122	10A
95.123	15A
95.124	20A
95.125	30A



ΑΣΦΑΛΕΙΑ ANL
95.134A 250A
95.134B 300A
95.134C 400A
95.134D 500A



95.410
ΑΣΦΑΛΕΙΟΘΗΚΗ
ΜΕ ΚΑΛΩΔΙΟ 30A



6P Fuse Block

BF271 6P Fuse Block



12P Negative Bus Bar

BF273 6P Fuse Block with Negative Bus Bar

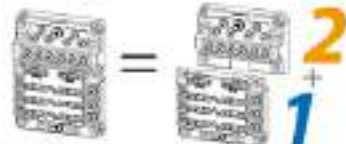

※ BF273 comes with 6 circuits negative bus bar when sold pre-assembled in factory.

BF274 12P Fuse Block



BF275 12P Fuse Block with Negative Bus Bar





15.241

**ΠΙΝΑΚΑΣ ΙΤΑΛΙΑΣ ΜΕ ΑΥΤΟΜΑΤΕΣ ΑΣΦΑΛΕΙΕΣ 6 ΘΕΣΕΩΝ
4 ON-OFF+1 (ON)-OFF +1 ON-OFF-ON
H 190 x W 140mm**



15.249

**ΠΙΝΑΚΑΣ 5 ΘΕΣΕΩΝ ΜΕ ΠΡΙΖΑ ΑΝΑΠΤΗΡΑ
H110 x W125mm**



15.000

**ΠΙΝΑΚΑΣ ΠΡΙΖΑ 50 USB ΑΔΙΑΒΡΟΧΟΣ
H110xW98mm**



ΠΙΝΑΚΑΣ ΜΑΥΡΟΣ LED ΜΕ ΠΛΑΚΕΤΑ/15A

15.015 - 4 ΔΙΑΚΟΠΤΕΣ H 110 x W 98mm

15.016 - 6 ΔΙΑΚΟΠΤΕΣ H 152 x W 98mm



15.010

ΠΙΝΑΚΑΣ 3Θ ΜΕ ΠΡΙΖΑ USB 110Hx98W



15.250

**ΠΙΝΑΚΑΣ 3 ΘΕΣΕΩΝ ΜΕ ΠΡΙΖΑ ΑΝΑΠΤΗΡΑ
H110 x W98mm**



ΔΙΑΚΟΠΤΗΣ

95.201 - ON-OFF

95.202 - (ON)-OFF

95.203 - ON-OFF-ON

95.204 - (ON)-OFF-(ON)

95.205 - ON-OFF-(ON)



95.261

ΘΗΚΗ ΔΙΑΚΟΠΤΗ ΑΚΡΗ

**95.5xx
ΚΑΠΑΚΙ ΔΙΑΚΟΠΤΗ CARLING**



95.263

ΘΗΚΗ ΔΙΑΚΟΠΤΗ ΜΟΝΗ



95.260

ΘΗΚΗ ΔΙΑΚΟΠΤΗ ΚΕΝΤΡΟ



95.262

ΚΑΠΑΚΙ ΘΗΚΗΣ ΚΛΕΙΣΤΟ



15.258
ΠΙΝΑΚΑΣ ΜΕ 6 ΜΕΓΑΛΟΥΣ ΔΙΑΚΟΠΤΕΣ
LED ΜΕ ΑΥΤΟΜΑΤΕΣ ΑΣΦΑΛΕΙΕΣ
ΑΔΙΑΒΡΟΧΟΣ IP65
H195 x W130mm



15.014
ΠΙΝΑΚΑΣ ΜΕ
ΑΥΤΟΜΑΤΕΣ ΑΣΦΑΛΕΙΕΣ
5Θ ΜΕ USB
H 190 x W140mm



15.020
ΠΙΝΑΚΑΣ ΜΕ
ΑΥΤΟΜΑΤΕΣ ΑΣΦΑΛΕΙΕΣ 7Θ ΜΕ USB
H 242 x W114mm



15.017
ΠΙΝΑΚΑΣ 3 ΘΕΣΕΩΝ LED
ΜΕ ΑΥΤΟΜΑΤΕΣ ΑΣΦΑΛΕΙΕΣ
ΚΑΙ ΜΕΓΑΛΟΥΣ ΔΙΑΚΟΠΤΕΣ
H 95 x W133mm



15.018
ΠΙΝΑΚΑΣ 6 ΜΕΓΑΛΟΥΣ
ΔΙΑΚΟΠΤΕΣ LED ΜΕ ΑΥΤΟΜΑΤΕΣ
ΑΦΑΛΕΙΕΣ 5 ON-OFF + 1 (ON)-OFF
H 190 x W140mm



15.019
ΠΙΝΑΚΑΣ 8 ΔΙΑΚΟΠΤΕΣ LED
(7+1 ΣΤΙΓΜΙΑΙΟ) ΑΥΤΟΜΑΤΕΣ
ΑΣΦΑΛΕΙΕΣ ΑΔΙΑΒΡΟΧΟΣ IP65
H 242 x W 114mm



15.005
ΠΙΝΑΚΑΣ 8 ΔΙΑΚΟΠΤΕΣ ΦΩΤΙΖΟΜΕΝΟΙ
ΜΕ ΑΥΤΟΜΑΤΕΣ ΑΣΦΑΛΕΙΕΣ
23,5x12cm



15.008
ΠΙΝΑΚΑΣ 4 ΔΙΑΚΟΠΤΕΣ ΦΩΤΙΖΟΜΕΝΟΙ
12.5x6.5cm



15.009
ΠΙΝΑΚΑΣ 6 ΔΙΑΚΟΠΤΕΣ ΦΩΤΙΖΟΜΕΝΟΙ
18x6.5cm



14.057
ΠΙΝΑΚΑΣ 3 Θ ΜΕ USB+ΒΟΛΤΟΜΕΤΡΟ
9.5x11cm



14.058
ΠΙΝΑΚΑΣ 4 Θ ΜΕ ΠΡΙΖΑ ΑΝΑΠΤΗ-
ΡΑ+USB+ΒΟΛΤΟΜΕΤΡΟ
12,5x11cm



14.059
ΠΙΝΑΚΑΣ 6 Θ ΜΕ ΠΡΙΖΑ ΑΝΑΠΤΗΡΑ + USB
+ΒΟΛΤΟΜΕΤΡΟ
18x10.5cm



15.035
ΠΙΝΑΚΑΣ ΜΕ 6 PUSH
ΔΙΑΚΟΠΤΕΣ 157 x 25mm



15.036
ΠΙΝΑΚΑΣ ΜΕ 4 PUSH
ΔΙΑΚΟΠΤΕΣ
25 x 105mm



15.063
ΠΙΝΑΚΑΣ ΑΝΤΛΙΑΣ ΣΕΝΤΙΝΑΣ
ΓΙΑ ΑΥΤΟΜΑΤΗ ΑΝΤΛΙΑ 10-30V



15.065
ΠΙΝΑΚΑΣ 6 ΘΕΣΕΩΝ ΜΕ ΑΥΤΟΜΑΤΕΣ
ΑΣΦΑΛΕΙΕΣ ΚΑΙ ΜΙΚΡΟΥΣ ΔΙΑΚΟΠΤΕΣ
L 170 x W 90mm



ΠΙΝΑΚΑΣ LED/ΜΕΓΑΛΟΙ ΔΙΑΚΟΠΤΕΣ
15.006 3 ΔΙΑΚΟΠΤΕΣ H 95 x W140mm
15.007 6 ΔΙΑΚΟΠΤΕΣ H 190 x W 140mm



15.066
ΠΙΝΑΚΑΣ 3 ΘΕΣΕΩΝ ΜΕ ΑΥΤΟΜΑΤΕΣ
ΑΣΦΑΛΕΙΕΣ ΚΑΙ ΜΙΚΡΟΥΣ ΔΙΑΚΟΠΤΕΣ
H 90 x W 90mm



ΠΙΝΑΚΑΣ ΑΛΟΥΜΙΝΙΟΥ

15.011 6 ΧΡΩΜΙΟΜΕΝΟΙ ΔΙΑΚΟΠΤΕΣ
H 155 x W 115cm

15.012 3 ΧΡΩΜΙΟΜΕΝΟΙ ΔΙΑΚΟΠΤΕΣ
H 63 x W 115cm



ΠΙΝΑΚΑΣ ΜΕ LED

15.051 6 ΘΕΣΕΩΝ H170xW100mm

15.052 4 ΘΕΣΕΩΝ H125xW100mm

15.053 3 ΘΕΣΕΩΝ H102xW100mm



ΠΙΝΑΚΑΣ ΣΤΕΝΟΣ

15.068 3 ΔΙΑΚΟΠΤΕΣ H94 x W70mm

15.042 4 ΔΙΑΚΟΠΤΕΣ H120 x W70mm

15.067 5 ΔΙΑΚΟΠΤΕΣ H171 x W70mm
ΜΕ ΠΡΙΖΑ ΑΝΑΠΤΗΡΑ



15.002
ΠΙΝΑΚΑΣ ΑΛΟΥΜΙΝΙΟΥ ΜΕ ΦΩΤΑΚΙ
ΕΝΔΕΙΞΗ ΜΠΑΤΑΡΙΑΣ ΚΑΙ ΠΡΙΖΑ
ΑΝΑΠΤΗΡΑ / H 165 x W 115mm



15.062
ΠΙΝΑΚΑΣ ΜΕ ΕΝΔΕΙΞΗ
ΜΠΑΤΑΡΙΑΣ



15.034
ΠΙΝΑΚΑΣ ΑΛΟΥΜΙΝΙΟΥ
ΜΕ ΦΩΤΑΚΙ 2 ΘΕΣΕΩΝ



15.061
ΠΙΝΑΚΑΣ ΑΝΤΛΙΑΣ ΣΕΝΤΙΝΑΣ
H 83 x W 63mm



95.108
ΔΙΑΚΟΠΤΗΣ
ΑΔΙΑΒΡΟΧΟΣ ΜΕ LED
3P ON-OFF



95.107
ΚΑΠΑΚΙ ΣΙΛΙΚΟΝΗΣ
ΑΥΤΟΜΑΤΗΣ
ΑΣΦΑΛΕΙΑΣ



ΑΣΦΑΛΕΙΑ ΑΥΤΟΜΑΤΗ
95.106 2P-10A
95.110 2P-15A
95.111 2P-20A
95.112 2P-30A



95.131
ΔΙΑΚΟΠΤΗΣ
ΑΝΤ/ΚΟΣ
ΓΙΑ ΠΙΝΑΚΑ
ON-OFF 3P



95.210
ΔΙΑΚΟΠΤΗΣ
ON-OFF
(15.011-2)



ΔΙΑΚΟΠΤΗΣ ΦΩΤΙΖΟΜΕΝΟΣ
95.101 - ON-OFF
95.104 - ON-OFF-ON
95.109 - (ON)-OFF
95.100 -ON-OFF (ON)
95.105 - ΚΑΠΑΚΙ ΔΙΑΚΟΠΤΗ
ΣΙΛΙΚΟΝΗΣ ΔΙΑΦΑΝΕΣ



**ΔΙΑΚΟΠΤΗΣ ON-OFF
ΜΕ LED ΕΝΔΕΙΞΗ**
95.301 ΜΠΛΕ
95.302 ΠΡΑΣΙΝΟΣ
95.303 ΚΟΚΚΙΝΟΣ



**ΔΙΑΚΟΠΤΗΣ
ΤΥΠΟΥ CARLING**
95.305 ON-OFF
95.306 (ON)-OFF-(ON)
95.307 (ON)-OFF
95.308 ON-OFF-ON
95.309 ON-OFF-(ON)



**ΘΗΚΗ ΔΙΑΚΟΠΤΗ
ΤΥΠΟΥ CARLING**
95.311 ΑΚΡΗ
95.312 ΜΕΣΗ
95.313 ΜΟΝΗ



95.315
ΑΥΤΟΚΟΛΛΗΤΑ
ΤΥΠΟΥ CARLING



NEW

ΚΩΔΙΚΟΣ	ΛΕΙΤΟΥΡΓΙΑ	VOLT	A	LED
95.234A	ON-OFF	12V	5	■
95.235A	(ON)-OFF (momentary)	12V	5	■
95.234B	ON-OFF	12V	5	■
95.235B	(ON)-OFF (momentary)	12V	5	■
95.236A	ON-OFF	12V	15	■
95.237A	(ON)-OFF (momentary)	12V	15	■
95.236B	ON-OFF	12V	15	■
95.237B	(ON)-OFF (momentary)	12V	15	■



14.142
ΔΙΑΚΟΠΤΗΣ ΜΠΡΟΥΤΖΙΝΟΣ
ΚΟΡΝΑΣ



95.115
ΚΑΠΑΚΙ ΣΙΛΙΚΟΝΗΣ
ΜΑΥΡΟ



ΔΙΑΚΟΠΤΗΣ ΜΠΡΟΥΤΖΙΝΟΣ
14.131 2 ΘΕΣΕΩΝ
14.132 3 ΘΕΣΕΩΝ
14.133 4 ΘΕΣΕΩΝ



14.247
ΔΙΑΚΟΠΤΗΣ ΜΙΖΑΣ ΜΕ ΚΑΠΑΚΙ
3 ΘΕΣΕΩΝ

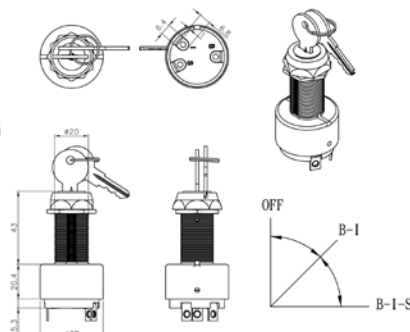



14.143
ΠΡΙΖΑ ΑΝΑΠΤΗΡΑ
ΕΝΙΣΧΥΜΕΝΗ



14.161
ΠΡΙΖΑ ΙΝΟΧ ΜΕ ΙΝΟΧ
ΑΝΑΠΤΗΡΑ



14.172
ΠΡΙΖΑ ΜΕ USB-C



93.078
ΠΡΙΖΑ ΕΞΩΤΕΡΙΚΗ
ΑΝΑΠΤΗΡΑ



14.177
ΠΡΙΖΑ ΑΝΑΠΤΗΡΑ ΜΙΚΡΗ
ΜΕ 2 ΘΥΡΕΣ USB



14.175
ΠΡΙΖΑ ΜΕ 2 ΘΥΡΕΣ USB
2 ΠΡΙΖΕΣ ΑΝΑΠΤΗΡΑ



14.198
ΠΡΙΖΑ ΑΝΑΠΤΗΡΑ ΑΡΣΕΝΙΚΗ
USB-TYPE C



14.176
ΠΡΙΖΑ ΑΝΑΠΤΗΡΑ ΜΕΓΑΛΗ
ΜΕ 2 ΘΥΡΕΣ USB



14.185
ΠΡΙΖΑ ΧΩΝΕΥΤΗ
ΑΝΑΠΤΗΡΑΣ-ΘΥΡΑ USB-C



14.186
ΠΡΙΖΑ ΕΠΙΚΑΘΗΜΕΝΗ
ΜΕ ΘΥΡΑ USB-C



14.187
ΠΡΙΖΑ ΕΠΙΚΑΘΗΜΕΝΗ
ΑΝΑΠΤΗΡΑΣ - ΘΥΡΑ USB-C



14.141
ΠΡΙΖΑ ΑΝΑΠΤΗΡΑ ΑΡΣΕΝΙΚΗ
ΕΝΙΣΧΥΜΕΝΗ



14.165
ΠΡΙΖΑ ΧΩΝΕΥΤΗ
ΑΝΑΠΤΗΡΑ -ΒΟΛΤΟΜΕΤΡΟ



14.180
ΠΡΙΖΑ ΧΩΝΕΥΤΗ
USB-C - ΒΟΛΤΟΜΕΤΡΟ



14.167
ΨΗΦΙΑΚΟ ΒΟΛΤΟΜΕΤΡΟ-
ΑΜΠΕΡΟΜΕΤΡΟ



14.168
ΨΗΦΙΑΚΟ
ΒΟΛΤΟΜΕΤΡΟ



14.153
ΠΡΙΖΑ ΑΝΑΠΤΗΡΑ
ΦΩΤΙΖΟΜΕΝΗ



14.179
ΠΡΙΖΑ USB ΤΥΠΟΥ CARLING



14.169
ΠΡΙΖΑ ΧΩΝΕΥΤΗ USB-AMP-VOLT



14.163
ΠΡΙΖΑ ΧΩΝΕΥΤΗ ΦΩΤΙΖΟΜΕΝΗ
USB+ΒΟΛΤΟΜΕΤΡΟ ΚΟΚΚΙΝΗ



14.164
ΠΡΙΖΑ ΦΩΤΙΖΟΜΕΝΗ ΔΙΠΛΗ
USB + ΒΟΛΤΟΜΕΤΡΟ



14.171 ΘΗΛΥΚΗ
14.173 ΑΡΣΕΝΙΚΗ



ΤΕΡΜΑΤΙΚΟ ΑΚΡΟΔΕΚΤΩΝ ΜΟΝΟ Β Τ

- 14.149 6mm
- 14.144 8mm
- 14.154 10mm



14.146

ΤΕΡΜΑΤΙΚΟ ΑΚΡΟΔΕΚΤΩΝ 6 ΘΕΣΕΩΝ ΒΑΡΕΩΣ ΤΥΠΟΥ



ΤΕΡΜΑΤΙΚΟ ΑΚΡΟΔΕΚΤΩΝ

- 14.150 4 ΘΕΣΕΩΝ
- 14.151 6 ΘΕΣΕΩΝ
- 14.152 8 ΘΕΣΕΩΝ



14.145

ΤΕΡΜΑΤΙΚΟ ΑΚΡΟΔΕΚΤΩΝ 4 ΘΕΣΕΩΝ ΒΑΡΕΩΣ ΤΥΠΟΥ



14.147 ΤΕΡΜ/ΚΟ ΑΚΡΟΔΕΚΤΩΝ 10 ΘΕΣΕΩΝ

14.148 ΤΕΡΜ/ΚΟ ΑΚΡΟΔΕΚΤΩΝ 12 ΘΕΣΕΩΝ



ΜΠΑΡΑ ΑΚΡΟΔΕΚΤΩΝ ΜΕ ΚΑΠΑΚΙ

- 14.155 M6x4
- 14.156 M4x6
- 14.157 M4x12



14.196

ΠΡΙΖΑ ΣΚΑΦΟΥΣ ΘΗΛΥΚΗ ΙΝΟΧ



14.188

ΠΡΙΖΑ ΣΚΑΦΟΥΣ ΘΗΛΥΚΗ IP56 ΜΕ ΠΛΑΣΤΙΚΟ ΚΑΠΑΚΙ



ΠΡΙΖΑ ΚΑΤΑΣΤΡΩΜΑΤΟΣ ΙΝΟΧ

- | | | |
|--------|----------|----|
| 14.181 | 2 ΘΕΣΕΩΝ | 3A |
| 14.182 | 3 ΘΕΣΕΩΝ | 3A |
| 14.183 | 4 ΘΕΣΕΩΝ | 3A |
| 14.191 | 2 ΘΕΣΕΩΝ | 5A |
| 14.192 | 3 ΘΕΣΕΩΝ | 5A |
| 14.193 | 4 ΘΕΣΕΩΝ | 5A |



NEW

ΠΡΙΖΑ ΣΚΑΦΟΥΣ ΑΡΣΕΝΙΚΗ

- 14.184 3 PIN 16A 230V
- 14.299 3 PIN 32A 230V



NEW

- 14.294 PIN 16A 230V OSC
- 14.195 PIN 32A 230V OSC



14.190

ΚΑΛΥΜΑ ΠΡΙΖΑΣ ΣΚΑΦΟΥΣ ΜΠΛΕ



14.189

ΠΡΙΖΑ ΣΚΑΦΟΥΣ ΑΡΣΕΝΙΚΗ ΜΠΛΕ 16A



14.194

ΠΡΙΖΑ ΣΚΑΦΟΥΣ ΜΕ ΚΑΛΩΔΙΟ 10mt 16A



14.296 ΠΡΙΖΑ ΣΚΑΦΟΥΣ ΘΗΛΥΚΗ ΜΠΛΕ 3PIN 16A 230V IP44

14.297 ΠΡΙΖΑ ΣΚΑΦΟΥΣ ΘΗΛΥΚΗ ΜΠΛΕ 3PIN 32A 230V



14.291

ΠΡΙΖΑ ΣΚΑΦΟΥΣ ΑΡΣΕΝΙΚΗ ΜΠΛΕ 3PIN 16A 230V IP44



14.292

ΠΡΙΖΑ ΣΚΑΦΟΥΣ ΑΡΣΕΝΙΚΗ ΜΠΛΕ 3PIN 32A 230V IP44



14.293

ΠΡΙΖΑ ΣΚΑΦΟΥΣ ΑΡΣΕΝΙΚΗ ΚΟΚΚΙΝΗ 5PIN 63A 230V



14.298

ΠΡΙΖΑ ΣΚΑΦΟΥΣ ΘΗΛΥΚΗ ΚΟΚΚΙΝΗ 5PIN 63A 230V



**ΠΛΑΦΟΝΙΕΡΑ INOX
ΜΕ ΔΙΑΚΟΠΤΗ**

14.031 3"
14.032 4"
14.033 5"



**ΠΛΑΦΟΝΙΕΡΑ INOX LED
ΜΕ ΔΙΑΚΟΠΤΗ**

14.230 3"
14.231 4"
14.232 5"



**14.053
ΠΛΑΦΟΝΙΕΡΑ
ΜΠΡΟΥΤΖΙΝΗ 5"**



**96.485
ΠΛΑΦΟΝΙΕΡΑ ΣΤΕΝΗ
LED INOX TOUCH BUTTON
Φ105cm**



**14.055 - ΠΛΑΦΟΝΙΕΡΑ ΕΣΩΤΕΡΙΚΗ
ΧΡΩΜΙΟΥ ΜΕ ΚΟΥΜΠΙ (BAVARIA)**

**14.056 - ΠΛΑΦΟΝΙΕΡΑ ΕΣΩΤΕΡΙΚΗ
ΧΡΩΜΙΟΥ LED ΜΕ ΚΟΥΜΠΙ (BAVARIA)**

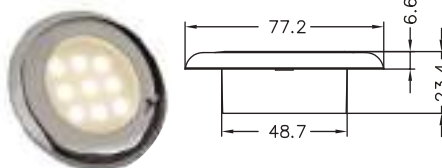

**ΠΛΑΦΟΝΙΕΡΑ ΧΡΩΜΙΟΥ
ΜΕ ΔΙΑΚΟΠΤΗ**

**14.261 ΦΘΟΡΙΟΥ 80mm
14.262 LED 80mm**



**14.257
ΠΛΑΦΟΝΙΕΡΑ ΣΤΕΝΗ 3LED /
SPLASHPROOF 75mm**



**14.255
ΠΛΑΦΟΝΙΕΡΑ LED ΑΔΙΑΒΡΟΧΗ
IP 65 ΣΤΕΝΗ 6 LED**



**14.251
ΠΛΑΦΟΝΙΕΡΑ LED ΑΔΙΑΒΡΟΧΗ
IP 65 ΣΤΕΝΗ 5 LED**

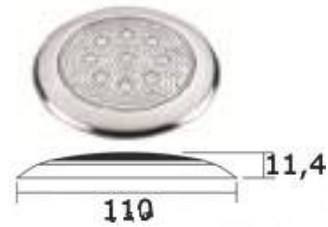

**14.249
ΠΛΑΦΟΝΙΕΡΑ LED ΑΔΙΑΒΡΟΧΗ
IP 65 ΣΤΕΝΗ 6 LED**



**ΠΛΑΦΟΝΙΕΡΑ ΜΕ ΔΙΑΚΟΠΤΗ
14.264 ΧΡΩΜΙΟΥ LED 10-30V 80mm NEO
14.265 ΛΕΥΚΗ LED 10-30V 80mm NEO**

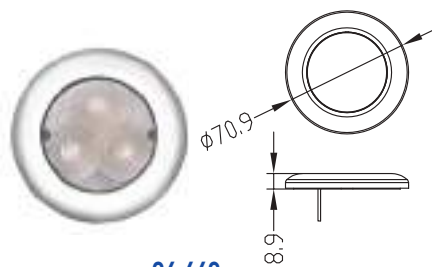

**96.442
ΠΛΑΦΟΝΙΕΡΑ ΣΤΡΟΓΓΥΛΗ
ΧΩΝΕΥΤΗ LED 80mm ΤΡΥΠΑ 50mm
SPLASHPROOF INOX**



**14.075
ΠΛΑΦΟΝΙΕΡΑ LED 70CM**



**14.076
ΠΛΑΦΟΝΙΕΡΑ LED 80CM**



96.441
ΠΛΑΦΟΝΙΕΡΑ ΕΣΩΤΕΡΙΚΗ
ΧΩΝΕΥΤΗ ΜΙΚΡΗ LED
SPLASHPROOF



14.266
ΠΛΑΦΟΝΙΕΡΑ LED 10-30V
250x70mm ΜΑΚΡΟΣΤΕΝΗ



99.050
ΠΛΑΦΟΝΙΕΡΑ 4 LED
190x30mm



14.267
ΠΛΑΦΟΝΙΕΡΑ LED 12V
ΣΤΡΟΓΓΥΛΗ ΜΙΣΟΣ ΦΩΤΙΣΜΟΣ Φ42mm
A: ΛΕΥΚΟ B: ΜΠΛΕ

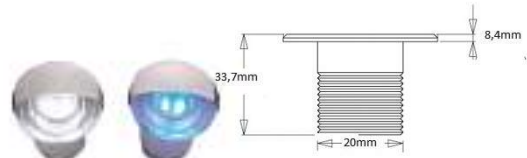

14.268
ΠΛΑΦΟΝΙΕΡΑ LED 12V
ΙΝΟΧ ΜΙΣΟΣ ΦΩΤΙΣΜΟΣ
A: ΛΕΥΚΟ B: ΜΠΛΕ

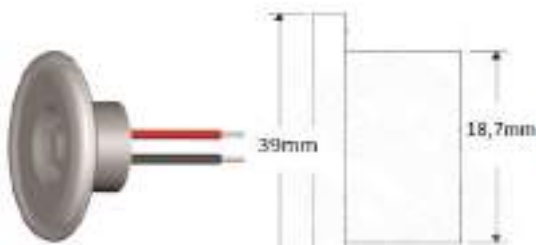
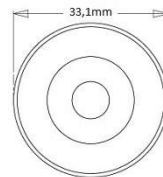

96.484
ΠΛΑΦΟΝΙΕΡΑ ΣΤΕΝΗ LED
ΑΔΙΑΒΡΟΧΗ ΤΡΥΠΑ



14.269
ΠΛΑΦΟΝΙΕΡΑ LED 10-30V
200x60mm



ΠΛΑΦΟΝΙΕΡΑ ΣΤΕΝΗ inox LED 12V ΣΤΡΟΓΓΥΛΗ ΚΑΤΩ
14.092A ΛΕΥΚΟ 14.092B ΜΠΛΕ



14.287
ΠΛΑΦΟΝΙΕΡΑ LED
RGBW SPLASPROOF
Φ78 ΤΡΥΠΑ Φ50

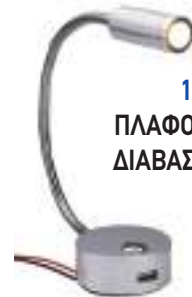

14.040
ΠΛΑΦΟΝΙΕΡΑ LED
ΔΙΑΒΑΣΜΑΤΟΣ 12V
USB



96.410
ΠΛΑΦΟΝΙΕΡΑ ΑΔΙΑΒΡΟΧΗ
ΓΙΑ ΡΟΛ ΜΠΑΡ
ΜΕ ΔΙΑΚΟΠΤΗ IP66



TAINIA LED SMD5050
60SMD/MTR

14.252 COOL WHITE

14.253 WARM WHITE



TAINIA NEON FLEX 12V

14.260A ΘΕΡΜΟ

14.260B ΨΥΧΡΟ



14.107
ΦΩΤΙΣΤΙΚΟ ΤΡΑΠΕΖΙΟΥ
ΜΕ ΠΡΙΖΑ 12V 10W
180x340mm



14.109
ΦΩΤΙΣΤΙΚΟ
ΤΡΑΠΕΖΙΟΥ
LED

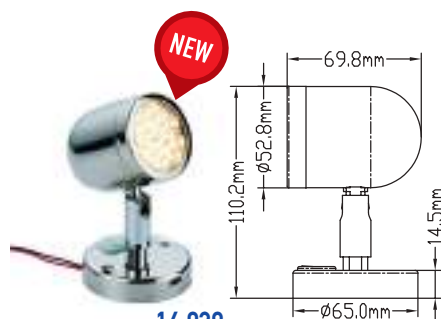

14.039
ΠΛΑΦΟΝΙΕΡΑ ΕΠΙΤΟΙΧΙΑ INOX
USB 10-30V



ΠΛΑΦΟΝΙΕΡΑ ΦΘΟΡΙΟΥ ΔΙΠΛΗ 12V
14.112 ΧΩΝΕΥΤΗ
14.114 ΕΠΙΦΑΝΕΙΑΣ
L 410 X W 95mm



14.111
ΠΛΑΦΟΝΙΕΡΑ ΜΟΝΗ
ΦΘΟΡΙΟΥ
L 380 x W 60mm



14.113
ΠΛΑΦΟΝΙΕΡΑ ΜΟΝΗ
LED 12V L400xW65mm



14.282
ΠΛΑΦΟΝΙΕΡΑ TOUCH LED 10-30V
173mm(L) x 56.9mm (W)



14.281
ΠΛΑΦΟΝΙΕΡΑ TOUCH LED ΜΕ DIMMER
10-30V 255.0mm(L) x 45.0mm(W)



14.283
ΠΛΑΦΟΝΙΕΡΑ TOUCH LED
10-30V 300mm(L) x 56.9mm(W)



14.108
ΒΑΣΗ ΦΩΤΙΣΤΙΚΟΥ
ΤΡΑΠΕΖΙΟΥ



14.038
ΑΠΛΙΚΑ INOX
ΚΑΜΠΙΝΑΣ LED

ΛΑΜΠΑΚΙΑ LED



ΚΩΔΙΚΟΣ	ΤΥΠΟΣ	LED	ΕΠΑΦΗ	W	VOLt	ΔΙΑΣΤΑΣΗ	ΧΡΩΜΑ
99.224	G4	12	ΠΙΣΩ	2,5	10-30	31mm	WARMWHITE
99.225	G4	12	ΠΛΑΙ	2,5	10-30	31mm	WARMWHITE
99.226	G4 ΣΤΕΝΟ	15	ΣΤΕΝΟ	1,4	10-30	21mmX15mm	WARMWHITE
99.227	G4	6	ΠΛΑΙ	1,8	10-30	23mm	WARMWHITE
99.228	G4	6	ΠΙΣΩ	1,8	10-30	23mm	WARMWHITE
99.229	G4	9	ΠΛΑΙ	1,8	10-30	28mm	WARMWHITE
99.230	G4	9	ΠΙΣΩ	1,8	10-30	28mm	WARMWHITE
99.221	FESTOON	6	2	1	12	41mm	WARMWHITE
99.231	FESTOON	6	2	1	12	30mm	WARMWHITE
99.232	FESTOON	6	2	1	12	38mm	WARMWHITE
99.233	ΠΕΡΙΒΛΕΠΤΟ	13	2ΡΙΝ/ΠΑΡΑΛΛΗΛΑ		12		WARM WHITE
99.234	ΠΕΡΙΒΛΕΠΤΟ	13	2ΡΙΝ/ΜΗ ΠΑΡΑΛΛΗΛΑ		12		WARM WHITE
99.235	ΠΕΡΙΒΛΕΠΤΟ	18	2ΡΙΝ/ΠΑΡΑΛΛΗΛΑ		12		WARM WHITE
99.236	ΠΕΡΙΒΛΕΠΤΟ	18	2ΡΙΝ/ΜΗ ΠΑΡΑΛΛΗΛΑ		12		WARM WHITE



**ΠΡΟΒΟΛΕΑΣ ΑΣΥΡΜΑΤΟΣ LED
10-30V 28W**

15.087 ΛΕΥΚΟΣ / 15.087B ΜΑΥΡΟΣ

- 360° Horizontal rotation
- 60° Vertical sweep
- 2700LM super bright LED light source
- 300-400 Meters beam distance
- Waterproof grade IP65
- Remote control and 15 ft. cable included
- ASA material, corrosion-resistant, oxidation-resistant
- Long service life
- Easy installation



**15.457
ΠΡΟΒΟΛΕΑΣ
ΑΣΥΡΜΑΤΟΣ
12V 100W**

- 360° Horizontal rotation
- 60° Vertical sweep
- 420 Meters beam distance
- Waterproof grade IP65
- High output halogen sealed beam lamp
- Remote control and 15 ft. cable included
- ASA material, corrosion-resistant, oxidation-resistant
- Easy installation
- CANDLE POWER 200000cd



**15.458
ΠΡΟΒΟΛΕΑΣ
ΑΣΥΡΜΑΤΟΣ
12V 50W**

- 360° Horizontal rotation
- 75° Vertical sweep
- 262 Meters beam distance
- Waterproof grade IP65
- High output halogen sealed beam lamp
- Remote control and 15 ft. cable included
- ASA material, corrosion-resistant, oxidation-resistant
- Easy installation
- CANDLE POWER 100000cd



**15.459
ΠΡΟΒΟΛΕΑΣ
ΑΣΥΡΜΑΤΟΣ
ΜΙΚΡΟΣ
12V 50W**

- 360° Horizontal rotation
- 60° Vertical sweep
- 386 Meters beam distance
- Waterproof grade IP65
- High output halogen sealed beam lamp
- Remote control and 15 ft. cable included
- ASA material, corrosion-resistant, oxidation-resistant
- Easy installation
- CANDLE POWER 175000cd



**ΠΡΟΒΟΛΕΑΣ ΑΔΙΑΒΡΟΧΟΣ
LED ΜΕ ΧΕΙΡΙΣΤΗΡΙΟ
15.081 12V / 15.085 24V**



**15.084
ΠΡΟΒΟΛΕΑΣ
ΑΣΥΡΜΑΤΟΣ
ΑΔΙΑΒΡΟΧΟΣ
12x3W LED
10-30V 1600LM**



**15.082
ΠΡΟΒΟΛΕΑΣ ΑΣΥΡΜΑΤΟΣ
ΑΔΙΑΒΡΟΧΟΣ 12V 50W**



**15.083
ΠΡΟΒΟΛΕΑΣ ΑΣΥΡΜΑΤΟΣ
10x5W LED ΑΔΙΑΒΡΟΧΟΣ
12V IP65 4000LM**



**15.086 ΠΡΟΒΟΛΕΑΣ LED ΤΗΛΕΧ/ΝΟΣ
15.086B ΠΡΟΒΟΛΕΑΣ LED ΤΗΛΕΧ/ΝΟΣ 24V**



**15.073
ΠΡΟΒΟΛΕΑΣ ΑΔΙΑΒΡΟΧΟΣ ΓΙΑ
ΡΕΛΙΑ ΑΠΟΣΤΑΣΗΣ 130m 12V**



**ΑΝΤΑΛΛ/ΚΗ ΛΑΜΠΑ
ΑΛΟΓΟΝΟΥ ΠΡΟΒΟΛΕΑ
15.078A 12V
15.078B 24V**



**15.075
ΠΡΟΒΟΛΕΑΣ ΙΝΟΧ
ΜΕ ΠΕΡΙΣΤΡΟΦΙΚΗ
ΒΑΣΗ 12V**



**15.074
ΠΡΟΒΟΛΕΑΣ
ΑΔΙΑΒΡΟΧΟΣ
ΒΑΣΕΩΣ ΛΕΥΚΟΣ
ΑΠΟΣΤΑΣΗΣ
130m 12v**



**14.102
ΠΡΟΒΟΛΕΑΣ ΜΕΤΑΒΛΗΤΟΣ
ΙΣΤΟΥ ΙΝΟΧ 12V**



**14.101
ΠΡΟΒΟΛΕΑΣ ΣΤΑΘΕΡΟΣ
ΙΣΤΟΥ ΙΝΟΧ 12V**



15.235
ΠΡΟΒΟΛΕΑΣ ΕΛΑΣΤΙΚΟΣ
ΜΙΚΡΟΣ ΜΕ ΠΡΙΖΑ
ΑΝΑΠΗΡΑ 12V



15.112
ΠΡΟΒΟΛΕΑΣ ΕΛΑΣΤΙΚΟΣ
ΜΕΓΑΛΟΣ 12V



15.111
ΠΡΟΒΟΛΕΑΣ ΕΛΑΣΤΙΚΟΣ
ΜΕΣΑΙΟΣ 12V



14.091
ΜΠΑΛΑΝΤΕΖΑ
ΕΡΓΑΣΙΑΣ 12V



15.257
ΠΡΟΒΟΛΕΑΣ LED 5x5W
10-30V



15.267
ΠΡΟΒΟΛΕΑΣ LED 4x5W
10-30V



15.256
ΠΡΟΒΟΛΕΑΣ 6x3W LED
ΑΔΙΑΒΡΟΧΟΣ IP66 560LM 9-56V



15.265
ΠΡΟΒΟΛΕΑΣ ΑΔΙΑΒΡΟΧΟΣ
4x3W LED 900LM 10-30V



15.178
ΠΡΟΒΟΛΕΑΣ ΦΑΚΟΣ USB
ΛΙΘΙΥΜ -ΑΔΙΑΒΡΟΧΟΣ
IP67-500LM



15.269
ΠΡΟΒΟΛΕΑΣ ΣΤΕΝΟΣ 6LED
680LM ΙΝΟΧ ΒΑΣΗ ΛΕΥΚΟΣ
10-30V 6x3W



ΠΡΟΒΟΛΕΑΣ ΣΤΕΝΟΣ SPOT
ΦΩΤΙΣΜΟΣ 1200LM 9-60V 6x3W
15.279A ΛΕΥΚΟΣ
15.279B ΜΑΥΡΟΣ

ΥΠΟΒΡΥΧΙΟΣ ΦΩΤΙΣΜΟΣ

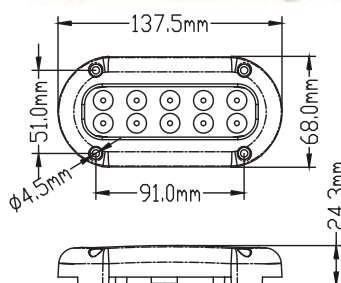

ΦΩΣ ΥΠΟΒΡΥΧΙΟ 10LED ΛΕΥΚΟ ΠΑΡΑΛ/ΜΟ
1130LM IP68 10-30V L137xW68xH24mm
14.280A ΛΕΥΚΟ **14.280B** ΜΠΛΕ

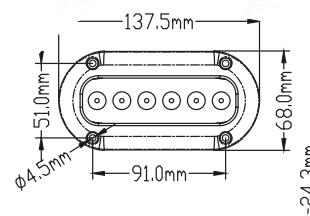

ΦΩΣ ΥΠΟΒΡΥΧΙΟ 6x3W LED IP68
10-30V 670LM L137xW68xH24mm
14.278A ΛΕΥΚΟ **14.278B** ΜΠΛΕ



ΦΩΣ ΥΠΟΒΡΥΧΙΟ 3x3W LED 460LM
 10-30V L96 x W59mm
 14.254 ΛΕΥΚΟ 14.256 ΜΠΛΕ

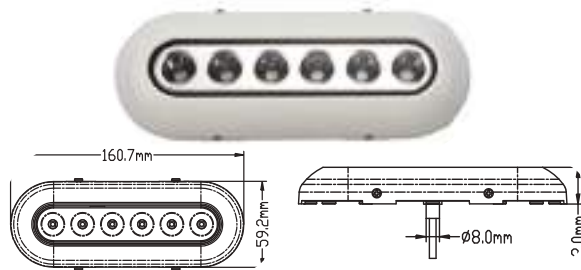

ΦΩΣ ΥΠΟΒΡΥΧΙΟ 6x3W LED 710LM 10-30V
 L160 x W60mm
 14.258 ΛΕΥΚΟ 14.259 ΜΠΛΕ



14.286
ΦΩΣ ΥΠΟΒΡΥΧΙΟ 9 LED IP68
 RGBW10-30V 160L*78W*24H



ΦΩΣ ΥΠΟΒΡΥΧΙΟ INOX 6x3W LED
 10-30V LED Φ90mm 560LM
 14.248 ΛΕΥΚΟ 14.250 ΜΠΛΕ



14.279
ΦΩΣ ΥΠΟΒΡ. ΛΕΥΚΟ ΣΤΡΟΓΓΥΛΟ
 ΟΙΚΟΝΟΜΙΚΟ 10-30V 560L 6LED IP68



ΦΩΣ ΥΠΟΒΡΥΧΙΟ ΣΤΡΟΓΓΥΛΟ INOX
 LED 10-30V Φ120mm 1100LM
 14.274 ΜΠΛΕ 14.275 ΛΕΥΚΟ



ΦΩΣ ΥΠΟΒΡΥΧΙΟ INOX 9x3W LED
 10-30V LED Φ90mm 995LM
 14.276 ΛΕΥΚΟ 14.277 ΜΠΛΕ



14.285
ΦΩΣ ΥΠΟΒΡΥΧΙΟ ΜΟΝΟ 4W
 600 LUMEN RGBW 10-30V



14.288
ΦΩΣ ΥΠΟΒΡΥΧΙΟ RGB 50
 Φ100x18mm 50W 5000 LM



ΦΩΣ ΥΠΟΒΡΥΧΙΟ STAR 50
 Φ100x18mm 50W 5000 LM
 14.289A ΛΕΥΚΟ
 14.289B ΜΠΛΕ



14.290
ΦΩΣ ΥΠΟΒΡΥΧΙΟ
 CHARTER COOL WHITE 30
 Φ100x18mm 30W 3000 LM



ΦΩΣ ΥΠΟΒΡΥΧΙΟ ΣΤΕΝΟ INOX
 LED 10-30V 95x40mm 100LM
 14.270 ΜΠΛΕ 14.271 ΛΕΥΚΟ

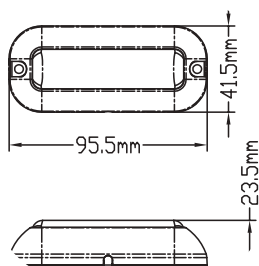

ΦΩΣ ΥΠΟΒΡΥΧΙΟ ΣΤΕΝΟ INOX
 218LM LED 10-30V 120x40mm
 14.272 ΜΠΛΕ 14.273 ΛΕΥΚΟ

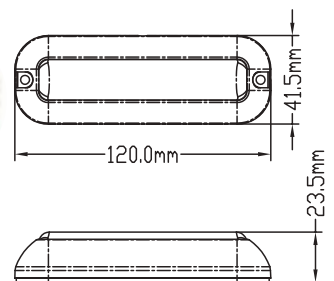



14.234
ΦΑΝΟΣ ΠΛΕΥΡΙΚΟΣ ΙΝΟΧ
ΚΟΚΚΙΝΟΣ



14.235
ΦΑΝΟΣ ΠΛΕΥΡΙΚΟΣ ΙΝΟΧ
ΠΡΑΣΙΝΟΣ



14.237 - ΦΑΝΟΣ ΙΝΟΧ ΚΟΡΩΝΗΣ
14.236 - ΦΑΝΟΣ ΙΝΟΧ ΕΦΙΣΤΙΟΣ



14.238
ΦΑΝΟΣ ΠΛΕΥΡΙΚΟΣ ΟΒΑΛ
ΙΝΟΧ ΚΟΚΚΙΝΟΣ



14.239
ΦΑΝΟΣ ΠΛΕΥΡΙΚΟΣ ΟΒΑΛ
ΙΝΟΧ ΠΡΑΣΙΝΟΣ



14.241 - ΦΑΝΟΣ ΙΝΟΧ ΟΒΑΛ ΕΦΙΣΤΙΟΣ
14.240 - ΦΑΝΟΣ ΙΝΟΧ ΟΒΑΛ ΚΟΡΩΝΗΣ



14.242
ΦΑΝΟΣ ΟΒΑΛ ΠΛΕΥΡΙΚΟΣ
ΚΟΚΚΙΝΟΣ
Α ΛΕΥΚΟ / Β ΜΑΥΡΟ



14.243
ΦΑΝΟΣ ΟΒΑΛ ΠΛΕΥΡΙΚΟΣ
ΠΡΑΣΙΝΟΣ
Α ΛΕΥΚΟ / Β ΜΑΥΡΟ



14.244 - ΦΑΝΟΣ ΟΒΑΛ ΕΦΙΣΤΙΟΣ
14.245 - ΦΑΝΟΣ ΟΒΑΛ ΚΟΡΩΝΗΣ
Α ΛΕΥΚΟ / Β ΜΑΥΡΟ



14.011
ΦΑΝΟΣ ΕΦΙΣΤΙΟΣ
ΙΤΑΛΙΑΣ
Α ΛΕΥΚΟ / Β ΜΑΥΡΟ



14.012
ΦΑΝΟΣ ΚΟΡΩΝΗΣ
ΙΤΑΛΙΑΣ
Α ΛΕΥΚΟ / Β ΜΑΥΡΟ



14.015
ΦΑΝΟΣ ΔΙΠΛΟΣ
ΚΟΚΚΙΝΟΣ-ΠΡΑΣΙΝΟΣ ΙΤΑΛΙΑΣ
Α ΛΕΥΚΟ / Β ΜΑΥΡΟ



14.014
ΦΑΝΟΣ ΠΛΕΥΡΙΚΟΣ ΠΡΑΣΙΝΟΣ
ΙΤΑΛΙΑΣ
Α ΛΕΥΚΟ / Β ΜΑΥΡΟ



14.013
ΦΑΝΟΣ ΠΛΕΥΡΙΚΟΣ
ΚΟΚΚΙΝΟΣ ΙΤΑΛΙΑΣ
Α ΛΕΥΚΟ / Β ΜΑΥΡΟ



14.223
ΦΑΝΟΣ ΠΕΡΙΒΛΕΠΤΟΣ
ΛΕΥΚΟΣ ΙΝΟΧ
14.263
ΦΑΝΟΣ ΠΕΡΙΒΛΕΠΤΟΣ
ΛΕΥΚΟΣ ΙΝΟΧ LED



ΦΑΝΟΣ ΜΕ ΛΑΜΑΚΙ ΙΝΟΧ

- 14.009 ΠΛΕΥΡΙΚΟΣ ΚΟΚΚΙΝΟΣ
- 14.010 ΠΛΕΥΡΙΚΟΣ ΠΡΑΣΙΝΟΣ
- 14.007 ΕΦΙΣΤΙΟΣ
- 14.008 ΚΟΡΩΝΗΣ



14.024
ΦΑΝΑΡΑΚΙ 3 ΘΕΣΕΩΝ ΜΠΑΤΑΡΙΑΣ
ΛΕΥΚΟ-ΚΟΚΚΙΝΟ-ΠΡΑΣΙΝΟ



14.025
ΦΑΝΑΡΑΚΙ 3 ΘΕΣΕΩΝ
LED ΜΠΑΤΑΡΙΑΣ

14.054
ΙΣΤΟΣ ΜΠΑΤΑΡΙΑΣ
ΜΕ ΒΕΝΤΟΥΖΑ



14.060
ΦΑΝΟΣ ΝΑΥΣΙΠΛΟΙΑΣ LED
ΠΡΑΣ-ΚΟΚ-ΛΕΥΚΟΣ ΜΕ
ΜΠΑΤΑΡΙΑ



96.447
ΦΑΝΟΣ ΚΟΡΩΝΗΣ
LED 80mm



14.035
ΦΑΝΟΣ ΙΝΟΧ ΕΠΙΚ/ΝΟΣ
ΔΙΠΛΟΣ ΠΡΑΣ-ΚΟΚ LED

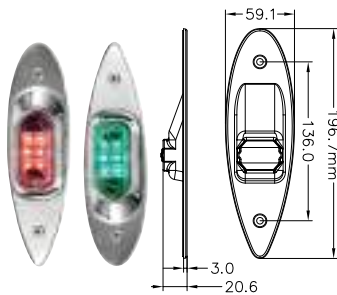

14.027
ΦΑΝΟΣ ΧΩΝΕΥΤΟΣ
ΙΝΟΧ ΜΑΤΙ ΜΕ LED



14.023
ΦΑΝΟΣ ΧΩΝΕΥΤΟΣ
ΠΛΑΣΤΙΚΟΣ ΜΑΤΙ
Α-ΛΕΥΚΟ / Β-ΜΑΥΡΟ



14.022
ΦΑΝΟΣ ΧΩΝΕΥΤΟΣ
ΙΝΟΧ ΜΑΤΙ



14.034
ΦΑΝΟΣ ΙΝΟΧ ΕΠΙΚ/ΝΟΣ
ΠΡΑΣ-ΚΟΚ LED ΖΕΥΓΟΣ



ΦΑΝΟΣ ΕΠΙΚΑΘΗΜΕΝΟΣ
ΠΛΑΣΤΙΚΟΣ ΠΡΑΣΙΝΟΣ
80x58xH38mm

- 14.036 ΚΟΚΚΙΝΟΣ
- 14.037 ΠΡΑΣΙΝΟΣ



14.028
ΦΑΝΟΣ ΕΠΙΚΑ/ΝΟΣ ΙΝΟΧ LED
ΠΡΑΣΙΝΟ-ΚΟΚΚΙΝΟ (ΖΕΥΓΟΣ)



14.029
ΦΑΝΟΣ ΙΝΟΧ ΕΠΙΚ/ΝΟΣ
LED ΔΙΠΛΟΣ



14.021
ΦΑΝΟΣ ΠΛΩΡΗΣ
ΔΙΠΛΟΣ ΙΝΟΧ LED



14.016
ΦΑΝΟΣ ΠΕΡΙΒΛΕΠΤΟΣ
ΚΟΚΚΙΝΟΣ ΜΙΚΡΟΣ



14.017
ΦΑΝΟΣ ΠΕΡΙΒΛΕΠΤΟΣ
ΠΡΑΣΙΝΟΣ



14.018
ΦΑΝΟΣ ΠΕΡΙΒΛΕΠΤΟΣ
ΛΕΥΚΟΣ ΜΙΚΡΟΣ



14.018-1
ΦΑΝΟΣ ΠΕΡΙΒΛΕΠΤΟΣ
ΛΕΥΚΟΣ ΜΕΓΑΛΟΣ



14.016-1
ΦΑΝΟΣ ΠΕΡΙΒΛΕΠΤΟΣ
ΚΟΚΚΙΝΟΣ ΜΕΓΑΛΟΣ



96.425-A

ΦΑΝΟΣ ΠΛΑΙΝΟΣ ΛΕΥΚΟΣ LED
ΠΡΑΣΙΝΟΣ-ΚΟΚΚΙΝΟΣ ΛΕΥΚΗ ΒΑΣΗ

96.425-B

ΦΑΝΟΣ ΠΛΑΙΝΟΣ ΛΕΥΚΟΣ LED
ΠΡΑΣΙΝΟΣ-ΚΟΚΚΙΝΟΣ ΜΑΥΡΗ ΒΑΣΗ



96.426-A

ΦΑΝΟΣ ΠΛΑΙΝΟΣ ΙΝΟΧ LED
ΚΟΚΚΙΝΟΣ-ΠΡΑΣΙΝΟΣ ΛΕΥΚΗ ΒΑΣΗ

96.426-B

ΦΑΝΟΣ ΠΛΑΙΝΟΣ ΙΝΟΧ LED
ΚΟΚΚΙΝΟΣ-ΠΡΑΣΙΝΟΣ ΜΑΥΡΗ ΒΑΣΗ



14.026

ΦΑΝΟΣ ΠΛΑΙΝΟΣ LED
ΜΑΥΡΟΣ-ΚΟΚΚΙΝΟΣ-ΠΡΑΣΙΝΟΣ
(ΖΕΥΓΟΣ)



14.062

ΦΑΝΟΣ ΠΛΑΙΝΟΣ ΙΝΟΧ
ΠΡΑΣΙΝΟΣ ΚΟΚΚΙΝΟΣ ΝΕΜΟ 2

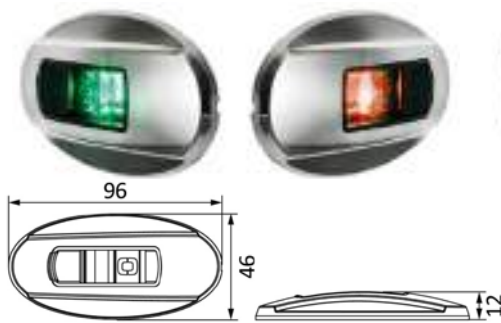

14.061

ΦΑΝΟΣ ΠΛΑΙΝΟΣ ΙΝΟΧ
ΠΡΑΣΙΝΟΣ ΚΟΚΚΙΝΟΣ ΝΕΜΟ 1



ΦΑΝΟΣ LED

14.041 - ΠΛΕΥΡΙΚΟΣ ΚΟΚΚΙΝΟΣ

14.042 - ΠΛΕΥΡΙΚΟΣ ΠΡΑΣΙΝΟΣ

14.043 - ΦΑΝΟΣ ΚΟΡΩΝΗΣ

14.044 - ΦΑΝΟΣ ΕΦΙΣΤΙΟΣ



14.067

ΙΣΤΟΣ ΤΡΙΧΡΩΜΟΣ RGB
ΜΕ ΠΑΝΕΛ
ΦΩΤΟΒΟΛΤΑΪΚΟ



14.068

ΙΣΤΟΣ ΣΤΡΟΓΓΥΛΟΣ
ΛΕΥΚΟΣ ΜΕ ΠΑΝΕΛ
ΦΩΤΟΒΟΛΤΑΪΚΟ



14.066

ΦΑΝΟΣ ΤΡΙΧΡΩΜΟΣ LED
ΜΕ ΠΑΝΕΛ
ΦΩΤΟΒΟΛΤΑΪΚΟ



96.461

ΦΑΝΟΣ ΠΕΡΙΒΛΕΠΤΟΣ
LED 8-30V 105x60mm



96.448-B

ΦΑΝΟΣ ΠΕΡΙΒΛΕΠΤΟΣ
ΛΕΥΚΟ LED
ΜΕ ΒΑΣΗ ΜΑΥΡΗ



96.448-A

ΦΑΝΟΣ ΠΕΡΙΒΛΕΠΤΟΣ
ΛΕΥΚΟ LED
ΜΕ ΒΑΣΗ ΛΕΥΚΗ



14.019

ΦΑΝΟΣ ΠΕΡΙΒΛΕΠΤΟΣ
ΜΕ ΒΑΣΗ ΜΑΥΡΗ

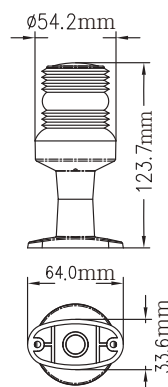



14.073
ΦΑΝΟΣ ΕΠΙΚΑΘΗΜΕΝΟΣ
ΔΙΠΛΟΣ ΛΕΥΚΟΣ LED



14.071
ΦΑΝΟΣ ΕΠΙΚΑΘΗΜΕΝΟΣ
ΔΙΠΛΟΣ LED



14.072
ΦΑΝΟΣ ΕΠΙΚΑΘΗΜΕΝΟΣ
ΚΟΚ-ΠΡΑΣ LED



14.069
ΦΑΝΟΣ ΠΛΑΙΝΟΣ
ΚΟΚ-ΠΡΑΣ LED



ΦΑΝΟΣ ΕΦΙΣΤΙΟΣ LED
14.401A ΛΕΥΚΟΣ
14.401B ΜΑΥΡΟΣ



ΦΑΝΟΣ ΚΟΡΩΝΗΣ LED
14.402A ΛΕΥΚΟΣ
14.402B ΜΑΥΡΟΣ



ΦΑΝΟΣ ΠΛΕΥΡΙΚΟΣ LED
ΚΟΚΚΙΝΟΣ
14.413A ΛΕΥΚΗ ΒΑΣΗ
14.413B ΜΑΥΡΗ ΒΑΣΗ



ΦΑΝΟΣ ΠΛΕΥΡΙΚΟΣ LED
ΠΡΑΣΙΝΟΣ
14.414A ΛΕΥΚΗ ΒΑΣΗ
14.414B ΜΑΥΡΗ ΒΑΣΗ



ΦΑΝΟΣ ΠΛΕΥΡΙΚΟΣ LED
ΚΟΚΚΙΝΟΣ-ΠΡΑΣΙΝΟΣ
14.415A ΛΕΥΚΗ ΒΑΣΗ
14.415B ΜΑΥΡΗ ΒΑΣΗ



14.425A
ΦΑΝΟΣ LED ΠΛΑΙΝΟΣ
ΚΟΚ-ΠΡΑΣ ΑΣΗΜΙ



14.425B
ΦΑΝΟΣ LED ΠΛΑΙΝΟΣ
ΚΟΚ-ΠΡΑΣ ΜΑΥΡΟ



14.425C
ΦΑΝΟΣ LED ΠΛΑΙΝΟΣ
ΚΟΚ-ΠΡΑΣ ΛΕΥΚΟ



14.074
ΦΑΝΟΣ ΕΠΙΚΑΘΗΜΕΝΟΣ
ΚΟΚ-ΠΡΑΣ LED



14.065
ΦΑΝΟΣ ΠΛΑΙΝΟΣ ΠΡΑΣΙΝΟΣ
ΚΟΚΚΙΝΟΣ FLAT



14.003

ΦΑΝΟΣ ΠΛΕΥΡΙΚΟΣ
ΚΟΚΚΙΝΟΣ < 20m
Α ΛΕΥΚΟ / Β ΜΑΥΡΟ



14.004

ΦΑΝΟΣ ΠΛΕΥΡΙΚΟΣ
ΠΡΑΣΙΝΟΣ < 20m
Α ΛΕΥΚΟ / Β ΜΑΥΡΟ



14.225

ΦΑΝΟΣ ΔΙΠΛΟΣ
ΚΟΚΚΙΝΟΣ-ΠΡΑΣΙΝΟΣ < 20m
Α ΛΕΥΚΟ / Β ΜΑΥΡΟ



ΦΑΝΟΣ ΠΕΡΙΒΛΕΠΤΟΣ

14.224 ΛΕΥΚΟΣ < 20m

14.233 ΚΟΚΚΙΝΟΣ < 20m



14.001

ΦΑΝΟΣ ΕΦΙΣΤΙΟΣ < 20m
Α ΛΕΥΚΟ / Β ΜΑΥΡΟ



14.002

ΦΑΝΟΣ ΚΟΡΩΝΗΣ < 20m
Α ΛΕΥΚΟ / Β ΜΑΥΡΟ



14.046A

ΦΑΝΟΣ ΕΩΣ 20m
ΚΟΚΚΙΝΟ ΠΛΕΥΡΙΚΟΣ
LED



14.046B

ΦΑΝΟΣ ΕΩΣ 25m
ΚΟΚΚΙΝΟ ΠΛΕΥΡΙΚΟΣ
LED ΜΑΥΡΟΣ



14.047A

ΦΑΝΟΣ ΕΩΣ 20m
ΠΡΑΣΙΝΟΣ ΠΛΕΥΡΙΚΟΣ
LED



14.047B

ΦΑΝΟΣ ΕΩΣ 20m
ΠΡΑΣΙΝΟΣ
ΠΛΕΥΡΙΚΟΣ LED ΜΑΥΡΟΣ



ΦΑΝΟΣ ΔΙΠΛΟΣ LED
ΕΩΣ 20 m

14.050A ΛΕΥΚΟΣ
14.050B ΜΑΥΡΟΣ



14.048A ΦΑΝΟΣ
ΕΩΣ 20m ΚΟΡΩΝΗΣ LED

14.049A ΦΑΝΟΣ
ΕΩΣ 20m ΕΦΙΣΤΙΟΣ LED



14.048B ΦΑΝΟΣ ΕΩΣ 20m
ΚΟΡΩΝΗΣ LED ΜΑΥΡΟΣ

14.049B ΦΑΝΟΣ ΕΩΣ 20m
ΕΦΙΣΤΙΟΣ LED ΜΑΥΡΟΣ



14.052

ΦΑΝΟΣ ΑΓΚΥΡΟΒΟΛΙΑΣ
& ΝΑΥΣΙΠΛΟΪΑΣ



14.051

ΦΑΝΟΣ ΕΦΙΣΤΙΟΣ
ΚΑΙ ΦΩΣ
ΚΑΤΑΣΤΡΩΜΑΤΟΣ

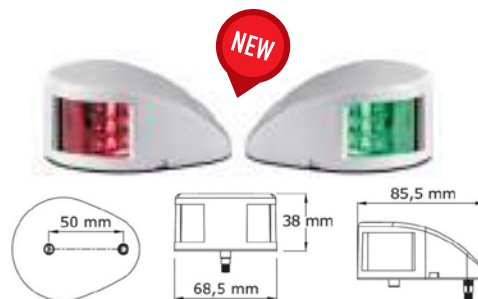

ΦΑΝΟΣ ΕΠΙΚΑΘΗΜΕΝΟΣ
MOUSE DECK ΕΩΣ 20m

14.063 ΚΟΚΚΙΝΟΣ

14.064 ΠΡΑΣΙΝΟΣ



99.059

99.059 ΦΑΝΟΣ ΟΒΑΛ
ΙΝΟΧ ΚΟΡΩΝΗΣ
CLASS ΕΩΣ 20m



99.058

99.058 ΦΑΝΟΣ ΙΝΟΧ ΟΒΑΛ
ΕΦΙΣΤΙΟΣ CLASS
ΕΩΣ 20m



ΦΑΝΟΣ ΟΒΑΛ ΙΝΟΧ CLASSIC
ΕΩΣ 20m

99.056 ΚΟΚΚΙΝΟΣ

99.057 ΠΡΑΣΙΝΟΣ



ΦΑΝΟΙ ΝΑΥΣΙΠΛΟΪΑΣ ΕΩΣ 50m //////////////////// ΗΛΕΚΤΡΟΛΟΓΙΚΟΣ ΕΞΟΠΛΙΣΜΟΣ



93.016

**ΦΑΝΟΣ ΠΕΡΙΒΛΕΠΤΟΣ
ΚΟΚΚΙΝΟΣ ΕΩΣ 50m**



93.017

**ΦΑΝΟΣ ΠΕΡΙΒΛΕΠΤΟΣ
ΠΡΑΣΙΝΟΣ ΕΩΣ 50m**



93.140

**ΦΑΝΟΣ ΠΛΕΥΡΙΚΟΣ
ΠΡΑΣΙΝΟΣ ΕΩΣ 50m**



93.021

ΦΑΝΟΣ ΕΦΙΣΤΙΟΣ ΕΩΣ 50m

93.022

ΦΑΝΟΣ ΚΟΡΩΝΗΣ ΕΩΣ 50m



93.018

ΦΑΝΟΣ ΠΕΡΙΒΛΕΠΤΟΣ ΛΕΥΚΟΣ ΕΩΣ 50m

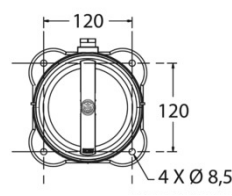
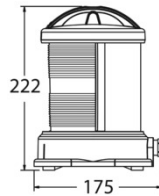
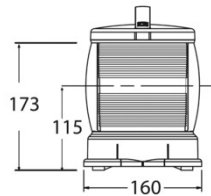

93.139

ΦΑΝΟΣ ΠΛΕΥΡΙΚΟΣ ΚΟΚΚΙΝΟΣ ΕΩΣ 50m

ΦΑΝΟΙ ΝΑΥΣΙΠΛΟΪΑΣ //////////////////// ΗΛΕΚΤΡΟΛΟΓΙΚΟΣ ΕΞΟΠΛΙΣΜΟΣ



14.081

**ΙΣΤΟΣ ΜΕΤΑΒΛΗΤΟΣ
ΛΕΥΚΟΣ 60cm**



14.085

**ΙΣΤΟΣ ΠΡΙΖΑΤΟΣ
ΛΕΥΚΟΣ 60 cm**



96.430

**ΙΣΤΟΣ ΠΡΙΖΑΤΟΣ
LED 60cm**



14.086

**ΙΣΤΟΣ LED 28cm
ΠΡΑΣ-ΚΟΚ**



ΙΣΤΟΣ ΜΕΤΑΒΛΗΤΟΣ

96.456 30cm LED

96.457 60cm LED



96.429

**ΙΣΤΟΣ ΜΕΤΑΒΛΗΤΟΣ
LED 60cm**



96.463

**ΙΣΤΟΣ ΜΕΤΑΒΛΗΤΟΣ
25cm TW**



ΙΣΤΟΣ LED ΠΕΡΙΒΛΕΠΤΟΣ ΛΕΥΚΟΣ

96.547 60cm

96.458 ΤΗΛΕΣΚΟΠΙΚΟΣ 60-120cm

96.459 ΤΗΛΕΣΚΟΠΙΚΟΣ 85-150cm

96.460 100cm



14.082

ΙΣΤΟΣ ΜΕΤΑΒΛΗΤΟΣ
ΛΕΥΚΟΣ 25cm



96.428

ΙΣΤΟΣ ΜΕΤΑΒΛΗΤΟΣ
25cm LED



96.462

ΙΣΤΟΣ ΜΕΤΑΒΛΗΤΟΣ
LED 8-30V 406x60mm



99.610 - ΙΣΤΟΣ ΑΚΥΒΕΡΝΗΣΙΑΣ 25cm

99.611 - ΙΣΤΟΣ ΑΚΥΒΕΡΝΗΣΙΑΣ 60cm



14.083

ΙΣΤΟΣ ΤΡΙΧΡΩΜΟΣ
25cm

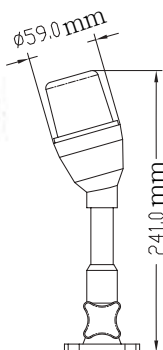

96.486

ΙΣΤΟΣ ΜΕΤΑΒΛΗΤΟΣ 25cm
ΜΕ LED ΜΑΥΡΟΣ



96.453

ΙΣΤΟΣ ΜΕΤΑΒΛΗΤΟΣ
ΜΑΥΡΟΣ 25cm LED



96.449

ΙΣΤΟΣ 3ΧΡΩΜΟΣ ΙΝΟΧ

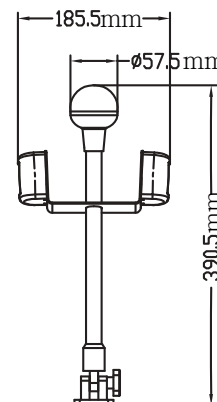

ΥΑΛΟΚΑΘΑΡΙΣΤΗΡΕΣ

ΗΛΕΚΤΡΟΛΟΓΙΚΟΣ ΕΞΟΠΛΙΣΜΟΣ



ΥΑΛΟΚΑΘΑΡΙΣΤΗΡΑΣ
ΜΗΧΑΝΙΣΜΟΣ ΙΝΟΧ

92.004

110°

92.014

90°



ΥΑΛΟΚΑΘΑΡΙΣΤΗΡΑΣ
ΜΟΤΕΡ Β.Τ. 83°-120°

92.016

ΚΟΝΤΗ ΒΙΔΑ

92.009

ΜΑΚΡΙΑ ΒΙΔΑ



92.015

ΥΑΛΟΚΑΘΑΡΙΣΤΗΡΑΣ 90°
ΜΕ ΛΑΣΤΙΧΟ 28 cm



ΜΠΡΑΤΣΟ ΥΑΛΟΚ/ΡΑ

92.010 155-255 mm

92.011 195-330 mm



ΛΑΣΤΙΧΟ ΥΑΛΟΚ/ΡΑ

92.012

28cm

92.013

35,5cm



ΛΑΣΤΙΧΟ ΥΑΛΟΚ/ΡΑ Β.Τ.

92.019

36cm

92.020

41cm



ΜΠΡΑΤΣΟ ΥΑΛΟΚ/ΡΑ Β.Τ.

92.017

27-36cm

92.018

33-42cm

NEW



15.253
ΠΥΞΙΔΑ ΔΙΟΠΤΕΥΣΗΣ
Α: ΜΠΛΕ / Β: ΚΟΚΚΙΝΗ
C: ΜΑΥΡΗ / D: ΓΚΡΙ

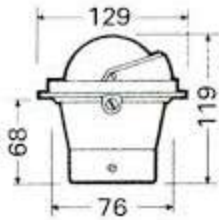

18.503
ΠΥΞΙΔΑ RIVIERA ΒΑ1 ΧΩΝΕΥΤΗ
Α: ΓΚΡΙ / Β: ΜΑΥΡΗ



ΠΥΞΙΔΑ SCOUT ΜΕ
ΒΑΣΗ 90x120mm
18.501 ΜΑΥΡΗ
18.500 ΛΕΥΚΗ



18.512
ΠΥΞΙΔΑ BC2
Α: ΛΕΥΚΗ / Β: ΜΑΥΡΗ

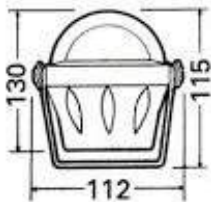

18.504
ΠΥΞΙΔΑ RIVIERA ΒΑ2 ΚΡΕΜΑΣΤΗ
Α: ΓΚΡΙ / Β: ΜΑΥΡΗ

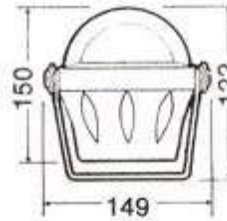

18.506
ΠΥΞΙΔΑ RIVIERA ΒΖ2 ΚΡΕΜΑΣΤΗ
Α: ΓΚΡΙ / Β: ΜΑΥΡΗ

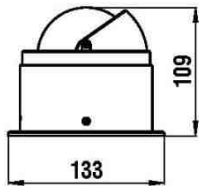

18.505
ΠΥΞΙΔΑ RIVIERA ΒΑ3 ΕΠΙΤΡΑΠΕΖΙΑ
Α: ΓΚΡΙ / Β: ΜΑΥΡΗ



18.508
ΠΥΞΙΔΑ RIVIERA ΒΖ3 ΕΠΙΤΡΑΠΕΖΙΑ
Α: ΓΚΡΙ / Β: ΜΑΥΡΗ



18.507
ΠΥΞΙΔΑ RIVIERA ΒΖ1 ΧΩΝΕΥΤΗ
Α: ΓΚΡΙ / Β: ΜΑΥΡΗ

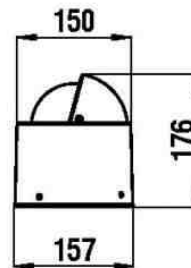

18.511
ΠΥΞΙΔΑ RIVIERA ΒU2 ΕΠΙΤΡΑΠΕΖΙΑ
Α: ΛΕΥΚΗ / Β: ΜΑΥΡΗ

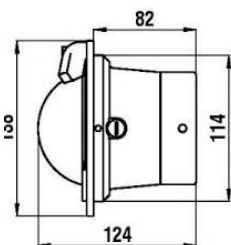

18.510
ΠΥΞΙΔΑ RIVIERA ΒΡ1 ΚΑΘΡΕΦΤΗ ΧΩΝΕΥΤΗ
Α: ΓΚΡΙ / Β: ΜΑΥΡΗ

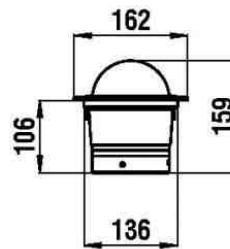

18.509
ΠΥΞΙΔΑ RIVIERA ΒU1 ΧΩΝΕΥΤΗ
Α: ΓΚΡΙ / Β: ΜΑΥΡΗ



99.745-A
TIMONI INOX ΓΚΡΙ 32cm
ΠΟΛΥΟΥΡΕΘΑΝΗΣ

99.741
TIMONI INOX ΓΚΡΙ 35cm
ΠΟΛΥΟΥΡΕΘΑΝΗΣ



99.745-B
TIMONI INOX ΜΑΥΡΟ 32cm
ΠΟΛΥΟΥΡΕΘΑΝΗΣ

99.742
TIMONI INOX ΜΑΥΡΟ 35cm
ΠΟΛΥΟΥΡΕΘΑΝΗΣ



99.737
TIMONI INOX ΜΠΕΖ
ΠΟΛΥΟΥΡΕΘΑΝΗΣ
Φ35cm



99.792
TIMONI 35mm
GOLF CARBON

NEW



99.748-A
TIMONI INOX LUXURY
35cm ΓΚΡΙ



99.748-B
TIMONI INOX LUXURY
35mm ΜΑΥΡΟ



99.746
TIMONI INOX / ΞΥΛΙΝΟ
TEAK 35cm



99.791
TIMONI 35mm
SIERRA CARBON

NEW



99.747-A
TIMONI INOX SPORT
35 cm ΓΚΡΙ



99.747-B
TIMONI INOX SPORT
35 cm ΜΑΥΡΟ



99.747-C
TIMONI INOX SPORT
35 cm ΜΠΕΖ



99.793
TIMONI 35mm
QUEBEK CARBON

NEW



99.740
TIMONI SS316 INOX 35mm

99.760
TIMONI SS316 INOX 40mm



99.743
TIMONI INOX ΜΕ ΟΔΗΓΟ Φ33cm

99.744
TIMONI INOX ΜΕ ΟΔΗΓΟ Φ39cm



99.794A
TIMONI 35mm ΛΕΥΚΟ
VICTOR



99.794B
TIMONI 35mm ΜΑΥΡΟ
VICTOR



99.796
TIMONI ΞΥΛΙΝΟ 35mm
ΜΕ ΟΔΗΓΟ

NEW



99.732A
TIMONI INOX LIMA 35mm ΓΚΡΙ



99.732B
TIMONI INOX LIMA 35mm ΜΑΥΡΟ

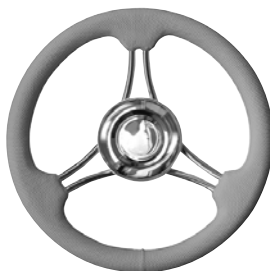

99.761A
TIMONI INOX 35mm RG ΓΚΡΙ



99.732C
TIMONI INOX LIMA 35mm ΜΠΕΖ



99.761C
TIMONI INOX 35mm RG ΜΠΕΖ



99.761B
TIMONI INOX 35mm RG ΜΑΥΡΟ



99.761D
TIMONI INOX 35mm RG



99.733A
TIMONI COMPACT INOX ΓΚΡΙ



99.733B
TIMONI COMPACT INOX ΜΑΥΡΟ



99.738
TIMONI 350MM MV ΜΑΥΡΟ

NEW



99.797
TIMONI ΞΥΛΙΝΟ Ø35

NEW



99.801
TIMONI T25 GHOST BLACK

NEW



99.802
TIMONI T256GHOST BLACK

NEW



99.803
TIMONI T28 GHOST BLACK

NEW



99.811
TIMONI ΠΛΑΣΤΙΚΟ SM ΕΝΙΣΧΥΜΕΝΟ

NEW



99.812
TIMONI SM ΜΕ ΟΔΗΓΟ



ΤΙΜΟΝΙΑ ΞΥΛΙΝΑ

ΚΩΔ.	ΠΕΡΙΓΡΑΦΗ
24.601	ΤΙΜΟΝΙ ΞΥΛΙΝΟ 12" - 30cm
24.602	ΤΙΜΟΝΙ ΞΥΛΙΝΟ 16" - 40cm
24.603	ΤΙΜΟΝΙ ΞΥΛΙΝΟ 20" - 50cm
24.604	ΤΙΜΟΝΙ ΞΥΛΙΝΟ 24" - 60cm
24.605	ΤΙΜΟΝΙ ΞΥΛΙΝΟ 28" - 70cm
24.606	ΤΙΜΟΝΙ ΞΥΛΙΝΟ 32" - 80cm
24.607	ΤΙΜΟΝΙ ΞΥΛΙΝΟ 36" - 90cm
24.608	ΤΙΜΟΝΙ ΞΥΛΙΝΟ 40" - 100cm



98.181A
ΟΔΗΓΟΣ ΤΙΜΟΝΙΟΥ ΓΚΡΙ



98.181B
ΟΔΗΓΟΣ ΤΙΜΟΝΙΟΥ ΜΑΥΡΟΣ



98.181C
ΟΔΗΓΟΣ ΤΙΜΟΝΙΟΥ ΞΥΛΙΝΟΣ



17.501
ΠΡΟΕΚΤΑΣΗ ΓΚΑΖΙΟΥ ΠΤΥΣΟΜΕΝΗ
17.502
ΠΡΟΕΚΤΑΣΗ ΓΚΑΖΙΟΥ ΣΤΑΘΕΡΗ



98.169
ΟΔΗΓΟΣ ΤΙΜΟΝΙΟΥ ΙΝΟΧ
"ΤΕΜΠΕΛΗΣ"

ΠΛΟΗΓΗΣΗ

ΑΞΕΣΟΥΑΡ ΠΛΟΗΓΗΣΗΣ



16.113 - ΧΕΙΡΙΣΤΗΡΙΟ ΜΟΝΟ ΓΙΑ 1 ΜΗΧΑΝΗ*
16.114 - ΧΕΙΡΙΣΤΗΡΙΟ ΔΙΠΛΟ ΓΙΑ 2 ΜΗΧΑΝΕΣ*
* ΓΚΑΖΙ ΚΑΙ ΡΕΒΕΡΣΑ



16.111
ΧΕΙΡΙΣΤΗΡΙΟ ΜΟΝΟ*
* ΡΕΒΕΡΣΑ



16.112
ΧΕΙΡΙΣΤΗΡΙΟ ΔΙΠΛΟ
ΓΙΑ ΜΙΑ ΜΗΧΑΝΗ*
* ΓΚΑΖΙ ΚΑΙ ΡΕΒΕΡΣΑ



93.030
ΚΛΕΙΔΙ ΑΣΦΑΛΕΙΑΣ
QUICK STOP
ΓΙΑ ΟΛΟΥΣ ΤΟΥΣ
ΤΥΠΟΥΣ
ΚΙΝΗΤΗΡΑ

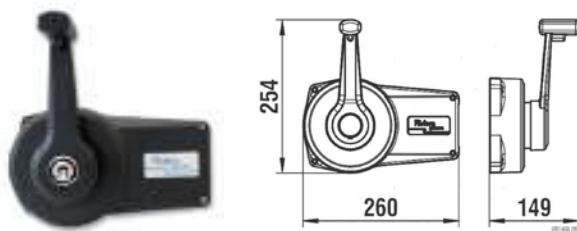

81.309
ΧΕΙΡΙΣΤΗΡΙΟ ΠΛΑΙΝΟ ΜΗΧΑΝΗΣ



81.310
ΧΕΙΡΙΣΤΗΡΙΟ ΠΛΑΙΝΟ ΜΗΧΑΝΗΣ



- 13.015 - ΦΛΑΠΣ ΙΝΟΧ W20 x D25 cm
 13.029 - ΦΛΑΠΣ ΙΝΟΧ W25 x D25 cm
 13.016 - ΦΛΑΠΣ ΙΝΟΧ W28.5 x D25 cm
 13.017 - ΦΛΑΠΣ ΙΝΟΧ W37 x D25 cm



LENCO HIGH PERFORMANCE

ΚΩΔΙΚΟΣ	V	ΜΗΚΟΣ mm	ΒΑΘΟΣ mm	ΣΚΑΦΟΣ m
13.045	12	305	457	8 -12m



ΥΔΡΟΠΤΕΡΥΓΙΟ ΜΗΧΑΝΗΣ

- 27.001 - ΕΩΣ 50HP
 27.004 - ΕΩΣ 200HP

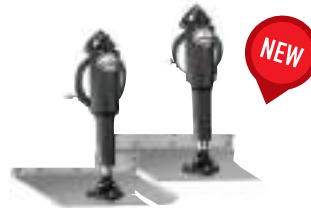

LENCO HIGH PERFORMANCE

ΚΩΔΙΚΟΣ	V	ΜΗΚΟΣ mm	ΒΑΘΟΣ mm	ΣΚΑΦΟΣ m
13.041	12	229	305	5 - 7,5
13.042	12	229	457	6,6 - 9
13.043	12	305	457	8 - 10,8



- 13.030 - ΗΛΕΚΤΡΙΚΟ ΣΕΤ ΦΛΑΠΣ ΜΕ ΠΛΑΚΕΣ ΙΝΟΧ 30x23 cm
 13.032 - ΗΛΕΚΤΡΙΚΟ ΣΕΤ ΦΛΑΠΣ ΜΕ ΠΛΑΚΕΣ ΙΝΟΧ 40x23 cm
 13.031 - ΒΡΑΧΙΟΝΑΣ ΗΛΕΚΤΡΙΚΟΣ (ΖΕΥΓΟΣ)



13.035 - ΦΛΑΠΣ ΗΛΕΚΤΡΙΚΟ Lenco



13.036
 ΧΕΙΡΙΣΤΗΡΙΟ Lenco



13.037
 ΧΕΙΡΙΣΤΗΡΙΟ Lenco
 ΜΕ ΕΝΔΕΙΞΗ



81.200 - ΥΔΡΑΥΛΙΚΟ ΣΥΣΤΗΜΑ ΤΙΜΟΝΙΟΥ ΕΩΣ 100HP
• ΣΤΡΟΦΕΣ 5,2
• 2 ΣΩΛΗΝΕΣ 1/4" / 5 ΜΕΤΡΑ



81.201 - ΥΔΡΑΥΛ. ΣΥΣΤΗΜΑ ΤΙΜΟΝΙΟΥ ΕΩΣ 150HP
• ΣΤΡΟΦΕΣ 4,9
• 2 ΣΩΛΗΝΕΣ 1/4" / 6 ΜΕΤΡΑ



81.202 - ΥΔΡΑΥΛ. ΣΥΣΤΗΜΑ ΤΙΜΟΝΙΟΥ ΕΩΣ 300HP
• ΣΤΡΟΦΕΣ 5,2
• 2 ΣΩΛΗΝΕΣ 5/16" / 7,5 ΜΕΤΡΑ



81.203 - ΥΔΡΑΥΛ. ΣΥΣΤΗΜΑ ΤΙΜΟΝΙΟΥ ΕΩΣ 350 HP
• ΣΤΡΟΦΕΣ 5,2
• 2 ΣΩΛΗΝΕΣ 5/16" / 7,5 ΜΕΤΡΑ



ΥΔΡΑΥΛ. ΣΥΣΤΗΜΑ ΤΙΜΟΝΙΟΥ ΕΣΩΛΕΜΒΙΑΣ

81.205 - ΑΠΟ 20 ΕΩΣ 40 FT ΣΚΑΦΟΣ

81.206 - ΑΠΟ 24 ΕΩΣ 44 FT ΣΚΑΦΟΣ



82.401 ΥΔΡΑΥΛΙΚΟ ΣΥΣΤΗΜΑ ΤΙΜΟΝΙΟΥ SM ΕΩΣ 90HP

ΠΕΡΙΛΑΜΒΑΝΕΙ:

- ΑΝΤΛΙΑ 14cc
- ΚΥΛΙΝΔΡΟΣ ΕΩΣ 90 hp
- 5/16 ΥΔΡΑΥΛΙΚΕΣ ΣΩΛΗΝΕΣ 2 Pcs x 8 mt (26FT)
- ΑΞΕΣΟΥΑΡ ΤΟΠΟΘΕΤΗΣΗΣ



82.402 ΥΔΡΑΥΛΙΚΟ ΣΥΣΤΗΜΑ ΤΙΜΟΝΙΟΥ SM ΕΩΣ 200HP

ΠΕΡΙΛΑΜΒΑΝΕΙ:

- ΑΝΤΛΙΑ 20cc
- ΚΥΛΙΝΔΡΟΣ ΕΩΣ 200 hp
- 5/16 ΥΔΡΑΥΛΙΚΕΣ ΣΩΛΗΝΕΣ 2 Pcs x 8 mt (26FT)
- ΑΞΕΣΟΥΑΡ ΤΟΠΟΘΕΤΗΣΗΣ



82.403 ΥΔΡΑΥΛΙΚΟ ΣΥΣΤΗΜΑ ΤΙΜΟΝΙΟΥ SM ΕΩΣ 300HP

ΠΕΡΙΛΑΜΒΑΝΕΙ:

- ΑΝΤΛΙΑ 24cc
- ΚΥΛΙΝΔΡΟΣ ΕΩΣ 3000 hp
- 5/16 ΥΔΡΑΥΛΙΚΕΣ ΣΩΛΗΝΕΣ 2 Pcs x 8 mt (26FT)
- ΑΞΕΣΟΥΑΡ ΤΟΠΟΘΕΤΗΣΗΣ



82.421 ΚΥΛΙΝΔΡΟΣ 90HP



82.422 ΚΥΛΙΝΔΡΟΣ 200HP



82.423 ΚΥΛΙΝΔΡΟΣ 300HP



ΜΠΟΥΚΑΛΑ-ΑΝΤΛΙΑ

82.411 90HP

82.412 200HP

82.413 300HP



81.253 - ΚΥΛΙΝΔΡΟΣ ΕΩΣ 100HP



81.254 - ΚΥΛΙΝΔΡΟΣ ΕΩΣ 150HP



81.255 - ΚΥΛΙΝΔΡΟΣ ΕΩΣ 300HP



81.256 - ΚΥΛΙΝΔΡΟΣ ΕΩΣ 350HP



ΜΠΟΥΚΑΛΑ ΥΔΡ/ΚΟΥ ΤΙΜΟΝΙΟΥ

81.250	16cc
81.251	17cc
81.252	27cc



81.259

ΤΑΠΑ ΠΛΗΡΩΣΗΣ ΛΑΔΙΟΥ ΥΔΡΑΥΛΙΚΗΣ ΜΠΟΥΚΑΛΑΣ



81.501 - ΣΕΤ ΣΩΛΗΝΑ ΥΔΡΑΥΛ. ΤΙΜΟΝΙΟΥ 1/4" 24ft

81.502 - ΣΕΤ ΣΩΛΗΝΑ ΥΔΡΑΥΛ. ΤΙΜΟΝΙΟΥ 5/16" 24ft



ΑΝΤΑΛΛΑΚΤΙΚΟ ΚΙΤ ΓΙΑ ΚΥΛΙΝΔΡΟ

81.265 90HP ΚΑΙ 150HP MV

81.266 300HP MV



ΚΑΠΑΚΙ ΚΥΛΙΝΔΡΟΥ

81.263A 90HP

81.263B 150HP

81.263C 300HP

81.263D 350HP



ΤΣΙΜΟΥΧΕΣ-ΜΠΟΥΚΑΛΑ

81.267A 90HP

81.267B 150HP

81.267C 300-350HP



81.314

ΚΙΤ SUZUKI ΕΩΣ 200HP



ΥΔΡΑΥΛ. ΚΙΤ ΜΠΟΥΚΑΛΑΣ

81.702 17cc 150HP MV

81.703 27cc MV 300HP



81.316

ΚΙΤ UNIVERSAL

200-300HP



ΡΑΚΟΡ ΖΕΥΓΟΣ ΥΔΡΑΥΛΙΚΟΥ ΤΙΜΟΝΙΟΥ

81.257 1/4"

81.258 5/16"



81.260

ΡΑΚΟΡ ΓΩΝΙΑΚΟ ΓΙΑ ΥΔΡΑΥΛΙΚΟ ΣΥΣΤΗΜΑ



81.315

ΚΙΤ YAMAHA HONDA

40-200 HP



ΣΕΤ ΤΣΙΜΟΥΧΕΣ ΥΔΡΑΥΛΙΚΟΥ ΚΥΛΙΝΔΡΟΥ

81.261A 90HP

81.261B 150HP

81.261C 300HP

81.261D 350HP



81.319

ΛΑΔΙ ΥΔΡΑΥΛΙΚΟΥ ΤΙΜΟΝΙΟΥ 1LT MV



81.318

ΛΑΔΙ ΥΔΡΑΥΛΙΚΟΥ ΤΙΜΟΝΙΟΥ 1lt OSC



81.317

ΚΙΤ MERCURY OPTIMAX



10.807
ΤΑΠΑ ΣΥΡΜΑΤΟΣΧΟΙΝΟΥ



25.031
ΝΤΙΖΟΦΟΥΣΚΑ ΜΕ ΒΑΣΗ 105mm
Α: ΛΕΥΚΟ / Β: ΜΑΥΡΟ / C: ΓΚΡΙ



25.032
ΝΤΙΖΟΦΟΥΣΚΑ ΜΕ ΒΑΣΗ Φ 152mm
Α: ΛΕΥΚΟ / Β: ΜΑΥΡΟ / C: ΓΚΡΙ



25.033
ΝΤΙΖΟΦΟΥΣΚΑ Φ 50mm
Α: ΛΕΥΚΟ / Β: ΜΑΥΡΟ / C: ΓΚΡΙ



25.034
ΝΤΙΖΟΦΟΥΣΚΑ Φ 69mm
Α: ΛΕΥΚΟ / Β: ΜΑΥΡΟ / C: ΓΚΡΙ



25.035
ΝΤΙΖΟΦΟΥΣΚΑ Φ 94mm
Α: ΛΕΥΚΟ / Β: ΜΑΥΡΟ



25.041
ΝΤΙΖΟΦΟΥΣΚΑ ΜΕ ΔΥΟ ΑΚΡΑ Φ105mm
Α: ΛΕΥΚΟ / Β: ΜΑΥΡΟ / C: ΓΚΡΙ



ΒΑΣΗ ΠΛΑΣΤΙΚΗ ΓΙΑ ΣΩΛΗΝΑ ΝΤΙΖΩΝ

25.061A - ΛΕΥΚΗ

25.061B - ΜΑΥΡΗ



ΤΕΡΜΑΤΙΚΟ ΣΩΛΗΝΑΣ
ΝΤΙΖΩΝ

25.062A ΛΕΥΚΟ

25.062B ΜΑΥΡΟ

25.062C ΓΚΡΙ



25.060

ΣΩΛΗΝΑΣ ΓΙΑ ΝΤΙΖΕΣ-ΚΑΛΩΔΙΑ Φ51mm 10 ΜΕΤΡΑ

Α: ΛΕΥΚΟ Β: ΜΑΥΡΟ C: ΓΚΡΙ



ΠΡΟΣΤΑΤΕΥΤΙΚΟ ΠΡΟΠΕΛΑΣ

ΚΩΔΙΚΟΣ	HP	ΧΡΩΜΑ
99.351	9-15	ΚΙΤΡΙΝΟ
99.352	20-30	ΠΟΡΤΟΚΑΛΙ
99.353	40-60	ΜΠΛΕ
99.354	70-140	ΚΟΚΚΙΝΟ
99.355	135-250	ΛΕΥΚΟ



16.115
ΕΠΙΛΟΓΕΑΣ ΝΤΙΖΩΝ



82.201
ΑΝΤΑΛΛΑΚΤΙΚΟ ΝΤΙΖΩΝ LM-K-1



82.203
ΑΝΤΑΛΛΑΚΤΙΚΟ ΝΤΙΖΩΝ LM-K-3



82.204
ΑΝΤΑΛΛΑΚΤΙΚΟ ΝΤΙΖΩΝ ET LM-K-4



82.205
ΑΝΤΑΛΛΑΚΤΙΚΟ ΝΤΙΖΩΝ ET LM-K-5



82.206
ΑΝΤΑΛΛΑΚΤΙΚΟ ΝΤΙΖΩΝ BT LM-K-6



82.207
ΑΝΤΑΛΛΑΚΤΙΚΟ ΝΤΙΖΩΝ LM-K-7



82.208
ΑΝΤΑΛΛΑΚΤΙΚΟ ΝΤΙΖΩΝ LM-K-8



82.209
ΑΝΤΑΛΛΑΚΤΙΚΟ ΝΤΙΖΩΝ LM-K-9



82.210
ΑΝΤΑΛΛΑΚΤΙΚΟ ΝΤΙΖΩΝ LM-K-10



82.211
ΑΝΤΑΛΛΑΚΤΙΚΟ ΝΤΙΖΩΝ LM-K-11



82.212
ΑΝΤΑΛΛΑΚΤΙΚΟ ΝΤΙΖΩΝ LM-K-12.jpg



82.214
ΑΝΤΑΛΛΑΚΤΙΚΟ ΝΤΙΖΩΝ LM-K-14



81.701
ΜΗΧΑΝΙΣΜΟΣ ΤΙΜΟΝΙΟΥ BT MAVI MARE



81.4xx*
ΝΤΙΖΑ ΧΕΙΡΙΣΤΗΡΙΟΥ C5
MAVI MARE



81.0xx*
ΝΤΙΖΑ ΧΕΙΡΙΣΤΗΡΙΟΥ C8
MAVI MARE



81.6xx*
ΝΤΙΖΑ ΤΙΜΟΝΙΟΥ BT
MAVI MARE



82.6xx
ΝΤΙΖΑ ΧΕΙΡΙΣΤΗΡΙΟΥ C14 OMC
TEFLON



82.5xx
ΝΤΙΖΑ ΧΕΙΡΙΣΤΗΡΙΟΥ C5
MERCURY, MARINER, TEFLON



81.9xx
ΝΤΙΖΑ ΧΕΙΡΙΣΤΗΡΙΟΥ C8 YAMAHA
SUZUKI, HONDA, TOHATSU, TEFLON



81.8xx
ΝΤΙΖΑ ΤΙΜΟΝΙΟΥ BT



81.801
81.801 ΜΗΧΑΝΙΣΜΟΣ
ΤΙΜΟΝΙΟΥ BT (ΚΛΩΒΟΣ)



81.802
ΑΞΕΣΟΥΑΡ ΜΗΧΑΝΙΣΜΟΥ BT

* xx=ΜΗΚΟΣ σε ft



82.1xx*
 ΝΤΙΖΑ ΧΕΙΡΙΣΤΗΡΙΟΥ
 TEFLON C5
 MERCURY - MARINER



81.5xx
 ΝΤΙΖΑ ΧΕΙΡΙΣΤΗΡΙΟΥ TEFLON OMC
 ΓΙΑ ΜΗΧΑΝΕΣ ΜΕΤΑ 1979



82.0xx*
 ΝΤΙΖΑ ΧΕΙΡΙΣΤΗΡΙΟΥ TEFLON C8
 YAMAHA-HONDA-SUZUKI-
 NISSAN-TOHATSU-SELVA



81.1xx*
 ΝΤΙΖΑ ΤΙΜΟΝΙΟΥ
 ΕΛΑΦΡΙΟΥ ΤΥΠΟΥ



81.2xx*
 ΝΤΙΖΑ ΤΙΜΟΝΙΟΥ
 ΒΑΡΕΩΣ ΤΥΠΟΥ

* xx=ΜΗΚΟΣσε ft



81.302 - ΜΗΧΑΝΙΣΜΟΣ ΤΙΜΟΝΙΟΥ
 Β.Τ. ΕΩΣ 200HP



81.304
 ΑΞΕΣΟΥΑΡ ΜΗΧΑΝΙΣΜΟΥ ΤΙΜΟΝΙΟΥ Β.Τ.

81.303 - ΜΗΧΑΝΙΣΜΟΣ ΤΙΜΟΝΙΟΥ
 Β.Τ. ΕΩΣ 200HP ΧΩΡΙΣ ΕΠΑΝΑΦΟΡΑ



81.301
 ΜΗΧΑΝΙΣΜΟΣ ΤΙΜΟΝΙΟΥ
 Ε.Τ. ΕΩΣ 55HP



86.011
ΒΑΣΗ ΑΜΟΡΤΙΣΕΡ "L" ΜΠΙΛΙΑ ΕΣΩ



86.012
ΒΑΣΗ ΑΜΟΡΤΙΣΕΡ "L" ΜΠΙΛΙΑ ΕΞΩ



86.013
ΒΑΣΗ ΑΜΟΡΤΙΣΕΡ "L" ΒΙΔΑ ΕΣΩ



86.014
ΒΑΣΗ ΑΜΟΡΤΙΣΕΡ "L" ΒΙΔΑ ΕΞΩ



86.015
ΒΑΣΗ ΑΜΟΡΤΙΣΕΡ ΒΙΔΑ ΚΑΘΕΤΗ



86.016
ΒΑΣΗ ΑΜΟΡΤΙΣΕΡ ΜΠΙΛΙΑ ΚΑΘΕΤΗ



ΑΜΟΡΤΙΣΕΡ ΕΛΑΤΗΡΙΟ

- 86.201** 22cm
- 86.202** 26cm



ΑΜΟΡΤΙΣΕΡ ΜΠΙΛΙΑ-ΤΡΥΠΑ

ΚΩΔ.	ΑΝΟΙΧΤΟ mm	ΒΑΡΟΣ kg
86.151	350	18
86.152	550	20
86.153	550	38
86.154	600	36



ΑΜΟΡΤΙΣΕΡ ΙΝΟΧ ΜΠΙΛΙΑ-ΜΠΙΛΙΑ

ΚΩΔ.	ΑΝΟΙΧΤΟ mm	ΒΑΡΟΣ kg
86.101	254	9
86.102	305	20
86.103	380	18
86.104	500	20
86.105	700	30



ΑΜΟΡΤΙΣΕΡ ΤΡΥΠΑ-ΤΡΥΠΑ

ΚΩΔ.	ΑΝΟΙΧΤΟ mm	ΒΑΡΟΣ kg
86.251	244	5
86.252	355	25
86.253	550	15
86.254	600	20



ΑΜΟΡΤΙΣΕΡ ΙΝΟΧ ΤΡΥΠΑ-ΤΡΥΠΑ

ΚΩΔ.	ΑΝΟΙΧΤΟ mm	ΒΑΡΟΣ kg
86.001	250	10
86.002	350	20
86.003	500	20
86.004	700	25
86.005	700	45



19.011
ΕΣΤΙΑ ΓΚΑΖΙΟΥ ΧΩΝΕΥΤΗ
ΜΙΑ ΕΣΤΙΑ L32xW28.5cm



19.085
ΕΣΤΙΑ ΧΩΝΕΥΤΗ ΔΥΟ ΕΣΤΙΕΣ



19.013
ΕΣΤΙΑ ΧΩΝΕΥΤΗ
3 ΕΣΤΙΕΣ L47xW36cm



19.083
ΕΣΤΙΑ ΧΩΝΕΥΤΗ ΓΥΑΛΙΝΗ
ΜΟΝΗ L36xW20cm



19.012
ΕΣΤΙΑ ΓΚΑΖΙΟΥ ΧΩΝΕΥΤΗ
2 ΕΣΤΙΕΣ L38xW36cm



19.090
ΕΣΤΙΑ ΓΚΑΖΙΟΥ ΧΩΝΕΥΤΗ
ΜΕ ΚΑΠΑΚΙ ΜΙΑ ΕΣΤΙΑ Φ34cm



19.101
ΕΣΤΙΑ ΧΩΝΕΥΤΗ ΟΒΑΛ
ΔΙΠΛΗ ΜΕ ΚΑΠΑΚΙ L53xW34cm



19.100
ΕΣΤΙΑ ΓΚΑΖΙΟΥ ΜΕ ΚΑΠΑΚΙ
2 ΕΣΤΙΕΣ L53xW33cm

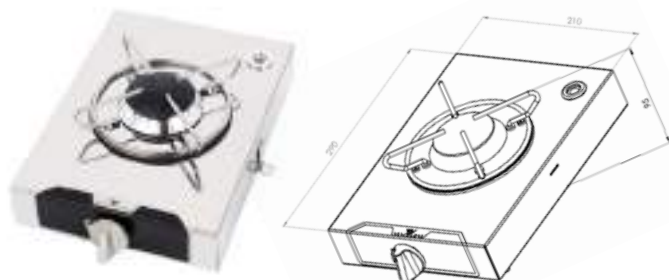

19.023
ΕΣΤΙΑ ΓΚΑΖΙΟΥ ΕΠΙΤΡΑΠΕΖΙΑ
ΜΙΑ ΕΣΤΙΑ L21xW29cm



19.021
ΕΣΤΙΑ ΕΠΙΤΡΑΠΕΖΙΑ
ΜΙΑ ΕΣΤΙΑ L28,5xW28.5cm

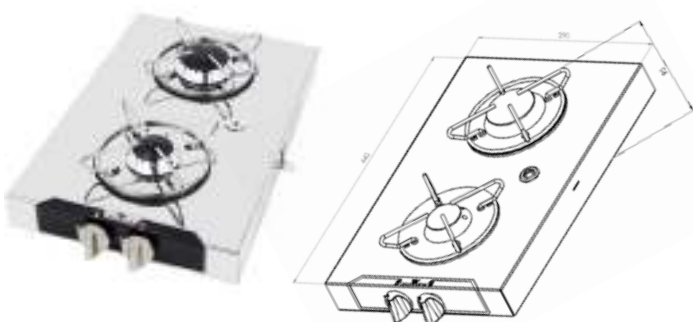

19.092
ΕΣΤΙΑ ΓΚΑΖΙΟΥ ΕΠΙΤΡΑΠΕΖΙΑ
2 ΕΣΤΙΕΣ L36xW33cm



19.022
ΕΣΤΙΑ ΓΚΑΖΙΟΥ ΕΠΙΤΡΑΠΕΖΙΑ
2 ΕΣΤΙΕΣ L44xW29cm



19.104
ΕΣΤΙΑ ΓΚΑΖΙΟΥ ΕΠΙΤΡΑΠΕΖΙΑ
3 ΕΣΤΙΕΣ L48xW37cm

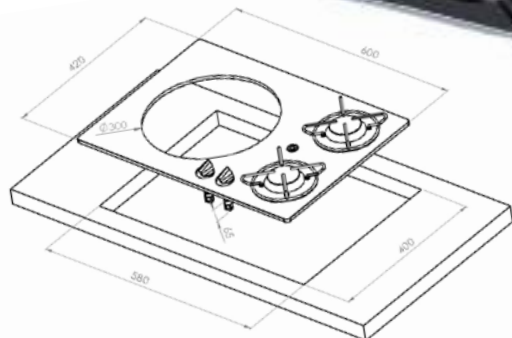

19.087
ΕΣΤΙΑ ΓΥΑΛΙΝΗ
ΔΥΟ ΕΣΤΙΕΣ +ΝΕΡΟΧΥΤΗΣ
L80xW42cm



19.081 - ΕΣΤΙΑ +ΝΕΡΟΧΥΤΗΣ
ΤΕΤΡΑΓΩΝΟΣ L35xW32cm

ΑΞΕΣΟΥΑΡ ΕΣΤΙΑΣ-ΚΟΥΖΙΝΑΣ ////////// ΜΟΝΙΜΟΣ ΕΞΟΠΛΙΣΜΟΣ ΣΚΑΦΟΥΣ



19.031
ΒΑΣΕΙΣ ΣΤΕΡΕΩΣΗΣ
ΕΣΤΙΩΝ ΓΚΑΖΙΟΥ



19.041
ΒΑΣΕΙΣ ΣΤΕΡΕΩΣΗΣ ΣΚΕΥΩΝ
ΓΙΑ ΚΟΥΖΙΝΑ



19.032
ΒΑΣΗ ΣΤΕΡΕΩΣΗΣ ΣΚΕΥΩΝ ΔΙΠΛΗ



19.033
ΒΑΣΗ ΣΤΕΡΕΩΣΗΣ ΣΚΕΥΩΝ
ΓΙΑ ΤΡΙΑ ΣΚΕΥΗ



19.031
ΒΑΣΗ ΣΤΕΡΕΩΣΗΣ ΣΚΕΥΩΝ ΜΟΝΗ

ΘΕΡΜΟΣΙΦΩΝΕΣ ////////// ΜΟΝΙΜΟΣ ΕΞΟΠΛΙΣΜΟΣ ΣΚΑΦΟΥΣ



94.301



94.300



94.302-3-4-5

ΘΕΡΜΟΣΙΦΩΝΕΣ ΗΛΕΚΤΡΙΚΟΙ ΙΝΟΧ

ΚΩΔΙΚΟΣ	ΛΙΤΡΑ	ΣΧΗΜΑ	ΠΛΑΤΟΣ mm	ΜΗΚΟΣ mm
94.300	12	ΚΥΛΙΝΔΡΙΚΟ	255	388
94.301	20	ΠΑΡΑΛ/ΜΟ	190	550
94.302	22	ΚΥΛΙΝΔΡΙΚΟ	320	490
94.303	30	ΚΥΛΙΝΔΡΙΚΟ	320	620
94.304	45	ΚΥΛΙΝΔΡΙΚΟ	320	880
94.305	60	ΚΥΛΙΝΔΡΙΚΟ	320	1.070



94.316
ΘΕΡΜΟΣΤΑΤΗΣ ΑΤΙ 230 Ω 1250W



94.315
ΑΝΤΙΣΤΑΣΗ ΘΕΡΜΟΣΙΦΩΝΑ 230Ω 1250W



19.001
ΚΟΥΖΙΝΑ INOX 3 ΕΣΤΙΕΣ
W50 x H39 x D41



19.002
ΚΟΥΖΙΝΑ INOX 2 ΕΣΤΙΕΣ
W50xH39xD41



19.102
ΜΑΓΜΑ-ΜΠΑΡΜΠΕΚΙΟΥ ΓΚΑΖΙΟΥ INOX ΓΙΑ ΡΕΛΙΑ



19.105
ΚΑΛΥΜΑ ΜΠΑΡΜΠΕΚΙΟΥ



19.005
ΠΡΟΣΤΑΤΕΥΤΙΚΟ ΚΟΥΖΙΝΑΣ INOX



19.103
ΚΙΤ ΓΙΑ ΜΠΑΡΜΠΕΚΙΟΥ
CAMPINGAZ
ΜΕ ΑΝΑΜΟΝΗ ΓΙΑ 1 ΦΙΑΛΗ

ΑΝΤΑΛΛΑΚΤΙΚΑ ΚΟΥΖΙΝΑΣ

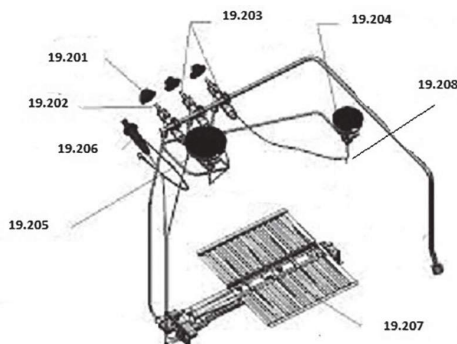

- 19.201** ΚΟΥΜΠΙ
- 19.202** ΒΑΛΒΙΔΑ ΑΕΡΙΟΥ ΦΟΥΡΝΟΥ
- 19.203** ΒΑΛΒΙΔΑ ΑΕΡΙΟΥ ΜΑΤΙΟΥ
- 19.204** ΜΑΤΙ ΜΙΚΡΟ
- 19.205** ΜΑΤΙ ΜΕΓΑΛΟ
- 19.206** ΑΝΑΦΛΕΚΤΗΡΑΣ
- 19.207** ΚΑΥΣΤΗΡΑΣ ΦΟΥΡΝΟΥ
- 19.208** THERMO-COUPLE



19.051
INOX L32xW17xH15cm



19.052
ΝΕΡΟΧΥΤΗΣ INOX L32xW26xH15cm



19.053
ΝΕΡΟΧΥΤΗΣ INOX L35xW26xH15cm



19.054
ΝΕΡΟΧΥΤΗΣ INOX L35xW32xH15cm



19.055
ΝΕΡΟΧΥΤΗΣ INOX L36xW36xH15cm



ΝΕΡΟΧΥΤΗΣ INOX
19.061 Ø26cm
19.064 Ø30cm
19.065 Ø36cm



19.091
ΝΕΡΟΧΥΤΗΣ ΜΕ ΒΡΥΣΗ ΚΑΠΑΚΙ
L35xW32cm



93.001
ΜΠΑΤΑΡΙΑ ΝΕΡΟΧΥΤΗ
INOX ΜΟΝΗ

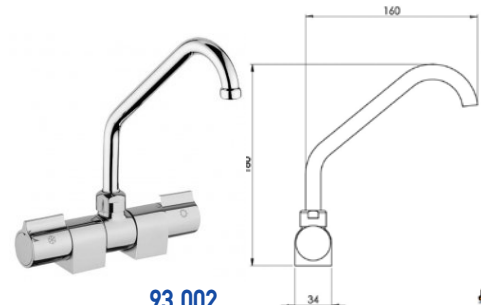

93.002
ΜΠΑΤΑΡΙΑ ΝΕΡΟΧΥΤΗ
INOX ΔΙΠΛΗ



93.003
ΜΠΑΤΑΡΙΑ ΝΕΡΟΧΥΤΗ
ΜΑΥΡΗ



93.004
ΜΠΑΤΑΡΙΑ ΝΕΡΟΧΥΤΗ
FLAT INOX



93.005
ΜΠΑΤΑΡΙΑ ΝΕΡΟΧΥΤΗ FLAT ΜΑΥΡΗ

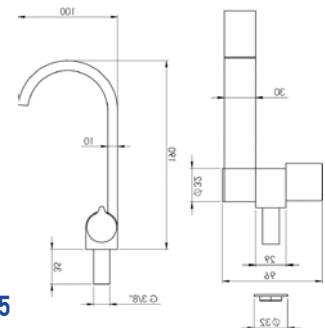

93.006
ΜΠΑΤΑΡΙΑ ΝΕΡΟΧΥΤΗ ΜΕ
ΠΤΥΣΣΟΜΕΝΟ ΝΤΟΥΣ



19.063
ΡΑΚΟΡ ΝΕΡΟΧΥΤΗ
ΓΩΝΙΑΚΟ



19.071
ΡΑΚΟΡ ΝΕΡΟΧΥΤΗ
ΙΣΙΟ



90.061



90.062



90.063
90.064



90.065



90.066



90.067

ΨΥΓΕΙΑ IGLOO ULTRA

ΚΩΔΙΚΟΣ	ΧΩΡΗΤ/ΤΑ Lt	MODEL	ΔΙΑΣΤΑΣΕΙΣ cm	ΤΑΠΑ
90.061	23	ULTRA 25	M59 x Π27 x Y33	-
90.062	28	ULTRA 30	M43 x Π34 x Y42	-
90.063	34	ULTRA 36	M60 x Π35 x Y34	-
90.064	47	PROFILE	M65 x Π37 x Y37	ΝΑΙ
90.065	51	ULTRA 54	M65 x Π39 x Y39	ΝΑΙ
90.066	65	ULTRA 70	M75 x Π42 x Y42	ΝΑΙ
90.067	114	POLAR	M98 x Π44 x Y45	ΝΑΙ



90.060
ΑΝΤΑΛΛΑΚΤΙΚΟ ΚΙΤ
ΓΙΑ ΨΥΓΕΙΟ IGLOO



90.055
ΒΑΣΕΙΣ ΨΥΓΕΙΟΥ IGLOO



90.057
ΑΝΤΑΛΛΑΚΤΙΚΟ ΧΕΡΟΥΛΙ IGLOO



90.058
ΑΝΤΑΛΛΑΚΤΙΚΟ ΚΟΥΜΠΩΜΑ IGLOO



90.059
ΑΝΤΑΛΛΑΚΤΙΚΟΣ ΜΕΝΤΕΣΕΣ IGLOO

ΜΑΞΙΛΑΡΙ ΨΥΓΕΙΟΥ



ΚΩΔΙΚΟΣ	ΜΗΚΟΣ cm	ΠΛΑΤΟΣ cm	ΧΡΩΜΑ
93.290	68	38	ΓΚΡΙ
93.291	73	38	ΓΚΡΙ
93.292	77	41	ΓΚΡΙ
93.293	90	43	ΓΚΡΙ



FUN



FUN



MASTER



RETRO



ΨΥΓΕΙΑ ICEMASTER

ΚΩΔΙΚΟΣ	ΧΩΡΗΤ/ΤΑ lt	MODEL	ΜΗΚΟΣ cm	ΠΛΑΤΟΣ cm	ΥΨΟΣ cm
91.062	25	PRO	37	32	51
91.063	50	PRO	72	37	38
91.064	70	PRO	76	42	45
91.065	120	PRO	90	50	53

ΨΥΓΕΙΑ ICEMASTER

ΚΩΔΙΚΟΣ	lt	MODEL	ΜΗΚΟΣ cm	ΠΛΑΤΟΣ cm	ΥΨΟΣ cm	ΧΡΩΜΑ
91.061A	20	FUN	48	36	34	ΛΕΥΚΟ/ΜΩΒ
91.061B	20	FUN	48	36	34	ΜΠΛΕ/ΘΑΛΑΣΣΙ
91.163	16	MASTER	40	33	29	ΛΕΥΚΟ
91.164	29	MASTER	46	35	41	ΛΕΥΚΟ
91.161A	12	RETRO	41	26	24	ΡΟΖ
91.161B	12	RETRO	41	26	24	ΘΑΛΑΣΣΙ
91.162A	21	RETRO	47	31	28	ΡΟΖ
91.162B	21	RETRO	47	31	28	ΘΑΛΑΣΣΙ

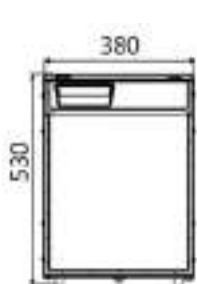

91.071
ΨΥΓΕΙΟ FRIGO 50lit 12-24V

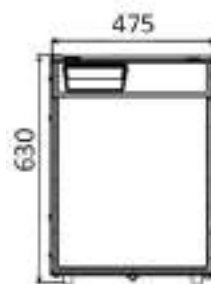

91.072
ΨΥΓΕΙΟ FRIGO 85lit 12-24V

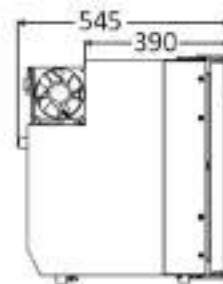

ΨΥΓΕΙΑ ALPICOOOL

Model:	91.081 CR50X	91.082 CR85
Total capacity	43.7L	83L
Rated Power Input	60W	80W
Power Supply	12/24V DC, 100-240V AC	12/24V DC, 100-240V AC
Rated Current	DC-5.0A/2.5A AC-1.2A/0.5A	DC-5.0A/2.5A AC-1.2A/0.5A
Fridge Dimensions (D x W x H)	380 x 479 x 532mm	485 x 455 x 790mm
Net Weight	14.1KG	26KG
Gross Weight	16.1KG	28KG
Fridge/Freezer (Combination)	Fridge: 0°C to 8°C Freezer: -2°C to -12°C	Fridge: 0°C to 8°C Freezer: -20°C to -12°C
Noise Level	<45dB	<45dB



ΨΥΓΕΙΟ ΦΟΡΗΤΟ
91.091 30lt
91.092 40lt



ΒΑΣΗ ΕΞΩΛΕΜΒΙΑΣ ΜΗΧΑΝΗΣ (ΠΛΑΣΤΙΚΟ)

10.749A 20HP
10.750A 25HP (2 ΕΛΑΤΗΡΙΑ)



ΒΑΣΗ ΕΞΩΛΕΜΒΙΑΣ ΜΗΧΑΝΗΣ (ΞΥΛΟ)

10.749B 20HP
10.750B 25HP (2 ΕΛΑΤΗΡΙΑ)



10.744

ΒΑΣΗ ΜΗΧΑΝΗΣ ΕΝΙΣΧΥΜΕΝΗ 50 kg



ΒΑΣΗ ΙΝΟΧ ΓΙΑ ΡΕΛΙΑ

10.756A ΠΛΑΣΤΙΚΟ
10.756B ΞΥΛΟ



10.745

ΒΑΣΗ ΣΤΑΘΕΡΗ ΕΞΩΛΕΜΒΙΑΣ CAN



10.740

ΒΑΣΗ ΜΗΧΑΝΗΣ ΣΤΑΘΕΡΗ L23xW21cm



10.767

ΠΛΑΚΑ ΚΑΘΡΕΠΤΗ 230 x 80 mm

10.768

ΠΛΑΚΑ ΚΑΘΡΕΠΤΗ 270 x 95 mm



10.759

ΠΛΑΚΑ ΣΤΗΡΙΞΗΣ ΜΗΧΑΝΗΣ L43xW35cm

10.760

ΠΛΑΚΑ ΣΤΗΡΙΞΗΣ ΜΗΧΑΝΗΣ ΕΠΙΚΛΙΝΗΣ L42xW34cm (ΣΦΗΝΑ)



10.746

ΒΑΣΗ ΕΞΩΛΕΜΒΙΑΣ ΣΤΑΘΕΡΗ ΠΛΑΣΤΙΚΗ ΡΕΛΙΑ



ΚΛΕΙΔΑΡΙΑ ΜΗΧΑΝΗΣ ΙΝΟΧ

24.501 ΜΙΚΡΗ 25cm
24.502 ΜΕΓΑΛΗ 33cm



24.503

ΚΛΕΙΔΑΡΙΑ ΙΝΟΧ ΜΕ ΚΛΕΙΔΙ ΙΤΑΛΙΑΣ 300 x 42cm



10.755

ΚΑΠΟΝΙ ΣΚΑΦΟΥΣ L150cm



99.561

ΤΡΕΪΛΕΡ ΜΗΧΑΝΗΣ ΕΩΣ 60 kg



99.560

ΤΡΕΪΛΕΡ ΜΗΧΑΝΗΣ 50 kg



99.562

ΤΡΕΪΛΕΡ ΜΗΧΑΝΗΣ ΑΝΑΔΙΠΛΟΥΜΕΝΟ



ΒΑΣΗ ΚΟΤΣΑΝΕΛΟΥ ΠΛΑΣΤΙΚΗ

99.261 150mm

99.262 200mm

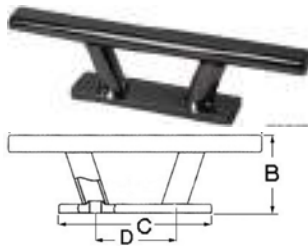

ΚΟΤΣΑΝΕΛΟ NORDIC ΜΑΥΡΟ

ΚΩΔΙΚΟΣ	A mm	B mm	C mm
99.191	150	45	90
99.192	205	55	120

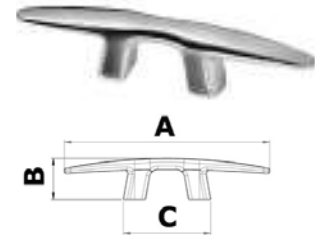

ΚΟΤΣΑΝΕΛΟ ΣΙΛΟΥΕΤΤΕ

ΚΩΔΙΚΟΣ	A mm	B mm	C mm
99.197	150	30.5	63.5
99.198	200	40	85
99.199	250	50	106.5



ΚΟΤΣΑΝΕΛΟ ΙΝΟΧ ΡΟΠ UP

99.205 L134xW38mm

99.206 L185xW50mm



ΚΟΤΣΑΝΕΛΟ ΠΛΑΣΤΙΚΟ

10.825 15cm

10.826 20cm



ΚΟΤΣΑΝΕΛΟ ΙΝΟΧ

99.217 10cm

99.218 15cm

99.215 20cm



ΚΟΤΣΑΝΕΛΟ ΙΝΟΧ ΑΙΣΙ 316 ΜΕ ΒΙΔΑ

99.245 150mm

99.246 200mm

99.247 250mm



ΚΟΤΣΑΝΕΛΟ ΑΛΟΥΜΙΝΙΟΥ ΑΕΡΟ

99.195 15cm

99.196 20cm



ΚΟΤΣΑΝΕΛΟ SS 316 BULL DOG

ΙΝΟΧ	ΜΑΥΡΟ	mm
99.201	99.241	160
99.202	99.242	200
99.203	99.243	250

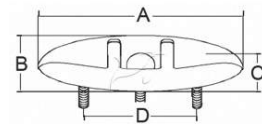

ΚΟΤΣΑΝΕΛΟ ΦΛΑΤ ΑΝΑΔΙΠΛΟΥΜΕΝΟ

ΚΩΔΙΚΟΣ	A mm	B mm	C mm	D mm	S.W.L.
99.249	155	54.7	13.5	85.5	250kg
99.250	202	72.6	15	114	350kg

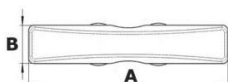

ΚΟΤΣΑΝΕΛΟ ΙΝΟΧ ΦΛΑΤ

ΚΩΔΙΚΟΣ	A mm	B mm
99.265	160mm	34mm
99.266	240mm	44mm

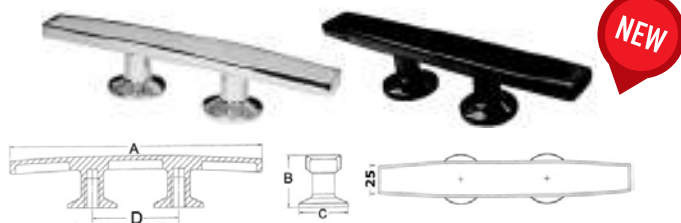

ΚΟΤΣΑΝΕΛΟ SKANDY

ΚΩΔΙΚΟΣ	ΧΡΩΜΑ	A mm	B mm	C mm	D mm
99.181	ΙΝΟΧ	145	30	28	48
99.182	ΙΝΟΧ	190	40	36	70
99.183	ΜΑΥΡΟ	145	30	28	48
99.184	ΜΑΥΡΟ	190	40	36	70



ΧΕΙΡΟΛΑΒΗ INOX
10.7534 220 mm
10.751 310 mm
10.752 390 mm
10.753 450 mm



ΧΕΙΡΟΛΑΒΗ ΜΕ ΒΙΔΑ
10.830 22cm
10.831 30cm
10.832 40cm
10.833 45cm



ΧΕΙΡΟΛΑΒΗ ΜΕ ΣΤΡΟΓΓΥΛΗ ΒΑΣΗ INOX
10.881 20cm
10.882 30cm
10.883 50cm



ΕΞΑΕΡ/ΚΟ ΣΤΡΙΤΣΟΥ INOX
93.171 40x45mm
93.172 55x63mm
93.178 93x87mm



10.801
ΧΕΙΡΟΛΑΒΗ INOX ΜΕ ΒΙΔΑ 17cm



ΧΕΙΡΟΛΑΒΗ ΠΛΑΣΤΙΚΗ
10.889 25cm
10.890 30cm



ΧΕΙΡΟΛΑΒΗ ΜΕ ΒΙΔΑ ΜΑΥΡΟ
10.830B 22cm
10.831B 30cm



93.142
ΧΟΥΦΤΑ ΧΩΝΕΥΤΗ ΚΑΤΑΠΑΚΤΗΣ SS316 50mm ΧΩΡΙΣ ΚΛΕΙΔΙ



93.173
ΧΟΥΦΤΑ ΤΕΤΡΑΓΩΝΗ ΓΙΑ ΚΑΤΑΠΑΚΤΗ SS316 Φ50mm



93.175
ΧΟΥΦΤΑ ΚΑΤΑΠΑΚΤΗΣ INOX SS316 Φ50mm



93.107
ΧΟΥΦΤΑ ΚΑΤΑΠΑΚΤΗΣ INOX SS316 Φ50mm



93.108
ΧΟΥΦΤΑ ΠΑΤΩΜΑΤΟΣ 76x54mm



10.827
ΒΑΣΗ ΡΕΛΙΟΥ Φ22mm 90ο ΜΕ ΣΤΡΟΓΓΥΛΗ ΒΑΣΗ



10.828
ΒΑΣΗ ΡΕΛΙΟΥ Φ22mm 60ο ΜΕ ΣΤΡΟΓΓΥΛΗ ΒΑΣΗ



12.014
ΒΑΣΗ ΛΟΞΗ ΓΙΑ ΡΕΛΙΑ ΠΛΑΣΤΙΚΗ



10.895 - ΒΑΣΗ ΡΕΛΙΟΥ ΑΚΡΗ INOX 22mm
10.896 - ΒΑΣΗ ΡΕΛΙΟΥ ΜΕΣΗ INOX 22mm



10.891
ΒΑΣΗ ΡΕΛΙΟΥ INOX 60° ΟΡΘΟΓΩΝΙΑ Φ22mm



10.892
ΒΑΣΗ ΡΕΛΙΟΥ INOX 90° ΟΡΘΟΓΩΝΙΑ Φ22mm



10.893
ΚΟΜΒΟΣ ΡΕΛΙΟΥ INOX 90ο Φ22mm



10.894
ΚΟΜΒΟΣ ΡΕΛΙΟΥ INOX 60ο Φ22mm



10.900
ΒΑΣΗ ΡΕΛΙΟΥ INOX ΚΟΝΤΗ ΤΕΡΜΑΤΙΚΟ Φ22mm



ΒΑΣΗ ΔΙΑΜΠΕΡΗΣ INOX ΓΙΑ ΚΑΓΚΕΛΟ ΚΟΝΣΟΛΑΣ
10.898 Φ22mm
10.887 Φ25mm



ΒΑΣΗ ΓΙΑ ΚΑΓΚΕΛΟ ΚΟΝΣΟΛΑΣ ΤΕΡΜΑΤΙΚΟ INOX
10.901 Φ22mm
10.902 Φ25mm



ΒΑΣΗ ΓΙΑ ΚΑΓΚΕΛΟ ΤΕΡΜΑΤΙΚΟ INOX Φ22 ΚΟΥΦΙΟ ΔΙΑΜΠΕΡΗΣ INOX Φ22 ΚΟΥΦΙΟ



10.899
ΒΑΣΗ ΡΕΛΙΟΥ INOX ΚΟΝΤΗ ΜΕΣΗ Φ22mm



**ΚΛΕΙΣΤΡΟ ΠΛΑΣΤΙΚΟ
ΑΝΤΙΚΡΑΔΑΣΜΙΚΟ**
L96 x W29mm
93.180A ΛΕΥΚΟ
93.180B ΜΑΥΡΟ



93.168
ΚΛΕΙΣΤΡΟ ΙΝΟΧ ΕΝΙΣΧΥΜΕΝΟ
L70xW28mm



ΚΛΕΙΣΤΡΟ ΙΝΟΧ
93.169 L70xW21mm
93.170 L79xW26mm



93.166
ΚΛΕΙΣΤΡΟ HATCH ΙΝΟΧ
L58mm Φ19mm



93.177
ΚΛΕΙΣΤΡΟ Ν.Τ ΙΝΟΧ
82x25cm ΜΕ ΚΛΕΙΔΙ



93.167
ΚΛΕΙΣΤΡΟ ΙΝΟΧ SLIM NEO
82mm



93.159
ΚΛΕΙΣΤΡΟ ΙΝΟΧ
93x23.5mm



ΚΛΕΙΣΤΡΟ ΙΝΟΧ 93x13mm
93.118 ΜΕ ΚΛΕΙΔΙ ΜΤ
93.119 ΧΩΡΙΣ ΚΛΕΙΔΙ ΜΤ



93.345
ΚΛΕΙΣΤΡΟ ΙΝΟΧ ΝΤ



93.115
ΚΛΕΙΣΤΡΟ MINI 68cm



93.116
ΚΛΕΙΣΤΡΟ Ν.Τ. ΙΝΟΧ 82x25cm
ΜΕ ΥΠΟΔΟΧΗ ΓΙΑ ΛΟΥΚΕΤΟ



93.176
ΚΛΕΙΔΑΡΙΑ ΙΝΟΧ ΠΟΡΤΑΣ
91x56mm

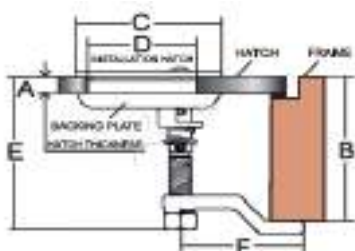

ΚΛΕΙΔΑΡΙΑ ΧΩΝΕΥΤΗ ΓΙΑ ΚΑΤΑΠΑΚΤΗ SS316

ΚΩΔΙΚΟΣ	ΚΛΕΙΔΙ	A (mm)	B (mm)	C (mm)	D (mm)	E (mm)	F (mm)
93.144	ΟΧΙ	5	28-76	64	51	73	54
93.145	ΝΑΙ	5	28-76	64	51	73	54



ΚΛΕΙΣΤΡΟ ΚΑΤΑΠΑΚΤΗΣ
ΙΝΟΧ SS316 Φ62mm
93.174 ΜΕ ΚΛΕΙΔΙ
93.147 ΧΩΡΙΣ ΚΛΕΙΔΙ

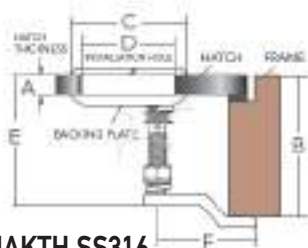

ΚΛΕΙΔΑΡΙΑ ΧΩΝΕΥΤΗ ΓΙΑ ΚΑΤΑΠΑΚΤΗ SS316

ΚΩΔΙΚΟΣ	ΚΛΕΙΔΙ	A (mm)	B (mm)	C (mm)	D (mm)	E (mm)	F (mm)
94.134	ΟΧΙ	6~20	25~76	65	51	71	54
94.135	ΝΑΙ	6~20	25~76	65	51	71	54
94.136	ΟΧΙ	5~14	25~76	53	38	70	54
94.137	ΝΑΙ	5~14	25~76	53	38	70	54



93.201
ΚΛΕΙΔΑΡΙΑ ΚΑΤΑΠΑΚΤΗΣ
ΠΛΑΣΤΙΚΗ
A ΛΕΥΚΟ- B ΜΑΥΡΟ



93.123A

ΜΕΝΤΕΣΕΣ 6 ΤΡΥΠΕΣ ΜΕ ΚΑΠΑΚΙ

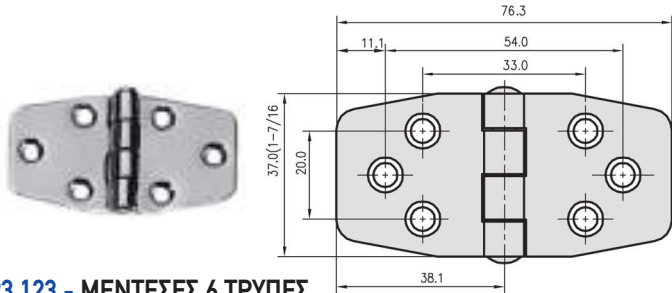
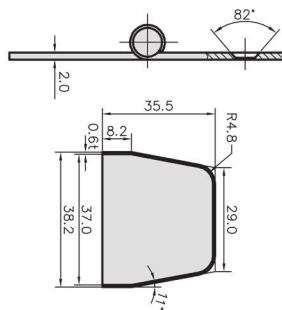
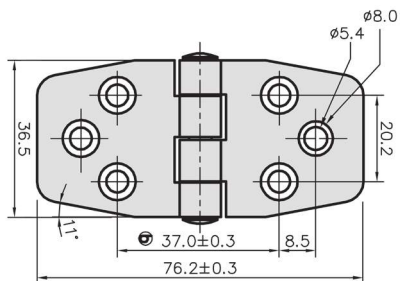

93.123 - ΜΕΝΤΕΣΕΣ 6 ΤΡΥΠΕΣ

93.124 - ΜΕΝΤΕΣΕΣ 6 ΤΡΥΠΕΣ ΑΝΑΠΟΔΟΣ

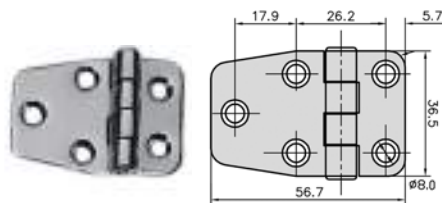

93.122 - ΜΕΝΤΕΣΕΣ 5 ΤΡΥΠΕΣ

93.121 - ΜΕΝΤΕΣΕΣ 5 ΤΡΥΠΕΣ ΑΝΑΠΟΔΟΣ

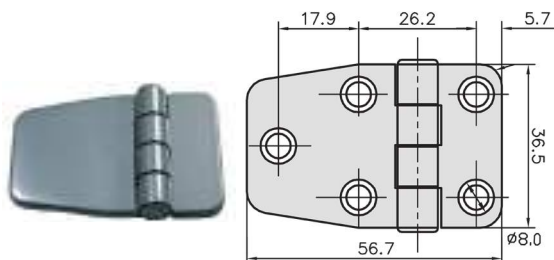

93.125

ΜΕΝΤΕΣΕΣ 5 ΤΡΥΠΕΣ ΜΕ ΚΑΠΑΚΙ

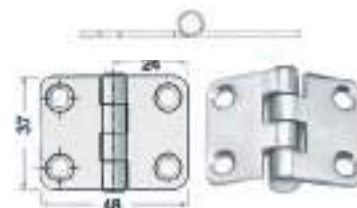
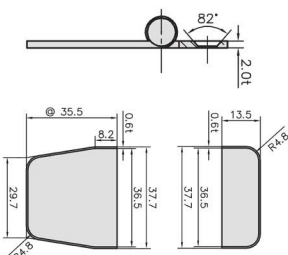

93.146 ΜΕΝΤΕΣΕΣ 4 ΤΡΥΠΕΣ ΠΑΡΑΛ/ΜΟΣ

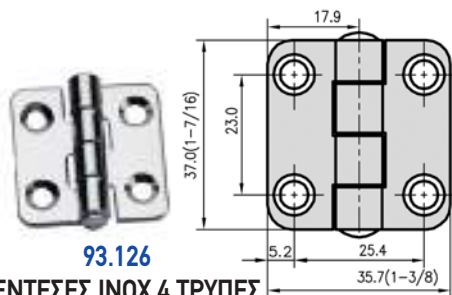

93.126

ΜΕΝΤΕΣΕΣ ΙΝΟΧ 4 ΤΡΥΠΕΣ



93.127

ΜΕΝΤΕΣΕΣ ΙΝΟΧ 6 ΤΡΥΠΕΣ

93.134

ΜΕΝΤΕΣΕΣ ΙΝΟΧ 6 ΤΡΥΠΕΣ ΑΝΑΠΟΔΟΥ



93.138

**ΜΕΝΤΕΣΕΣ ΙΝΟΧ 4 ΤΡΥΠΕΣ
L36,5 x W66.6mm**



93.041

**ΜΕΝΤΕΣΕΣ ΜΑΥΡΟΣ PVD
3" x 1 1/12"**



93.042

**ΜΕΝΤΕΣΕΣ ΜΑΥΡΟΣ PVD
4" x 1 1/12"**



93.122B

**ΜΕΝΤΕΣΕΣ ΙΝΟΧ 40x60
5 ΤΡΥΠΕΣ ΜΑΥΡΟ**



93.123B

**ΜΕΝΤΕΣΕΣ 40x77 6
ΤΡΥΠΕΣ ΜΑΥΡΟ**



93.126B

**ΜΕΝΤΕΣΕΣ 40x40mm
4 ΤΡΥΠΕΣ ΜΑΥΡΟ**

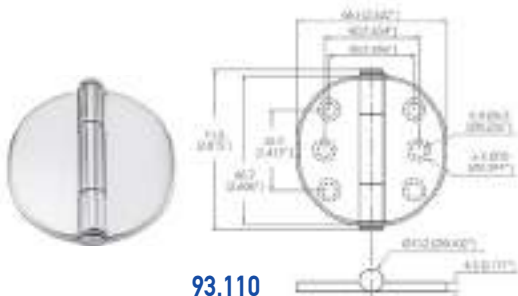

93.110

ΜΕΝΤΕΣΕΣ FRICTION ΣΤΡΟΓΓΥΛΟΣ ΜΕ ΚΑΠΑΚΙ



93.149

ΜΕΝΤΕΣΕΣ ΒΤ ΚΑΘΙΣΜΑΤΟΣ ΙΝΟΧ (ΖΕΥΓΟΣ)



93.150

ΒΑΣΗ ΓΙΑ ΚΑΘΙΣΜΑ ΣΤΗΡΙΓΜΑΤΟΣ ΧΕΡΙΟΥ



93.112

ΜΕΝΤΕΣΕΣ FRICTION 3x3



93.111

ΜΕΝΤΕΣΕΣ FRICTION 3x2



93.113

ΜΕΝΤΕΣΕΣ FRICTION 6 ΤΡΥΠΕΣ

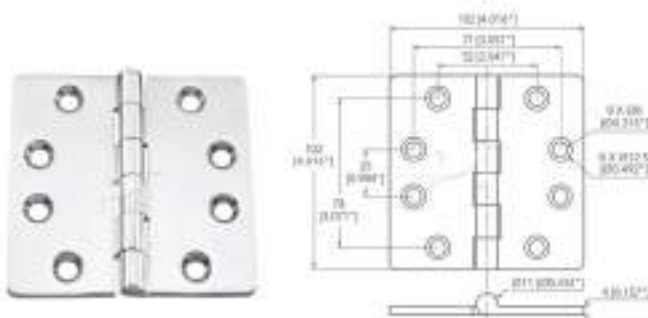

93.148 ΜΕΝΤΕΣΕΣ 8 ΤΡΥΠΕΣ ΤΕΤΡΑΓΩΝΟΣ 102x102mm



93.135

ΜΕΝΤΕΣΕΣ Β.Τ. 6 ΤΡΥΠΕΣ L78xW51xH3.2mm



93.128 - ΜΕΝΤΕΣΕΣ ΒΤ 5 ΤΡΥΠΕΣ L57xW40xH3.2mm



93.137

ΜΕΝΤΕΣΕΣ ΒΤ 6 ΤΡΥΠΕΣ 127x127x3.2mm



93.136

ΜΕΝΤΕΣΕΣ Β.Τ. 6 ΤΡΥΠΕΣ L106xW38xH3.2mm



93.129

ΜΕΝΤΕΣΕΣ ΒΤ 5 ΤΡΥΠΕΣ L40xW75xH3.2mm ΜΑΚΡΥΣ



93.765

ΔΑΧΤΥΛΙΟΣ ΔΥΝΕΕΜΑ
QUICK ΜΠΑΛΟΝΙΟΥ



93.761

ΓΑΝΤΖΟΣ ΙΝΟΧ ΜΠΑΛΟΝΙΟΥ QUICK
39 X 30



93.764

ΓΑΝΤΖΟΣ QUICK ΙΝΟΧ ΜΑΥΡΟΣ
ΜΠΑΛΟΝΙΟΥ QUICK 39 X 30



93.762

ΒΑΣΗ QUICK ΙΝΟΧ ΜΠΑΛΟΝΙΟΥ
33 X 53mm



93.763

ΒΑΣΗ QUICK ΙΝΟΧ ΜΑΥΡΗ ΜΠΑΛΟΝΙΟΥ
33 X 53mm



99.784

ΓΑΝΤΖΟΣ ΣΥΓΚΡΑΤΗΣΗΣ
ΣΧΟΙΝΙΟΥ 52x35mm



99.785

ΓΑΝΤΖΟΣ ΣΥΓΚΡΑΤΗΣΗΣ
ΜΠΑΛΟΝΙΟΥ 52x35mm



99.765

ΠΑΤΗΜΑ ΙΝΟΧ
L111xH124mm



99.786

ΓΑΝΤΖΟΣ ΚΡΕΜΑΣΤΡΑ
ΑΝΑΔΙΠΛΟΥΜΕΝΟΣ 50x28mm



99.763

ΓΑΝΤΖΟΣ ΙΝΟΧ
ΜΠΑΛΟΝΙΟΥ ΣΤΡΟΓΓΥΛΟΣ



ΓΑΝΤΖΟΣ ΙΝΟΧ
ΜΠΑΛΟΝΙΟΥ
PULL UP ΣΧΟΙΝΙ
99.762 Φ34 6 - 8mm



93.251

ΣΥΣΤΗΜΑ ΣΥΓΚΡΑΤΗΣΗΣ
ΠΟΡΤΑΣ ΜΑΓΝΗΤΙΚΟ



93.252

ΣΥΣΤΗΜΑ ΣΥΓΚΡΑΤΗΣΗΣ ΠΟΡΤΑΣ
ΜΑΓΝΗΤΙΚΟ 60x35mm



93.202

ΣΥΣΤΗΜΑ ΚΛΕΙΣΙΜΑΤΟΣ ΙΝΟΧ



93.179

ΚΟΥΜΠΩΜΑ ΠΟΡΤΑΣ ΙΝΟΧ
50 x9mm



ΚΟΥΜΠΩΜΑ ΧΑΤΣ ΠΛΑΣΤΙΚΟ

ΚΩΔ.	A mm	B mm	C mm	D mm	ΔΥΝΑΜΗ ΣΥΓΚΡΑΤΗΣΗΣ
93.361	21	20	12.5	13.5	8 kg
93.362	21	20	12.5	13.5	16 kg
93.363	39	31	25.4	27	10 kg
93.364	39	31	25.4	27	17 kg



ΚΟΥΜΠΩΜΑ ΧΑΤΣ

ΚΩΔ.	A mm	B mm	C mm	D mm	E mm	ΔΥΝΑΜΗ ΣΥΓΚΡΑΤΗΣΗΣ
93.341	46	0-130	39	13.5	13	8 kg



ΚΟΥΜΠΩΜΑ ΧΑΤΣ

ΚΩΔ.	A mm	B mm	C mm	D mm	E mm	ΔΥΝΑΜΗ ΣΥΓΚΡΑΤΗΣΗΣ
93.342	16.5	16	32	20	21	8 kg



ΜΑΠΑ ΤΥΠΟΥ U

- 93.160 M6 x 90mm
- 93.161A M8 x 80mm
- 93.161B M8 x 100mm
- 93.162 M10 x 130mm
- 93.164 M12 x 150mm



93.163

ΜΑΠΑ ΤΥΠΟΥ U
M10 BT x 130mm



93.165

ΜΑΠΑ ΤΥΠΟΥ U Β.Τ. ΙΝΟΧ
M16x160mm



ΜΑΠΑ Ω ΙΝΟΧ

- 93.157 4mm
- 93.158 5mm
- 93.152 6mm
- 93.153 8mm



ΜΑΠΑ ΜΕ ΒΑΣΗ ΙΝΟΧ

- 93.155 5mm 30x35mm
- 93.156 6mm 35x40mm



93.154

ΜΑΠΑ ΙΝΟΧ ΙΜΑΝΤΑ
40mm L55mm Ø5mm



93.114

ΜΑΠΑ ΙΝΟΧ 30mm



ΠΟΡΤΑΚΙ ΝΕΟ L38xW38cm
2ΠΛΗΣ ΕΦΑΡΜΟΓΗΣ
11.802 A - ΛΕΥΚΟ
11.802 B - ΜΑΥΡΟ
11.802 C - ΓΚΡΙ



ΠΟΡΤΑΚΙ ΝΕΟ L28 x W38cm
2ΠΛΗΣ ΕΦΑΡΜΟΓΗΣ
11.801 A - ΛΕΥΚΟ
11.801 B - ΜΑΥΡΟ
11.801 C - ΓΚΡΙ

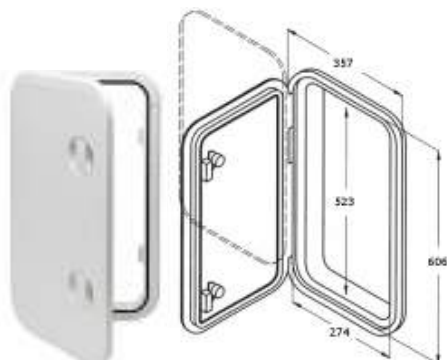

ΠΟΡΤΑΚΙ ΝΕΟ L60 x W36cm
2ΠΛΗΣ ΕΦΑΡΜΟΓΗΣ
11.803 A - ΛΕΥΚΟ
11.803 B - ΜΑΥΡΟ
11.803 C - ΓΚΡΙ

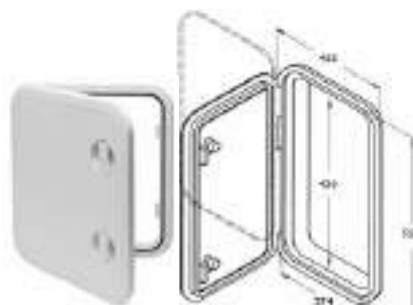

ΠΟΡΤΑΚΙ ΝΕΟ L52 x W47 cm
2ΠΛΗΣ ΕΦΑΡΜΟΓΗΣ
11.804 A - ΛΕΥΚΟ
11.804 B - ΜΑΥΡΟ
11.804 C - ΓΚΡΙ

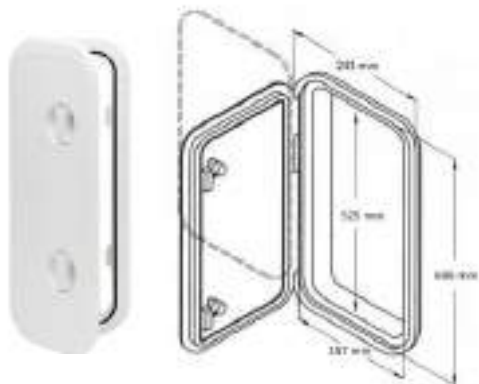

ΠΟΡΤΑΚΙ ΝΕΟ L25 xW60cm
2ΠΛΗΣ ΕΦΑΡΜΟΓΗΣ
11.805 A - ΛΕΥΚΟ
11.805 B - ΜΑΥΡΟ
11.805 C - ΓΚΡΙ

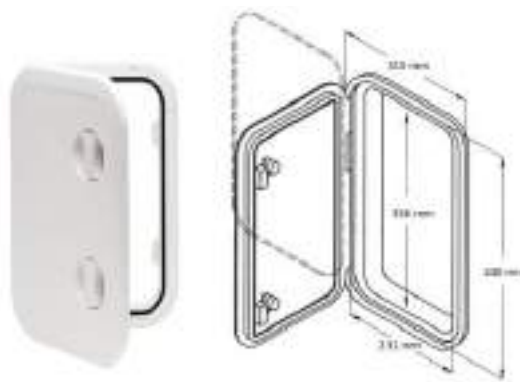

ΠΟΡΤΑΚΙ ΝΕΟ L32 x W44cm
2ΠΛΗΣ ΕΦΑΡΜΟΓΗΣ
11.807 A - ΛΕΥΚΟ
11.807 B - ΜΑΥΡΟ
11.807 C - ΓΚΡΙ





10.813

ΝΤΟΥΛΑΠΙ ΜΕ ΠΟΡΤΑΚΙ 2ΠΛΗΣ
ΕΦΑΡΜΟΓΗΣ L38xW28xD16cm



10.814

ΝΤΟΥΛΑΠΙ ΜΕ ΠΟΡΤΑΚΙ 2ΠΛΗΣ
ΕΦΑΡΜΟΓΗΣ L46xW52xD33cm



10.815

ΝΤΟΥΛΑΠΙ ΜΕ ΠΟΡΤΑΚΙ 2ΠΛΗΣ
ΕΦΑΡΜΟΓΗΣ L38xW38xD25cm



10.816

ΝΤΟΥΛΑΠΙ ΜΕ ΠΟΡΤΑΚΙ 2ΠΛΗΣ
ΕΦΑΡΜΟΓΗΣ L60xW36xD32cm



11.809

ΠΟΡΤΑΚΙ 30x18cm
Α ΛΕΥΚΟ
Β ΜΑΥΡΟ
C ΓΚΡΙ



10.841

ΑΝΤΑΛΑΚΤΙΚΗ
ΚΛΕΙΔΑΡΙΑ ΓΙΑ
ΠΟΡΤΑΚΙΑ



ΑΝΤΑΛ/ΚΟ ΜΕ ΚΛΕΙΔΑΡΙΑ
ΓΙΑ ΠΟΡΤΑΚΙΑ
10.840 Α - ΛΕΥΚΟ
10.840 Β - ΜΑΥΡΟ
10.840 C - ΓΚΡΙ



10.842

ΑΝΤΑΛ/ΚΟ ΓΙΑ ΠΟΡΤΑΚΙ
Α ΛΕΥΚΟ
Β ΜΑΥΡΟ
C ΓΚΡΙ



10.806

ΚΛΕΙΔΑΡΙΑ
ΓΙΑ ΠΟΡΤΑΚΙΑ



ΗΑΤΗ ΣΤΡΟΓΓΥΛΟ Φ21
11.831Α ΛΕΥΚΟ / 11.831Β ΜΑΥΡΟ



ΗΑΤΗ ΣΤΡΟΓΓΥΛΟ Φ26
11.832Α ΛΕΥΚΟ / 11.832Β ΜΑΥΡΟ



ΗΑΤΗ ΣΤΡΟΓΓΥΛΟ Φ32
11.833Α ΛΕΥΚΟ / 11.833Β ΜΑΥΡΟ



11.834
ΗΑΤΗ ΟΡΘΟΓΩΝΙΟ 20X40 ΛΕΥΚΟ



15.801
ΠΟΡΤΑΚΙ 27X38 ΜΕ ΚΛΕΙΔΙ



15.802
ΠΟΡΤΑΚΙ 37X38 ΜΕ ΚΛΕΙΔΙ



15.803
1ΠΟΡΤΑΚΙ 36X60 ΜΕ ΚΛΕΙΔΙ



15.804
ΠΟΡΤΑΚΙ 46X52 ΜΕ ΚΛΕΙΔΙ



15.805
ΠΟΡΤΑΚΙ 25X60 ΜΕ ΚΛΕΙΔΙ



15.807
ΠΟΡΤΑΚΙ 32X44 ΜΕ ΚΛΕΙΔΙ



ΕΞΑΕΡΙΣΤΙΚΟ ΠΛΑΣΤΙΚΟ
10.678 L85xW85mm
10.679 L125xW125mm

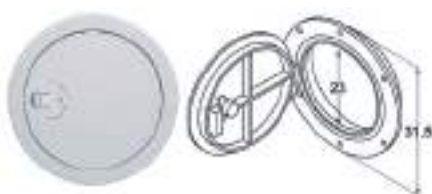

10.805
ΠΟΡΤΑΚΙ ΣΤΡΟΓΓΥΛΟ Φ32cm



10.804
ΠΟΡΤΑΚΙ ΣΤΡΟΓΓΥΛΟ Φ27cm

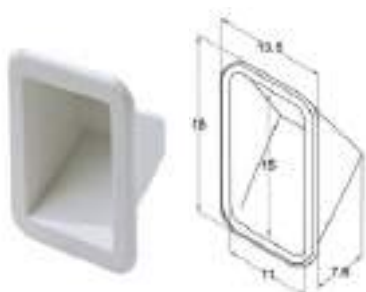

10.362
ΝΤΟΥΛΑΠΙ ΓΩΝΙΑΚΟ

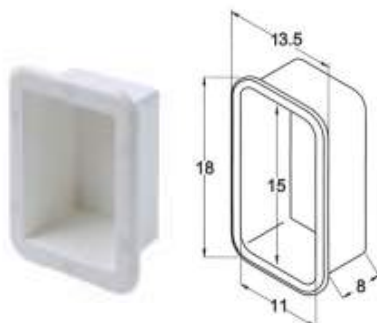

10.361
ΝΤΟΥΛΑΠΙ ΜΙΚΡΟ



10.808
ΝΤΟΥΛΑΠΙ ΜΕ ΠΟΡΤΑ (ΠΥΡΟΣΒΕΣΤΗΡΑ)



ΝΤΟΥΛΑΠΙ ΜΕ ΧΩΡΙΣΜΑ
11.819A - ΛΕΥΚΟ
11.819B - ΜΑΥΡΟ



ΤΑΠΑ ΕΠΙΘΕΩΡΗΣΗΣ
(A Λευκή - B Μαύρη - C Γκρι)
11.597 102-160mm
11.598 127-185mm
11.599 152-210mm



ΤΑΠΑ ΕΠΙΘΕΩΡΗΣΗΣ
11.601 102-160mm
11.602 127-185mm
11.603 152-210mm

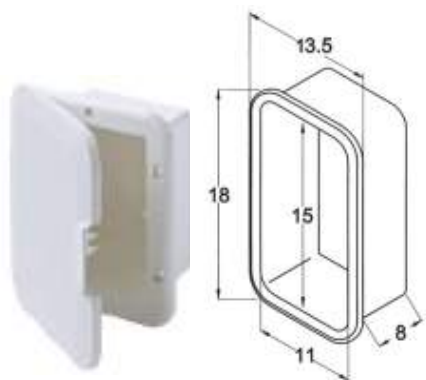

10.817
ΝΤΟΥΛΑΠΙ ΜΕ ΠΟΡΤΑ ΜΙΚΡΟ

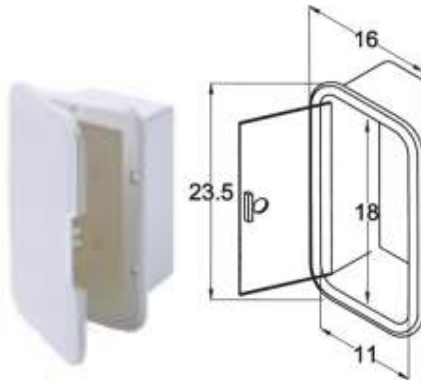

10.818
ΝΤΟΥΛΑΠΙ ΜΕ ΠΟΡΤΑ ΜΕΣΑΙΟ



10.809
ΝΤΟΥΛΑΠΑΚΙ ΜΕ ΔΙΑΦΑΝΗ ΠΟΡΤΑ



ΚΟΥΡΤΙΝΑΚΙ HATCH

- 90.501 L36xH40cm No1
- 90.502 L45xH50cm No2
- 90.503 L50xH60cm No3
- 90.504 L55xH65cm No4



11.847



11.887



11.897

HATCH ΣΤΡΟΓΓΥΛΟ

ΚΩΔΙΚΟΣ	ΔΙΑΣΤ. ΚΟΠΗΣ mm	ΔΙΑΣΤ. ΕΞΩΤΕΡΙΚΕΣ mm	ΘΗΚΗ HATCH	ΣΚΙΑΣΤΡΟ HATCH
11.847	418	490	11.887	11.897
11.848	478	548	11.888	11.898
11.849	520	591	11.889	11.899



11.850



11.851



11.860



11.870

HATCH ΑΛΟΥΜΙΝΙΟΥ ΧΑΜΗΛΟΥ ΠΡΟΦΙΛ*

ΚΩΔΙΚΟΣ	ΔΙΑΣΤ. ΚΟΠΗΣ mm	ΔΙΑΣΤ. ΕΞΩΤΕΡΙΚΕΣ mm	ΘΗΚΗ HATCH	ΣΚΙΑΣΤΡΟ HATCH
11.850	176 x 231	246x301	11.860	11.870
11.851	260 x 260	330x330	11.861	11.871
11.852	202 x 347	272x417	11.862	11.872
11.853	457 x 327	527x397	11.863	11.873
11.854	421 x 421	491x491	11.864	11.874
11.855	442 x 442	512x512	11.865	11.875
11.856	507 x 392	577x462	11.866	11.876
11.857	507 x 507	577x577	11.867	11.877

*ALSO IN BLACK COLOUR



ΣΚΑΛΑ ΑΛΟΥΜΙΝΙΟΥ

- 10.781 2 ΣΚΑΛΙΑ
- 10.782 3 ΣΚΑΛΙΑ
- 10.783 4 ΣΚΑΛΙΑ
- 10.784 5 ΣΚΑΛΙΑ



ΣΚΑΛΑ ΙΝΟΧ

- 10.774 3 ΣΚΑΛΙΑ SS 316 W20 x L63cm ΣΤΕΝΗ
- 10.778 3 ΣΚΑΛΙΑ SS 316 W25 x L63cm
- 10.779 4 ΣΚΑΛΙΑ SS 316 W25 x L90cm



ΣΚΑΛΑ ΙΝΟΧ ΞΥΛΙΝΑ ΣΚΑΛΙΑ

- 10.771 3 ΣΚΑΛΙΑ W23 x L56cm
- 10.772 4 ΣΚΑΛΙΑ W23 x L76cm
- 10.773 5 ΣΚΑΛΙΑ W23 x L105cm



ΣΚΑΛΑ ΓΥΡΙΣΤΗ ΙΝΟΧ SS316

- 10.947 3 ΣΚΑΛΙΑ W25 x L67cm
- 10.948 4 ΣΚΑΛΙΑ W25 x L91cm
- 10.951 5 ΣΚΑΛΙΑ W25 x L105cm



10.762

ΠΛΑΤΦΟΡΜΑ ΜΕ 3 ΣΚΑΛΙΑ
ΙΝΟΧ W20 x L39cm



10.763

ΠΛΑΤΦΟΡΜΑ ΞΥΛΙΝΗ ΙΝΟΧ
27x39cm



NEW



10.770

ΣΚΑΛΑ ΦΟΥΣΚΩΤΩΝ
ΤΗΛΕΣΚΟΠΙΚΗ ΙΝΟΧ 4 ΣΚΑΛΙΑ



10.785

ΣΚΑΛΑ ΑΛΟΥΜΙΝΙΟΥ
ΜΕ ΣΧΟΙΝΙ



10.792

ΣΚΑΛΑ ΑΠΟ ΣΧΟΙΝΙ
ΧΩΝΕΥΤΗ ΠΛΑΣΤΙΚΗ



10.787

ΣΚΑΛΑ ΑΠΟΣΠΩΜΕΝΗ
ΜΕ 3 ΣΚΑΛΙΑ ΙΝΟΧ ΑΙΣΙ316
W36 x L91cm



10.791

ΒΑΣΗ ΙΝΟΧ ΑΠΟΣΠ. ΣΚΑΛΑΣ

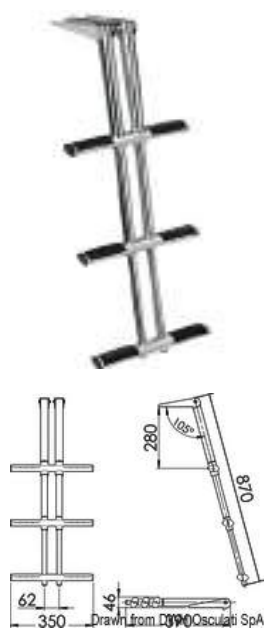

ΣΚΑΛΑ ΤΗΛΕΣΚΟΠΙΚΗ ΙΝΟΧ

10.790 3 ΣΚΑΛΙΑ

10.793 4 ΣΚΑΛΙΑ



10.765

10.766

ΣΚΑΛΑ ΤΗΛΕΣΚΟΠΙΚΗ ΑΠΟΣΠΩΜΕΝΗ

10.765 3 ΣΚΑΛΙΑ

10.766 4 ΣΚΑΛΙΑ



ΣΚΑΛΑ ΣΕ ΚΟΥΤΙ ΙΝΟΧ SS316

10.786 3 ΣΚΑΛΙΑ W25 x L87cm

10.788 4 ΣΚΑΛΙΑ W25 x L114cm



ΣΚΑΛΑ ΤΗΛΕΣΚΟΠΙΚΗ ΠΑΣΑΡΕΛΑΣ ΜΕ ΛΑΒΗ

10.941 3 ΣΚΑΛΙΑ

10.942 4 ΣΚΑΛΙΑ



ΣΚΑΛΑ ΤΗΛΕΣΚΟΠΙΚΗ ΠΛΑΤΦΟΡΜΑΣ ΙΝΟΧ SS 316

10.775 3 ΣΚΑΛΙΑ W20xL87cm

10.780 3 ΣΚΑΛΙΑ W28xL87cm

10.789 4 ΣΚΑΛΙΑ W28xL114cm



ΣΚΑΛΑ ΤΗΛΕΣΚΟΠΙΚΗ ΙΝΟΧ SS 316

10.945 3 ΣΚΑΛΙΑ W20 x L87cm ΣΤΕΝΗ

10.776A 3 ΣΚΑΛΙΑ W28 x L87cm ΛΕΥΚΟ

10.776B 3 ΣΚΑΛΙΑ W28 x L87cm ΜΑΥΡΟ

10.777A 4 ΣΚΑΛΙΑ W28 x L114cm ΛΕΥΚΟ

10.777B 4 ΣΚΑΛΙΑ W28 x L114cm ΜΑΥΡΟ



ΣΚΑΛΑ ΤΗΛΕΣΚΟΠΙΚΗ ΜΑΥΡΗ

11.776 3 ΣΚΑΛΙΑ

11.777 4 ΣΚΑΛΙΑ

90.302
ΠΑΣΑΡΕΛΑ
ΑΛΟΥΜΙΝΙΟΥ
ΣΠΑΣΤΗ
L230xW37cm
16 kg



ΠΑΣΑΡΕΛΑ ΑΛΟΥΜΙΝΙΟΥ
90.304 L200xW37cm 15 kg
90.305 L230xW37cm 16 kg

90.310
ΠΑΣΑΡΕΛΑ
2.2mt
ΠΤΥΣΣΟΜΕΝΗ
Polybridge II
8kg



NEW

90.319
ΞΥΛΙΝΟ
ΠΑΤΩΜΑ
ΠΑΣΑΡΕΛΑΣ



ΠΑΣΑΡΕΛΑ ΜΕ ΤΕΑΚ

90.306 L200xW37cm 15 kg
90.307 L230xW37cm 16 kg



90.309
ΠΑΣΑΡΕΛΑ
ΜΕ ΤΕΑΚ
ΣΠΑΣΤΗ
L250xW37cm
18kg



90.311
ΠΑΣΑΡΕΛΑ ΦΟΥΣΚΩΤΗ
T-WAVE L200cm x W67cm

NEW



90.318
ΤΡΙΓΩΝΟ ΣΤΗΡΙΞΗΣ
ΠΑΣΑΡΕΛΑΣ



90.315
ΚΟΛΩΝΑΚΙΑ
ΠΑΣΑΡΕΛΑΣ
ΙΝΟΧ

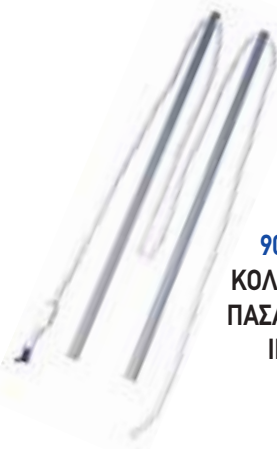

90.317
ΑΝΤΑΛΛΑΚΤΙΚΑ
ΠΑΣΑΡΕΛΑΣ



90.314
ΡΟΔΑΚΙ
ΠΑΣΑΡΕΛΑΣ



90.316
ΒΑΣΗ ΑΛΟΥΜΙΝΙΟΥ
ΠΑΣΑΡΕΛΑΣ



10.797
ΑΝΤΑΛΛΑΚΤΙΚΟ ΣΚΑΛΑΣ
ΚΟΜΒΟΣ ΙΝΟΧ 22mm



10.795
ΑΝΤΑΛΛΑΚΤΙΚΟ
ΣΚΑΛΑΣ U ΙΝΟΧ 22mm



10.799
ΑΝΤΑΛΛΙΚΗ ΒΑΣΗ
ΣΚΑΛΑΣ ΙΝΟΧ



10.794
ΑΝΤΑΛΛΑΚΤΙΚΟ
ΠΟΔΑΡΑΚΙ ΣΚΑΛΑΣ





90.041
T-TOP ΑΛΟΥΜΙΝΙΟΥ Φ32mm

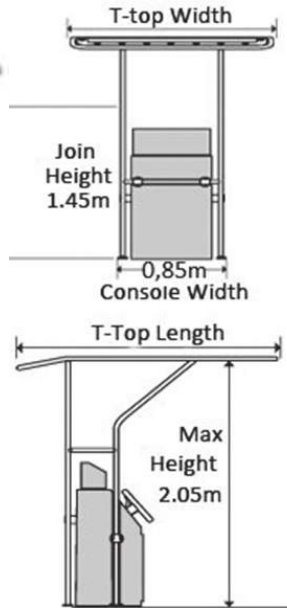

90.087
ΑΝΤΑΛΛΑΚΤΙΚΟ T
TOP Φ32 T JOINER



90.089
ΑΝΤΑΛΛΑΚΤΙΚΟ T TOP
Φ32 ΒΑΣΗ



90.088
ΑΝΤΑΛΛΑΚΤΙΚΟ T TOP
Φ32 ΒΑΣΗ



90.090
ΑΝΤΑΛΛΑΚΤΙΚΟ T TOP
Φ32 JOINER 900



90.091
ΑΝΤΑΛΛΑΚΤΙΚΟ T TOP
Φ32 ΒΑΣΗ



90.086
ΑΝΤΑΛ/ΚΟ T TOP Φ32
ΦΩΤΑ ΠΟΡΕΙΑΣ



90.042
T-TOP ΑΛΟΥΜΙΝΙΟΥ ΕΝΙΣΧΥΜΕΝΟ Φ44mm

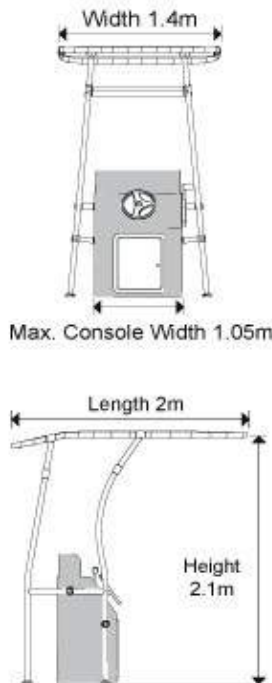

90.081
ΑΝΤΑΛ/ΚΟ T TOP Φ44
ΦΩΤΑ ΠΟΡΕΙΑΣ



90.085
ΑΝΤΑΛ/ΚΟ T TOP
Φ44 ΒΑΣΗ



90.084
ΑΝΤΑΛ/ΚΟ T TOP Φ44
ΠΑΝΩ BOTTOM



90.082
ΑΝΤΑΛ/ΚΟ T TOP
Φ44 T JOINER



90.083
ΑΝΤΑΛ/ΚΟ T TOP Φ44
ΠΛΑΙΝΟ BOTTOM



ΡΟΛ ΜΠΑΡ ΓΙΑ ΦΟΥΣΚΩΤΟ
90.028 Φ30mm L162-210cm
90.030 Φ40mm L162-210cm
90.032 Φ50mm L162-210cm



ΡΟΛ ΜΠΑΡ ΓΙΑ ΠΟΛΥΕΣΤΕΡΙΚΟ ΣΚΑΦΟΣ
90.029 Φ30mm L162-210cm
90.031 Φ40mm L162-210cm
90.033A Φ50mm L162-210cm
90.033B Φ50mm L205-240cm

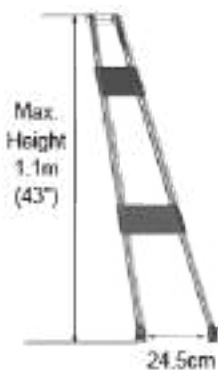

90.027 ΡΟΛ ΜΠΑΡ ΙΝΟΧ 32mm



ΡΟΛ ΜΠΑΡ ΓΙΑ ΠΟΛΥΕΣΤΕΡΙΚΟ ΣΚΑΦΟΣ
90.043 Φ40mm L162 -210cm



ΤΕΝΤΑ ΑΛΟΥΜΙΝΙΟΥ ΜΕ 2 ΑΝΤΙΡΙΔΕΣ

ΚΩΔΙΚΟΣ	ΠΛΑΤΟΣ mt	ΜΗΚΟΣ mt	ΔΙΑΜ. ΣΩΛΗΝΑ mm
12.541	1,30-1,50	1,70	25
12.542	1,50-1,70	1,70	25



ΤΕΝΤΑ ΑΛΟΥΜΙΝΙΟΥ ΣΠΑΣΤΗ

ΚΩΔΙΚΟΣ	ΠΛΑΤΟΣ mt	ΜΗΚΟΣ mt	ΔΙΑΜ. ΣΩΛΗΝΑ mm
12.004	1,40	1,80	22
12.005	1,60	2,00	22
12.006	1,80	2,20	22



ΤΕΝΤΑ ΑΛΟΥΜΙΝΙΟΥ ΜΕ 4 ΑΝΤΙΡΙΔΕΣ

ΚΩΔΙΚΟΣ	ΠΛΑΤΟΣ mt	ΜΗΚΟΣ mt	ΔΙΑΜ. ΣΩΛΗΝΑ mm
12.550	1,5-1,7	2,2	25
12.551	1,7-1,9	2,2	25
12.552	1,9-2,1	2,2	25
12.553	2,1-2,3	2,2	25



ΤΕΝΤΑ ΑΛΟΥΜΙΝΙΟΥ ΜΕ 3 ΑΝΤΙΡΙΔΕΣ

ΚΩΔΙΚΟΣ	ΠΛΑΤΟΣ mt	ΜΗΚΟΣ mt	ΔΙΑΜ. ΣΩΛΗΝΑ mm
12.561	1,5-1,7	1,83	25
12.562	1,7-1,9	1,83	25
12.563	1,9-2,1	1,83	25



12.555

ΑΝΤΙΡΙΔΕΣ ΤΕΝΤΑΣ 110cm



ΕΝΣΩΜΑΤΩΜΕΝΟ ΚΑΛΥΜΑ ΤΕΝΤΑΣ

*ΔΙΑΘΕΣΙΜΕΣ ΣΕ 4 ΧΡΩΜΑΤΑ

*ΙΔΑΝΙΚΕΣ ΓΙΑ ΤΑΞΙΔΕΜΑ ΕΩΣ 45 knots



BLACK BK



BLUE B



SAND S



MAROON M



GREY G



96.302 ΤΕΝΤΑ ΙΣΤΙΟΠΛΟΙΚΟΥ 3,0x3,2 m

96.303 ΤΕΝΤΑ ΙΣΤΙΟΠΛΟΙΚΟΥ 3,6x4,2 m



12.017

ΑΡΘΡΩΣΗ ΤΕΝΤΑΣ (ΖΕΥΓΟΣ)



12.012

ΒΑΣΗ ΣΠΑΣΤΗ ΤΕΝΤΑΣ (ΖΕΥΓΟΣ)



12.018

ΒΑΣΗ ΤΕΝΤΑΣ ΦΟΥΣΚΩΤΟΥ (ΖΕΥΓΟΣ)



12.015

ΣΠΑΣΤΗ ΑΡΘΡΩΣΗΣ ΤΕΝΤΑΣ (ΖΕΥΓΟΣ)



12.570

ΑΝΤΑΛ/ΚΟ ΤΕΝΤΑΣ ΑΡΘΡΩΣΗ OCS



12.571

ΑΝΤΑΛ/ΚΟ ΒΑΣΗΣ ΣΤΑΘΕΡΗΣ ΤΕΝΤΑΣ OCS



12.572

ΑΝΤΑΛΛΑΚΤΙΚΟ ΒΑΣΗΣ ΤΕΝΤΑΣ ΦΟΥΣΚΩΤΟΥ OCS



12.573

ΑΝΤΑΛ/ΚΟ ΤΕΝΤΑΣ ΙΜΑΝΤΑΣ OCS (ΖΕΥΓΟΣ)



A ΜΠΛΕ-ΓΚΡΙ



B.ΓΚΡΙ-ΛΕΥΚΟ



A. ΓΚΡΙ-ΑΝΘΡΑΚΙ



B.ΛΕΥΚΟ-ΓΚΡΙ



C. ΓΚΡΙ-ΑΝΘΡΑΚΙ



C. ΛΕΥΚΟ-ΜΠΛΕ

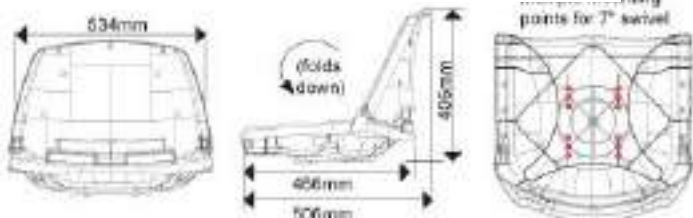

93.093 ΚΑΘΙΣΜΑ ΣΚΑΦΟΥΣ ΑΝΑΔΙΠΛΟΥΜΕΝΟ

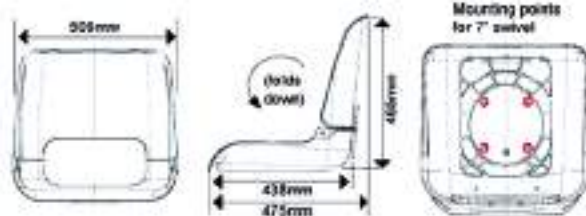

93.094 ΚΑΘΙΣΜΑ SKIPPER



A. ΓΚΡΙ-ΑΝΘΡΑΚΙ



B.ΓΚΡΙ



A. ΓΚΡΙ-ΑΝΘΡΑΚΙ



B.ΛΕΥΚΟ



C. ΛΕΥΚΟ



E. ΛΕΥΚΟ-ΜΠΛΕ



C. ΓΚΡΙ



D. ΜΠΛΕ-ΛΕΥΚΟ



D. ΛΕΥΚΟ-ΓΚΡΙ

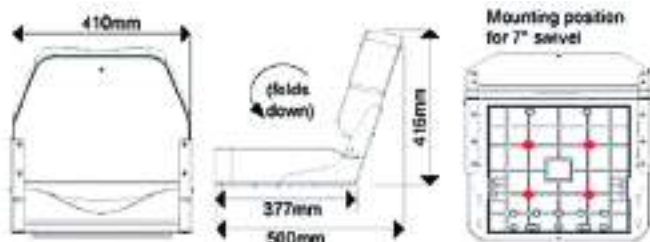

93.095 ΚΑΘΙΣΜΑ DELUXE

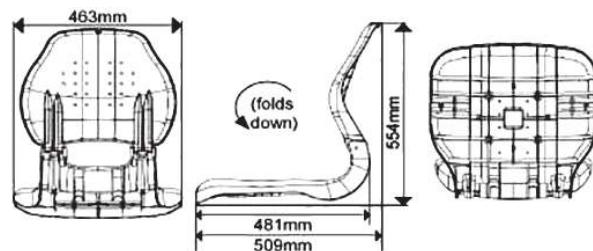

93.096 ΚΑΘΙΣΜΑ SIROCCO



Α.ΓΚΡΙ ΜΑΥΡΟ



Β.ΛΕΥΚΟ ΜΠΛΕ



Γ.ΛΕΥΚΟ ΓΚΡΙ

93.097 ΚΑΘΙΣΜΑ C-SEAT

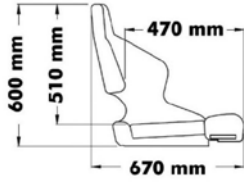
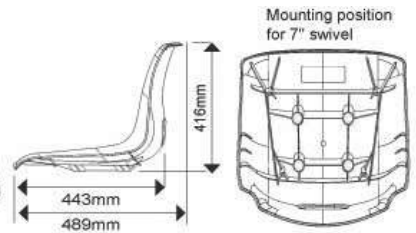
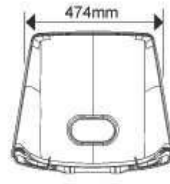

93.100 ΚΑΘΙΣΜΑ ΜΕ FLIP UP Η52 ΜΗΧΑΝΙΣΜΟ

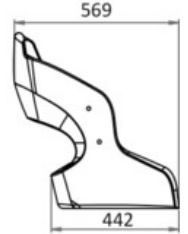
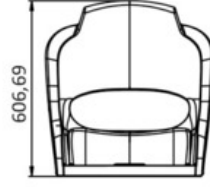

93.098 ΚΑΘΙΣΜΑ ΑΕΡΓΟ ΜΕ ΜΗΧΑΝΙΣΜΟ

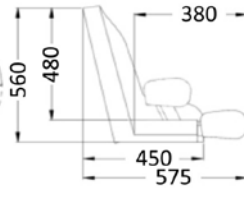
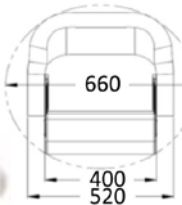

93.099 ΚΑΘΙΣΜΑ ΜΕ FLIP UP Η51 ΜΗΧΑΝΙΣΜΟ

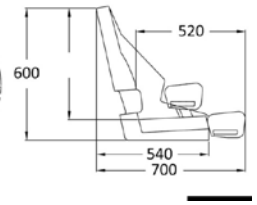
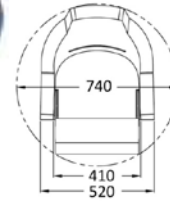

93.101 ΚΑΘΙΣΜΑ ΜΕ FLIP UP RM52 ΣΚΟΥΡΟ ΜΠΛΕ



93.051

ΒΑΣΗ ΚΑΘΙΣΜΑΤΟΣ ΜΕ ΛΕΒΙΕ
31-39cm ΧΩΝΕΥΤΗ



ΒΑΣΗ ΚΑΘΙΣΜΑΤΟΣ
ΜΕ ΛΕΒΙΕ

93.050 34-45cm
93.067 50-63cm



ΒΑΣΗ ΚΑΘΙΣΜΑΤΟΣ
ΑΛΟΥΜΙΝΙΟΥ ΜΕ ΣΦΙΓΚΤΗΡΑ

93.056 Φ60cm 34-51cm
93.052 Φ60cm 45-64cm



ΒΑΣΗ ΚΑΘΙΣΜΑΤΟΣ ΒΤ ΤΗΛΕΣΚΟΠΙΚΗ

ΚΩΔ.	Η mm	ΚΟΛΩΝΑ Ø mm	ΒΑΣΗ Ø mm
93.340	340/470	73/60	228
93.343	430/630	73/60	228



93.055

ΒΑΣΗ ΚΑΘΙΣΜΑΤΩΝ
ΠΕΡΙΣΤΡΕΦΟΜΕΝΗ



ΒΑΣΗ ΚΑΘΙΣΜΑΤΟΣ ΒΤ ΜΕ ΑΜΟΡΤΙΣΕΡ

ΚΩΔ.	Η mm	ΚΟΛΩΝΑ Ø mm	ΒΑΣΗ Ø mm
93.348	460/595	88/73	305
93.349	530/710	88/73	305



ΒΑΣΗ ΚΑΘΙΣΜΑΤΟΣ ΒΤ ΤΗΛΕΣΚΟΠΙΚΗ

ΚΩΔ.	Η mm	ΚΟΛΩΝΑ Ø mm	ΒΑΣΗ Ø mm
93.347	340/470	73/60	228
93.346	430/630	73/60	228



93.059
ΤΡΑΠΕΖΙ ΟΒΑΛ 77x51cm



93.053
ΒΑΣΗ ΤΡΑΠΕΖΙΟΥ 70cm



93.062
ΤΡΑΠΕΖΙ ΠΛΑΣΤΙΚΟ ΜΕ ΟΨΗ ΞΥΛΟΥ
ΜΕ ΠΟΤΗΡΟΘΗΚΕΣ ΙΝΟΧ 76x46



93.060
ΤΡΑΠΕΖΙ ΟΡΘΟΓΩΝΙΟ 81x51cm



93.061
ΒΑΣΗ ΤΡΑΠΕΖΙΟΥ ΛΕΥΚΗ 70 cm



93.066
ΒΑΣΗ ΤΡΑΠΕΖΙΟΥ 70cm
ΜΕ ΕΠΙΠΕΔΗ ΒΑΣΗ



93.064
ΤΡΑΠΕΖΙ ΟΒΑΛ Β.Τ. 76x46cm



93.065
ΒΑΣΗ ΤΡΑΠΕΖΙΟΥ Β.Τ. 68,5cm



98.221
ΤΡΑΠΕΖΙ ΑΛΟΥΜΙΝΙΟΥ 110x60cm



98.222
ΤΡΑΠΕΖΙ ΑΛΟΥΜΙΝΙΟΥ ΟΒΑΛ
95x66cm



98.188
ΚΑΡΕΚΛΑ ΣΚΗΝΟΘΕΤΗ
ΑΛΟΥΜΙΝΙΟΥ
ΕΝΙΣΧΥΜΕΝΗ



93.131
ΚΑΛΑΜΟΘΗΚΗ
ΓΙΑ ΡΕΛΙ
ΕΝΑ ΣΤΗΡΙΓΜΑ



99.213
ΚΑΛΑΜΟΘΗΚΗ
ΓΙΑ ΡΕΛΙ
INOX ΜΕ ΠΛΑΣΤΙΚΟ
ΣΤΗΡΙΓΜΑ



99.211
ΚΑΛΑΜΟΘΗΚΗ
ΒΑΣΕΩΣ
INOX SS316



99.212
ΚΑΛΑΜΟΘΗΚΗ
ΠΛΑΣΤΙΚΗ
ΓΙΑ ΡΕΛΙ



99.244
ΚΑΛΑΜΟΘΗΚΗ
CLICK ΚΙΝΗΤΗ



99.210
ΚΑΛΑΜΟΘΗΚΗ
ΧΩΝΕΥΤΗ INOX 90°



99.219
ΚΑΛΑΜΟΘΗΚΗ
ΧΩΝΕΥΤΗ INOX 30°



99.220
ΚΑΛΑΜΟΘΗΚΗ ΓΙΑ ΡΕΛΙ
INOX SS316 ΟΡΘΙΑ



93.141
ΚΑΛΑΜΟΘΗΚΗ ΓΙΑ ΡΕΛΙ
ΔΥΟ ΣΤΗΡΙΓΜΑΤΑ



99.214
ΚΑΛΑΜΟΘΗΚΗ ΕΠΙΠΕΔΗ
ΜΕ INOX ΣΤΗΡΙΓΜΑΤΑ



99.209
ΚΑΛΑΜΟΘΗΚΗ ΠΛΑΣΤΙΚΗ ΤΡΙΠΛΗ



99.275
ΚΑΛΑΜΟΘΗΚΗ 3ΠΛΗ INOX



99.276
ΚΑΛΑΜΟΘΗΚΗ 4ΠΛΗ INOX



99.278
ΚΑΛΑΜΟΘΗΚΗ
ΠΛΑΣΤΙΚΗ ΜΕ INOX
ΚΑΠΑΚΙ



99.274
ΚΑΛΑΜΟΘΗΚΗ
ΓΙΑ ΡΕΛΙ Φ38-50mm



99.271
ΤΡΑΠΕΖΙ ΨΑΡΕΜΑΤΟΣ
ΓΙΑ ΚΑΛΑΜΟΘΗΚΗ



99.272
ΤΡΑΠΕΖΙ ΨΑΡΕΜΑΤΟΣ
ΓΙΑ ΡΕΛΙ



99.277
ΚΑΛΑΜΟΘΗΚΗ
ΠΛΑΣΤΙΚΗ
ΧΩΝΕΥΤΗ



90.048

ΠΟΤΗΡΟΘΗΚΗ ΙΝΟΧ SS316 ΤΕΤΡΑΓΩΝΗ



93.133

ΠΟΤΗΡΟΘΗΚΗ ΠΛΑΣΤΙΚΗ ΠΕΡΙΣΤΡΕΦΟΜΕΝΗ



96.414

ΠΟΤΗΡΟΘΗΚΗ ΥΦΑΣΜΑΤΙΝΗ ΔΙΠΛΗ COLUMBUS



96.416

ΠΟΤΗΡΟΘΗΚΗ ΥΦΑΣΜΑΤΙΝΗ COLUMBUS



96.421

ΠΟΤΗΡΟΘΗΚΗ ΓΙΑ ΡΕΛΙ ΛΕΥΚΗ



96.434

ΠΟΤΗΡΟΘΗΚΗ Α: ΛΕΥΚΗ Β: ΜΑΥΡΗ



96.412

ΠΟΤΗΡΟΘΗΚΗ ΙΝΟΧ ΕΠΙΚΑΘΗΜΕΝΗ 2 ΘΕΣΕΩΝ



96.415

ΠΟΤΗΡΟΘΗΚΗ ΙΝΟΧ ΕΠΙΚΑΘΗΜΕΝΗ 3 ΘΕΣΕΩΝ



98.147

ΠΟΤΗΡΟΘΗΚΗ ΙΝΟΧ ΟΒΑΛ



96.420

ΠΟΤΗΡΟΘΗΚΗ ΧΩΝΕΥΤΗ ΜΕ ΤΡΥΠΑ ΑΠΟΣΤΡΑΓΓΙΣΗΣ SS316 Α: ΙΝΟΧ Β: ΜΑΥΡΗ



96.427

ΠΟΤΗΡΟΘΗΚΗ ΧΩΝΕΥΤΗ ΙΝΟΧ ΜΙΚΡΗ 70mm Α: ΙΝΟΧ Β: ΜΑΥΡΗ



96.422

ΠΟΤΗΡΟΘΗΚΗ ΧΩΝΕΥΤΗ ΜΕ ΦΩΤΙΣΜΟ LED



96.431

ΘΗΚΗ ΓΙΑ ΑΞΕΣΟΥΑΡ ΠΟΤΗΡΟΘΗΚΗ



96.433

ΘΗΚΗ ΓΙΑ GPS-ΚΙΝΗΤΟ ΤΗΛΕΦΩΝΟ



96.432

ΘΗΚΗ ΓΙΑ ΔΙΑΦΟΡΑ ΑΞΕΣΟΥΑΡ



96.466

ΘΗΚΗ ΜΕ ΔΙΧΤΥ ΠΛΑΣΤΙΚΗ Α: ΛΕΥΚΗ Β: ΜΑΥΡΗ



ΘΗΚΗ ΓΙΑ ΜΑΝΕΛΑ 96.418 ΠΛΑΣΤΙΚΗ 96.422 ΠΛΑΣΤΙΚΗ ΜΕ ΦΩΣ



96.417

ΘΗΚΗ ΜΑΝΕΛΑΣ ΥΦΑΣΜΑΤΙΝΗ COLUMBUS



96.391

ΤΣΑΝΤΑ ΚΡΕΜΑΣΤΗ ΜΙΚΡΗ 31x37cm



96.411

ΤΣΑΝΤΑ ΚΡΕΜΑΣΤΗ ΓΙΑ ΡΕΛΙΑ 37x37cm



ΚΑΛΥΜΜΑ ΣΚΑΦΟΥΣ

ΚΩΔΙΚΟΣ	ΜΗΚΟΣ ΣΚΑΦΟΥΣ	ΜΗΚΟΣ	ΠΛΑΤΟΣ
96.001	3.3 - 4m	4.475mm	2.200mm
96.002	4.0 - 4.5m	5.220mm	2.800mm
96.003	4.5 - 5.4m	5.950mm	3.400mm
96.004	5.4 - 6.4m	7.185mm	3.400mm



ΚΑΛΥΜΜΑ ΣΚΑΦΟΥΣ ΜΕ ΥΦΑΣΜΑ ΑΤΛΑΣ

ΚΩΔΙΚΟΣ	ΜΗΚΟΣ ΣΚΑΦΟΥΣ m	ΜΗΚΟΣ ΚΑΛΥΜΑΤΟΣ mm	ΠΛΑΤΟΣ ΚΑΛΥΜΑΤΟΣ mm	ΠΛΑΤΟΣ ΣΚΑΦΟΥΣ mm
96.051	3.3-4.0	4475	2200	1.8
96.052	4.0-4.5	5220	2800	2.05
96.053	4.5-5.4	5950	3400	2.4
96.054	5.4-6.4	7185	3550	2.6

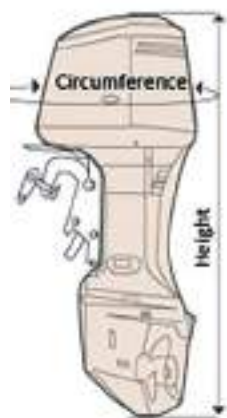

ΚΑΛΥΜΜΑ ΜΗΧΑΝΗΣ ΟΛΟΣΩΜΟ

ΚΩΔΙΚΟΣ	ΜΗΧΑΝΗ hp	ΠΕΡΙΜΕΤΡΟΣ mm	ΥΨΟΣ mm
96.211	ΕΩΣ 3,5	1260	980
96.212	3,5-6	1400	1100
96.213	8,-20	1500	125
96.214	9,9-30	1650	1370
96.215	25-60	1800	1440
96.216	40-100	2000	1700
96.217	70-150	2260	1900
96.218	135-250	2485	1970
96.219	200-300	2540	2100



ΚΑΛΥΜΜΑ ΜΗΧΑΝΗΣ

ΚΩΔΙΚΟΣ	Fits Engine Sizes	ΠΛΑΤΟΣ	ΥΨΟΣ
21.071	Up to 15hp	270mm	320mm
21.072	15hp - 30hp	300mm	400mm
21.073	30hp - 60hp	360mm	490mm
21.074	60hp - 100hp	400mm	530mm
21.075	100hp - 150hp	460mm	580mm
21.076	175hp - 250hp	500mm	600mm



ΚΑΛΥΜΜΑ ΒΙΝΤΖΙΟΥ

ΚΩΔΙΚΟΣ	ΥΨΟΣ mm	ΒΑΣΗ mm
96.271	160	145
96.272	180	150
96.273	200	170
96.274	215	190
96.275	230	200
96.276	250	205
96.277	280	270
96.278	315	290



REAR OPENING FOR ROLL BAR ZIPPER #10

ΚΑΛΥΜΜΑ ΦΟΥΣΚΩΤΟΥ ΜΕ ROLL-BAR

ΚΩΔΙΚΟΣ	ΜΗΚΟΣ ΣΚΑΦΟΥΣ m	ΜΗΚΟΣ ΚΑΛΥΜΑΤΟΣ mm	ΠΛΑΤΟΣ ΚΑΛΥΜΑΤΟΣ mm	ΠΛΑΤΟΣ ΣΚΑΦΟΥΣ mm
96.061	4,7-5,1	6000	3700	2,3
96.062	5,1-5,3	6600	3800	2,3
96.063	5,4-5,6	7000	3900	2,3
96.064	5,7-5,9	7300	4000	2,3
96.065	6,0-6,3	7600	4200	2,3
96.066	6,4-6,7	7900	4300	2,5
96.067	6,8-7,1	8400	4500	2,8
96.068	7,2-7,5	8700	4600	2,8
96.069	7,5-7,8	9100	4700	2,8
96.070	8,0-8,3	9500	4800	2,8

ΚΑΛΥΜΜΑ ΦΟΥΣΚΩΤΟΥ ΤΕΝΤΕΡ

ΚΩΔΙΚΟΣ	ΜΗΚΟΣ ΣΚΑΦΟΥΣ m	ΜΗΚΟΣ ΚΑΛΥΜΑΤΟΣ mm	ΠΛΑΤΟΣ ΚΑΛΥΜΑΤΟΣ mm	ΠΛΑΤΟΣ ΣΚΑΦΟΥΣ mm
96.201	2.3 – 2.6	3.280	2.350	1.5
96.202	2.6 – 2.9	3.580	2.450	1.55
96.203	2.9 – 3.2	3.930	2.550	1.65
96.204	3.2 – 3.6	4.330	2.660	1.75
96.205	3.6 – 3.9	4.650	2.810	1.90
96.206	3.9 – 4.3	5.112	3.000	2.00



ΚΑΛΥΜΜΑ ΦΟΥΣΚΩΤΟΥ ΜΕ T TOP

ΚΩΔΙΚΟΣ	ΜΗΚΟΣ ΣΚΑΦΟΥΣ m	ΜΑΧ ΒΕΑΜ WIDTH m	ΠΛΑΤΟΣ ΚΑΛ/ΤΟΣ mm	ΜΗΚΟΣ ΚΑΛ/ΤΟΣ mm
96.080	6.8 – 7.1	2.8	6600	9100
96.081	7.2 – 7.5	2.8	6600	9500
96.082	7.6 – 7.9	2.8	6600	9800
96.083	8.0 – 8.3	2.8	6600	10200
96.084	8.4 – 8.7	3.1	6700	10600
96.085	8.8 – 9.1	3.1	6100	9700
96.086	9.2 – 9.5	3.2	6300	10200
96.087	9.6 – 9.9	3.2	6300	10600
96.088	10.0 – 10.5	3.2	6300	11100
96.089	10.6 – 11.0	3.2	6300	11600



ΚΑΛΥΜΜΑ ΦΟΥΣΚΩΤΟΥ ΜΕ ΚΕΝΤΡΙΚΗ ΚΟΝΣΟΛΑ ή T/TOP

ΚΑΛΥΜΜΑ ΤΖΕΤ ΣΚΙ ΜΕ ΥΦΑΣΜΑ ΑΤΛΑΣ

ΚΩΔΙΚΟΣ	ΜΗΚΟΣ ΣΚΑΦΟΥΣ m
96.071	2.5-2.9
96.072	2.9-3.4
96.073	3.4-3.7

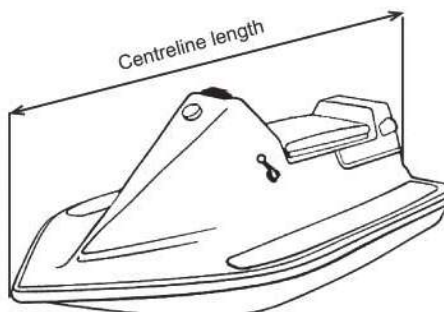



ΚΑΛΥΜΜΑ ΜΗΧΑΝΗΣ ΓΙΑ ΤΑΞΙΔΕΜΑ YAMAHA



ΚΩΔΙΚΟΣ	ΜΟΝΤΕΛΟ ΜΗΧΑΝΗΣ
96.228	XT0 V8 5.6L - F425A
96.229	V6 4.3L - F250, F300, F350
96.221	V8 5.3L - F350
96.222	V6 4.2L - F225, F250, F300
96.223	4 CYL 2.8L - F150, F175, F200
96.224	4 CYL 1.8L - F115, F130
96.225	4 CYL 1.8L - F90C, F100F
96.226	4 CYL 996CC - F50, F60, F70
96.227	3 CYL 747CC - F30, F40

ΚΑΛΥΜΜΑ ΜΗΧΑΝΗΣ ΓΙΑ ΤΑΞΙΔΕΜΑ MERCURY



ΚΩΔΙΚΟΣ	ΜΟΝΤΕΛΟ ΜΗΧΑΝΗΣ
96.230	Verado V12, 7.6L 500-600HP 2021>
96.237	Verado V10, 5.7L 350-400HP
96.236	Verado V8, 4.6L 250-450HP 2018>
96.231	Verado 6CYL 2.6L 200-400HP 2005>
96.238	4stroke V6 3.4L 175HP, 200HP, 225HP
96.232	Verado 4CYL 1.7L 135HP, 150HP, 175HP, 200HP
96.233	4stroke 4CYL 3.0L 135HP, 150HP
96.234	4stroke 4CYL 2.1L 75HP, 80HP, 90HP, 100HP, 115HP
96.235	4stroke 4CYL 995CC 40HP, 50HP, 60HP
96.239	4stroke 3CYL 500CC 25HP, 30HP



ΚΑΛΥΜΜΑ ΜΗΧΑΝΗΣ ΓΙΑ ΤΑΞΙΔΕΜΑ SUZUKI

ΚΩΔΙΚΟΣ	ΜΟΝΤΕΛΟ ΜΗΧΑΝΗΣ
96.241	V6 4.0L - DF250AP, DF300AP
96.242	V6 3.6L - DF200, DF225, DF250
96.243	4 CYL 2.8L - DF150, DF175



17.605
ΓΑΝΤΖΟΣ ΤΗΛΕΣΚΟΠΙΚΟΣ
ΓΚΡΙ 120-210 cm



17.601
ΓΑΝΤΖΟΣ ΤΗΛΕΣΚΟΠΙΚΟΣ
ΜΑΥΡΟΣ 120-210 cm



17.602
ΓΑΝΤΖΟΣ ΤΡΙ-ΤΗΛΕΣΚΟΠΙΚΟΣ
140-360cm



ΓΑΝΤΖΟΣ
ΤΡΙ-ΤΗΛΕΣΚΟΠΙΚΟΣ ΒΤ
17.063 105-240 cm
17.603 120-210 cm



ΓΑΝΤΖΟΣ ΤΗΛΕΣΚΟΠΙΚΟΣ
17.606 ΜΠΛΕ 120-210cm
17.607 ΚΟΚΚΙΝΟΣ 120-210cm



98.121
ΑΝΤΑΛΛΙΚΟ ΑΚΡΟ ΓΑΝΤΖΟΥ



ΣΤΗΡΙΓΜΑΤΑ ΠΛΑΣΤΙΚΑ

- 12.022** Ø 20mm
- 12.023** Ø 25mm
- 12.024** Ø 30mm
- 12.025** Ø 35mm



17.001
ΣΚΑΡΜΟΦΩΛΙΑ ΞΥΛΙΝΗ



17.002
ΣΚΑΡΜΟΦΩΛΙΑ ΠΛΑΣΤΙΚΗ



17.005
ΣΚΑΡΜΟΣ ΞΥΛΙΝΟΣ



17.003
ΣΚΑΡΜΟΣ ΠΛΑΣΤΙΚΟΣ Ø52mm



17.008
ΚΟΥΠΙ ΟΡΤΙΜΙΣΤ



17.609
ΚΟΥΠΙ ΤΗΛΕΣΚΟΠΙΚΟ
LIFERAFT ΠΟΡΤΟΚΑΛΙ



17.012
ΚΟΥΠΙΑ ΚΑΝΟ ΜΑΥΡΟ 230cm
Φ25mm



17.014
ΚΟΥΠΙΑ ΚΑΝΟ ΜΠΛΕ 230cm
Φ28mm



17.010
ΚΟΥΠΙΑ ΚΑΝΟ ΠΟΡΤΟΚΑΛΙ
230cm Φ28mm



ΚΟΥΠΙΑ ΑΛΟΥΜΙΝΙΟΥ ΣΤΑΘΕΡΟ

17.165 1,65m (ΖΕΥΓΟΣ)

17.185 1,85m (ΖΕΥΓΟΣ)

17.205 2,05m (ΖΕΥΓΟΣ)



93.054
ΚΟΥΠΙΑ ΑΛΟΥΜΙΝΙΟΥ
ΤΗΛΕΣΚΟΠΙΚΟ
100-150 cm ΜΕ ΛΑΒΗ



17.015
ΚΟΥΠΙΑ ΚΑΝΟ ΕΝΙΣΧΥΜΕΝΟ
230cm Φ28mm



24.050
ΚΟΥΠΙΑ ΤΗΛΕΣΚΟΠΙΚΟ
110-160cm
ΜΕ ΑΦΑΙΡΟΥΜΕΝΗ ΠΑΛΑΜΗ



24.055
ΚΟΥΠΙΑ ΑΛΟΥΜΙΝΙΟΥ ΜΕ
ΑΠΟΣΠΩΜΕΝΗ ΠΑΛΑΜΗ
140cm



ΚΟΥΠΙΑ ΞΥΛΙΝΟ
ΕΛΑΦΡΟΥ ΤΥΠΟΥ (ΛΕΥΚΟ)

17.181 1,80 m

17.201 2,00 m

17.231 2,30 m

17.251 2,50 m

ΚΟΥΠΙΑ ΞΥΛΙΝΟ
ΒΑΡΕΩΣ ΤΥΠΟΥ (ΘΕΥΑ)

17.180 1,80 m

17.200 2,00 m

17.230 2,30 m

17.250 2,50 m

17.270 2,70 m

17.300 3,00 m



17.016
ΚΟΥΠΙΑ SUP SEAFLO
150-210cm



17.011
ΚΟΥΠΙΑ SUP ΚΑΙ CANOE ΚΑΥΑΚ



17.013
ΚΟΥΠΙΑ SUP 150-210cm



92.006

ΜΑΝΙΚΑ ΠΛΥΣΙΜΑΤΟΣ 25m
ΜΕ ΠΙΣΤΟΛΙ 15 bar 1/2"



NEW

92.005

ΛΑΣΤΙΧΟ ΠΛΥΣΙΜΑΤΟΣ 25m
ΜΕ ΠΙΣΤΟΛΙ 1/2"



NEW

92.031

ΛΑΣΤΙΧΟ RUBBER
ΕΠΕΚΤΙΝΟΜΕΝΟ 2,5-7,5m 1/2"



NEW

ΛΑΣΤΙΧΟ RUBBER ΕΠΕΚΤΙΝΟΜΕΝΟ
92.034 7,5-22,5m 3/4"
92.035 7,5-22,5m 3/4" ΜΕ ΠΙΣΤΟΛΙ



92.007

ΣΩΛΗΝΑΣ ΜΕ ΠΙΣΤΟΛΙ
ΠΛΥΣΙΜΑΤΟΣ
ΣΠΙΡΑΛ 7.5mt



92.001

92.001 ΕΠΕΚΤ/ΝΟ 5-15 mt



98.124

ΣΚΟΥΠΑΚΙ ΜΙΝΙ 12V ΕΠΑΝΑΦ/ΝΟ



98.178

ΣΚΟΥΠΑΚΙ ΜΕ
ΕΙΣΟΔΟ ΝΕΡΟΥ



98.171

ΒΑΣΗ ΤΟΠΟΘΕΤΗΣΗΣ
ΣΦΟΥΓΚΑΡΙΟΥ
ΓΥΑΛΙΣΜΑΤΟΣ



98.187

ΚΑΘΑΡΙΣΤΙΚΗ ΛΕΠΙΔΑ
ΓΙΑ ΤΖΑΜΙΑ



83.047

ΣΦΟΥΓΓΑΡΙ
ΤΡΙΨΙΜΑΤΟΣ ΜΑΛΑΚΟ



83.048

ΣΦΟΥΓΓΑΡΙ
ΤΡΙΨΙΜΑΤΟΣ ΣΚΛΗΡΟ

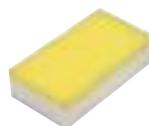

83.041

ΣΦΟΥΓΓΑΡΑΚΙ MAGIC
YACHTICON



83.042

ΣΦΟΥΓΓΑΡΙ ΠΛΥΣΙΜΑΤΟΣ
ΣΚΑΦΟΥΣ



96.470

ΚΟΥΒΑΣ ΣΚΑΦΟΥΣ 8 lt
ΛΑΣΤΙΧΕΝΙΟΣ ΜΕ ΧΕΡΟΥΛΙ



96.464

ΚΟΥΒΑΣ ΣΙΛΙΚΟΝΗΣ
ΠΤΥΣΟΜΕΝΟΣ



96.479

ΚΟΥΒΑΣ ΣΙΛΙΚΟΝΗΣ
ΤΕΤΡΑΓΩΝΟΣ



96.476

ΚΟΥΒΑΣ ΑΝΑΔΙΠΛΟΥΜΕΝΟΣ
ΥΦΑΣΜΑΤΙΝΟΣ



98.186

ΚΑΘΑΡΙΣΤΙΚΟ
ΜΕ ΣΦΟΥΓΓΑΡΙ
ΓΙΑ ΤΖΑΜΙΑ



98.180

ΣΚΟΥΠΑ ΤΟΠΟΘΕΤΗΣΗΣ
ΣΦΟΥΓΓΑΡΙΟΥ
ΚΑΤΑΣΤΡΩΜΑΤΟΣ



98.161

ΣΕΤ ΚΑΘΑΡΙΣΜΟΥ ΜΕ ΓΑΝΤΖΟ
ΤΗΛΕΣΚΟΠΙΚΟ 64-103cm



98.165

ΣΕΤ ΚΑΘΑΡΙΣΜΟΥ
ΜΕ ΔΥΟ ΒΟΥΡΤΣΕΣ ΚΑΙ ΓΑΝΤΖΟ
ΤΗΛΕΣΚΟΠΙΚΟ 64 - 103cm



98.184

ΔΕΡΜΑ ΚΑΘΑΡΙΣΜΟΥ



98.184B

ΔΕΡΜΑ ΚΑΘΑΡΙΣΜΟΥ



98.184C

ΔΕΡΜΑ ΚΑΘΑΡΙΣΜΟΥ



98.184D

ΔΕΡΜΑ ΚΑΘΑΡΙΣΜΟΥ



83.038
83.038 ΑΝΤΑΠΤΟΡΑΣ
ΓΙΑ ΤΡΥΠΑΝΙ



83.039
ΑΝΤΑΠΤΟΡΑΣ ΓΙΑ
ΓΟΥΝΑ ΓΥΑΛΙΣΜΑΤΟΣ



98.190
ΓΑΝΤΙ ΑΠΟ ΜΑΛΛΙ
2τεμ



83.037
ΘΗΚΗ ΣΦΟΥΓΓΑΡΙΟΥ
ΧΕΙΡΟΚΙΝΗΤΗΣ ΕΡΓΑΣΙΑΣ



83.034
ΓΟΥΝΑ ΓΥΑΛΙΣΜΑΤΟΣ
ΜΑΛΑΚΗ



83.035
ΓΟΥΝΑ ΓΥΑΛΙΣΜΑΤΟΣ
ΧΟΝΤΡΗ 2ΠΛΗΣ ΟΨΗΣ



83.031
ΣΦΟΥΓΓΑΡΙ ΓΥΑΛΙΣΜΑΤΟΣ
ΣΚΛΗΡΟ 2τεμ



83.032
ΣΦΟΥΓΓΑΡΙ ΓΥΑΛΙΣΜΑΤΟΣ
ΜΕΣΑΙΑΣ ΣΚΛΗΡΟΤΗΤΑΣ 2τεμ



98.197
ΓΑΝΤΙ ΜΙΚΡΟΙΝΩΝ



83.036
ΠΑΝΑΚΙ ΜΕ ΜΙΚΡΟΙΝΕΣ
2τεμ.



98.191
ΧΑΡΤΙ ΚΑΘΑΡΙΣΜΟΥ



83.033
ΣΦΟΥΓΓΑΡΙ ΓΥΑΛΙΣΜΑΤΟΣ
ΜΑΛΑΚΟ 2τεμ



98.199
ΑΠΟΧΗ ΤΗΛΕΣΚΟΠΙΚΗ
-ΣΠΑΣΤΗ



98.198
ΑΠΟΧΗ ΓΙΑ ΚΟΝΤΑΡΙ



91.100A
ΤΕΑΚ EVA FOAM
ΜΕ ORIGINAL 3M ΚΑΦΕ

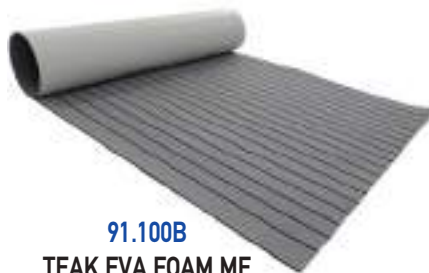

91.100B
ΤΕΑΚ EVA FOAM ΜΕ
ORIGINAL 3M ΓΚΡΙ



EVA FOAM

Μέγεθος 120 x 240 cm
Πάχος 6 mm
Σκληρότητα Σκληρότητα: 50~55 μοίρες
Πυκνότητα Πυκνότητα: 130~140 kg/m³
Υλικό Αφρός Closed Cell Marine EVA
Συγκολλητικός 3M / Ισχυρή κόλλα
Ανθεκτικό στην υπεριώδη ακτινοβολία 3000 ώρες



98.081

ΣΚΟΥΠΑ ΞΥΛΙΝΗ 6" ΜΑΛΑΚΗ ΚΙΤΡΙΝΗ



98.083

ΣΚΟΥΠΑ ΞΥΛΙΝΗ 8" ΚΙΤΡΙΝΗ ΜΑΛΑΚΗ



98.084

ΣΚΟΥΠΑ ΞΥΛΙΝΗ 8" ΜΠΛΕ ΜΕΤΡΙΑ



98.182

ΣΚΟΥΠΑ ΞΥΛΙΝΗ ΜΑΛΑΚΗ 10"



98.183

ΣΚΟΥΠΑ ΞΥΛΙΝΗ ΣΚΛΗΡΗ 10"



98.196

ΣΚΟΥΠΑ ΛΕΥΚΗ ΣΚΛΗΡΗ 10"



98.176

ΣΚΟΥΠΑ ΜΠΛΕ
ΜΕΣΑΙΑ ΣΚΛΗΡΟΤΗΤΑ 10"



98.177

ΣΚΟΥΠΑ ΚΙΤΡΙΝΗ
ΜΑΛΑΚΗ ΣΚΛΗΡΟΤΗΤΑ 10"



98.185

ΣΦΟΥΓΓΑΡΙΣΤΡΑ



98.310

ΣΚΟΥΠΑ 5-ΓΩΝΙΕΣ ΤΗΛΕΣΚΟΠΙΚΗ
117-180cm



98.120

ΓΑΝΤΖΟΣ ΓΙΑ
ΚΟΝΤΑΡΙ ΣΚΟΥΠΑΣ



98.175

ΚΟΝΤΑΡΙ ΣΚΟΥΠΑΣ
153cm

98.174

ΚΟΝΤΑΡΙ ΣΚΟΥΠΑΣ
ΤΗΛΕΣΚΟΠΙΚΟ
90-160cm



83.004
ΚΑΘΑΡΙΣΤΙΚΟ ΙΝΟΧ
ΕΠΙΦΑΝΕΙΩΝ



83.012
ΚΑΘΑΡΙΣΤΙΚΟ
ΚΙΤΡΙΝΩΠΟΥ GELCOAT



83.013
ΚΑΘΑΡΙΣΤΙΚΟ ΓΙΑ
ΔΕΞΑΜΕΝΗ ΝΕΡΟΥ



83.018
ΚΑΘΑΡΙΣΤΙΚΟ
ΔΕΞΑΜΕΝΗΣ ΝΕΡΟΥ
ΤΑΜΠΛΕΤΕΣ για 2000lt



94.061
ΣΑΜΠΟΥΑΝ Β CARE
ΒΙΟΔΙΑΣΠΩΜΕΝΟ



83.008
ΚΑΘΑΡΙΣΤΙΚΟ ΠΟΛΛΑΠΛΩΝ
ΧΡΗΣΕΩΝ



83.009
ΚΑΘΑΡΙΣΤΙΚΟ ΜΠΑΛΟΝΙΩΝ
(PVC-HYRALON)



83.011
ΚΑΘΑΡΙΣΤΙΚΟ ΣΚΟΥΡΙΑΣ



83.015
ΑΠΟΣΥΝΘΕΤΙΚΟ
ΛΥΜΑΤΩΝ 1 lt



83.007
GEL COAT ΜΟΝΟ ΣΥΣΤΑΤΙΚΟ



83.006
GEL COAT ΔΥΟ ΣΥΣΤΑΤΙΚΩΝ



83.020
ΑΛΟΙΦΗ ΛΕΙΑΝΣΗΣ ΠΟΛΥ ΧΟΝΤΡΗ P600 5kg



83.021
ΑΛΟΙΦΗ ΛΕΙΑΝΣΗΣ
ΧΟΝΤΡΗ P1000 1kg



83.022
ΑΛΟΙΦΗ ΛΕΙΑΝΣΗΣ
ΜΕΣΑΙΑΣ ΥΦΗΣ P1500 1kg



83.023
ΑΛΟΙΦΗ ΛΕΙΑΝΣΗΣ
ΦΙΝΙΡΙΣΜΑΤΟΣ P2500 1kg



83.024
ΑΛΟΙΦΗ ΠΡΟΣΤΑΤΕΥΤΙΚΗ
ΜΕ ΚΕΡΙ 1kg



83.001

ΚΑΘΑΡΙΣΤΙΚΟ ΣΑΜΠΟΥΑΝ ΣΚΑΦΟΥΣ
ΜΕ ΧΑΜΗΛΟ ΑΦΡΟ 1Lit



83.002

ΚΑΘΑΡΙΣΤΙΚΟ ΛΕΚΕΔΩΝ
ΑΠΟ ΤΗΝ ΕΠΙΦΑΝΕΙΑ ΤΟΥ ΤΕΑΚ 1Lit



83.003

ΚΑΘΑΡΙΣΤΙΚΟ ΣΕΝΤΙΝΩΝ
5Lit



83.014

ΚΑΘΑΡΙΣΤΙΚΟ ΑΝΑΝΕΩΣΗΣ
ΤΟΥ ΤΕΑΚ II 1 lt



83.010

ΠΡΟΣΤΑΤΕΥΤΙΚΟ ΛΑΔΙ
ΓΙΑ ΤΕΑΚ 1Lit



TEAK WONDER DRESSING &
SEALER

40.086 1 LT 40.083 4 LT



40.080

TEAK WONDER BRIGHTENER 4 LT



40.081

TEAK WONDER TEAK CLEANER 4 LT



40.082

TEAK WONDER+COMBO
1LT+CLEANER+1LT BRIGHTENER



83.103
02 ΚΑΘΑΡΙΣΤΙΚΟ
ΣΚΑΦΟΥΣ ΓΙΑ
ΚΙΤΡΙΝΙΛΕΣ & ΙΧΝΗ
ΣΚΟΥΡΙΑΣ



83.104
03 ΚΑΘΑΡΙΣΤΙΚΟ
ΜΠΑΛΟΝΙΩΝ
& ΠΑΡΑΒΛΗΜΑΤΩΝ
750ML



06 ΣΑΜΠΟΥΑΝ ΜΕ
ΝΑΝΟΚΕΡΙ ΣΟΑΤΙΝΙΟΥΜ
83.101 1 LT
83.102 5 LT



83.105
07 ΚΑΘΑΡΙΣΤΙΚΟ
ΦΟΥΣΚΩΤΩΝ &
ΗΜΙΑΚΑΜΠΤΩΝ
ΣΚΑΦΩΝ 750ML



09 ΕΠΑΓΓΕΛΜΑΤΙΚΟ
ΚΑΘΑΡΙΣΤΙΚΟ
ΓΕΝΙΚΗΣ ΧΡΗΣΗΣ
83.107 1 LT
83.106 5 LT



83.108
P11 ΣΤΙΛΒΩΤΙΚΟ
ΓΙΑ ΣΥΝΤΗΡΗΣΗ &
ΦΙΝΙΡΙΣΜΑ PRO-ULTRA
FINE 1LT



83.109
P12 ΣΤΙΛΒΩΤΙΚΟ ΓΙΑ
ΕΛΑΦΡΑ ΦΘΑΡΜΕΝΗ
ΜΠΟΓΙΑ & GELCOAT
PRO-MEDIUM 1LT



83.110
P13 POLISH
PRO-CUT



83.111
T17 ΚΑΘΑΡΙΖΕΙ
& ΑΠΟΚΑΘΙΣΤΑ
ΤΟ ΞΥΛΟ TEAK 1LT



83.112
14 ΑΝΤΙΣΚΩΡΙΑΚΟ
ΤΖΕΛ 500ML



83.113
T18 ΛΕΥΚΑΝΤΙΚΗ
ΦΟΡΜΟΥΛΑ-
ΑΝΑΞΘΡΟΓΟΝΗΤΙΚΟ
ΞΥΛΟΥ TEAK 1LT



83.114
CNX50 ΕΝΙΣΧΥΜΕΝΟ
ΜΟΡΙΑΚΟ ΚΕΡΑΜΙΚΟ
ΚΕΡΙ 750ML



83.115
CNX 1000
ΠΡΟΣΤΑΤΕΥΤΙΚΟ
ΦΙΛΜ ΒΑΣΙΣΜΕΝΟ ΣΕ
ΜΟΡΙΑΚΟ ΚΕΡΑΜΙΚΟ



83.116
21 ΚΑΘΑΡΙΣΤΙΚΟ
ΥΦΑΣΜΑΤΩΝ &
ΛΕΚΕΔΩΝ 750ML



83.117
CNX20 ΣΑΜΠΟΥΑΝ
ΠΡΟΣΤΑΣΙΑΣ
ΚΕΡΑΜΙΚΟΥ 1LT



83.118
CNX20 ΣΑΜΠΟΥΑΝ
ΠΡΟΣΤΑΣΙΑΣ
ΚΕΡΑΜΙΚΟΥ 1LT



83.120
10 EXPRESS
WAX 1LT



83.122
04 ΑΦΑΙΡΕΤΙΚΟ
ΜΟΥΧΛΑΣ ΣΠΡΕΥ
750ML



83.123
16 ΚΑΘΑΡΙΣΤΙΚΟ
ΣΕΝΤΙΝΑΣ 750ML



83.124
27 ΚΑΘΑΡΙΣΤΙΚΟ
ΑΦΑΙΡΕΣΗΣ ΑΛΑΤΙΟΥ 1L



83.125
23 ΓΥΑΛΙΣΤΙΚΟ
ΜΕΤΑΛΛΟΥ 250ML



83.126
25 ΥΔΡΟΑΠΩΘΗΤΙΚΟ
ΥΓΡΟ ΓΙΑ ΤΑ ΤΖΑΜΙΑ
750ML



83.127
13.5 COMPOUND
PRO MAX 1L

ΚΑΘΑΡΙΣΤΙΚΑ-ΛΙΠΑΝΤΙΚΑ



40.091
ΣΠΡΕΥ ΡΤΦΕ 400ML



40.092
ΣΠΡΕΥ ΛΙΠΑΝΤΙΚΟ
ΜΕΤΑΛΛΩΝ 200ML



40.093
ΣΠΡΕΥ ΛΕΥΚΟ ΓΡΑΣΣΟ
400 ML



40.094
ΣΠΡΕΥ ΒΑΣΕΛΙΝΗΣ
400 ML



40.095
ΣΠΡΕΥ ΚΑΘΑΡΙΣΜΟΥ
ΑΝΟΣΕΙΔΩΤΩΝ
ΜΕΤΑΛΛΩΝ 400ML



40.096
ΣΠΡΕΥ ΣΙΛΙΚΟΝΗΣ
ΛΙΠΑΝΤΙΚΟ 400ML



40.085
ΑΦΑΙΡΕΤΙΚΟ ΛΕΚΕΔΩΝ
POLITEAK 400ML



40.084
ΑΦΑΙΡΕΤΙΚΟ ΛΕΚΕΔΩΝ
TEAK WONDER 250ML



41.011
ΛΙΠΑΝΤΙΚΟ
ΑΝΤΙΣΚΩΡΙΑΚΟ
150ML



41.012
ΛΙΠΑΝΤΙΚΟ
ΑΝΤΙΣΚΩΡΙΑΚΟ
300ML

- ΣΥΣΤΑΤΙΚΑ ΒΙΟΛΟΓΙΚΗΣ ΠΡΟΕΛΕΥΣΗΣ
- 8 ΣΕ 1 ΧΡΗΣΕΙΣ: ΧΑΛΑΡΩΝΕΙ, ΠΡΟΣΤΑΤΕΥΕΙ, ΛΙΠΑΙΝΕΙ, ΣΥΝΤΗΡΕΙ, ΣΤΑΜΑΤΑΕΙ ΤΡΙΞΙΜΑΤΑ, ΚΑΘΑΡΙΖΕΙ, ΑΠΟΜΑΚΡΥΝΕΙ ΤΗΝ ΥΓΡΑΣΙΑ, ΕΠΑΝΑΦΕΡΕΙ ΣΕ ΛΕΙΤΟΥΡΓΙΑ ΗΛΕΚΤΡΙΚΕΣ ΕΠΑΦΕΣ
- ΚΕΦΑΛΗ ΔΙΠΛΗΣ ΧΡΗΣΗΣ ΨΕΚΑΣΜΟΣ 360°
- ΛΙΓΟΤΕΡΑ ΣΗΜΑΤΑ ΕΠΙΚΙΝΔΥΝΟΤΗΤΑΣ
- ΟΜΟΙΟΓΕΝΕΙΑ ΥΛΙΚΟΥ



41.002
WD-40 200ML



41.006
WD-40 400ML



41.001
WD-40 100ML



41.003
WD-40 SMART
STRAW 250ML



41.004
WD-40 SMART
STRAW 450ML



41.005
WD-40 SPECIALIST
SILICONE SPRAY
400ML



41.007
WD-40 SPECIALIST
CONTACT CLEANER
SPRAY 400ML



41.008
WD-40 SPECIALIST
WHITE LITHIUM
GREASE SPRAY 400ML



41.009
WD-40 SPECIALIST
FAST ACTING
DEGREASER 500ML



SIKAFLEX 591 70ML
83.043 ΜΑΥΡΟ
83.046 ΛΕΥΚΟ



83.044
SIKAFLEX 291I
ΜΑΥΡΟ 300 ML



83.045
SIKAFLEX 291I
ΛΕΥΚΟ 300 ML



SITOL MARINE

ΚΩΔΙΚΟΣ	ΧΡΩΜΑ	ΧΩΡΗΤ/ΤΑ ml
83.051A	ΛΕΥΚΟ	80
83.051B	ΜΑΥΡΟ	80
83.052A	ΛΕΥΚΟ	290
83.052B	ΜΑΥΡΟ	290
83.053A	ΛΕΥΚΟ	600
83.053B	ΜΑΥΡΟ	600

- UV-, weather-, chemical- and saltwater-resistant
- Adheres to wet and immersed substrates
- Free of solvents and isocyanates. It does not require training according to Annex XVII of Regulation (EC) 1907/2006
- Compatible with marine industry materials on deck/main deck and below deck

NEW

SITOL® DECK CAULKING



ΚΩΔΙΚΟΣ	ΧΡΩΜΑ	ΧΩΡΗΤ/ΤΑ ml
83.061B	ΜΑΥΡΟ	290
83.062B	ΜΑΥΡΟ	600

- Sandable after hardening
- Excellent UV and ageing resistance
- High chemical resistance
- Excellent workability

NEW

SITOL MED



ΚΩΔΙΚΟΣ	ΧΡΩΜΑ	ΧΩΡΗΤ/ΤΑ ml
83.056A	ΛΕΥΚΟ	290
83.056B	ΜΑΥΡΟ	290
83.057A	ΛΕΥΚΟ	600
83.057B	ΜΑΥΡΟ	600

- Resistant to UV, weathering, chemicals and salt water
- Solvent and isocyanate free: NOT requiring training according to Annex XVII of Regulation (EC) 1907/2006
- Compatible with marine industry materials on deck/bridges and under decks
- Permanently elastic within a temperature range of -40 °C to +100 °C

NEW

83.065 SITOL® PRIMER DECK CAULKING 0.5LT



- Protection of teak wood
- Improving adhesion on wood substrates
- Pre-treatment of teak deck components
- Pre-treatment of substrates such as wood, GRP, epoxy primers, mineral substrates
- Avoids staining of absorbent substrates
- Ideal for immersion joints
- Compatible with wrinkled and Teflon-coated

ΥΦΑΛΟΧΡΩΜΑΤΑ, ΑΣΤΑΡΙΑ



ΥΦΑΛΟΧΡΩΜΑ ΠΡΟΠΕΛΩΝ 0,25LT
40.071A ΛΕΥΚΟ
40.071B ΜΑΥΡΟ



ΥΦΑΛΟΧΡΩΜΑ ΠΡΟΠΕΛΩΝ 0,5LT
40.074A ΛΕΥΚΟ
40.074B ΜΑΥΡΟ



40.073
ΑΣΤΑΡΙΑ ΑΛΟΥΜΙΝΙΟΥ
0,25LT VELOX



40.075
ΑΣΤΑΡΙΑ ΑΛΟΥΜΙΝΙΟΥ
0,5LT VELOX



Classic

Ταχύτητα: Έως 20 κόμβους
Αραιώση: Έτοιμο προς χρήση. Εφ' όσον είναι απαραίτητο αραιώνουμε έως 5% με Eumaria Thinner 200
Τρόπος Εφαρμογής: Με ρολό, πινέλο ή πιστόλι airless
Απόδοση: 8 - 12 m²/L

ΚΩΔΙΚΟΣ	750mL	ΚΩΔΙΚΟΣ	2,5Lt	ΚΩΔΙΚΟΣ	20Lt
40.001A	ΚΟΚΚΙΝΟ	40.002A	ΚΟΚΚΙΝΟ	40.003A	ΚΟΚΚΙΝΟ
40.001B	ΜΑΥΡΟ	40.002B	ΜΑΥΡΟ	40.003B	ΜΑΥΡΟ
40.001C	ΜΠΛΕ	40.002C	ΜΠΛΕ	40.003C	ΜΠΛΕ



Ultra Multi

Ταχύτητα: Έως 32 κόμβους
Αραιώση: Έτοιμο προς χρήση. Εφ' όσον είναι απαραίτητο αραιώνουμε έως 5% με Eumaria Thinner 200
Τρόπος Εφαρμογής: Με ρολό, πινέλο ή πιστόλι airless
Απόδοση: 8 - 10 m²/L

ΚΩΔΙΚΟΣ	750mL	ΚΩΔΙΚΟΣ	2,5Lt	ΚΩΔΙΚΟΣ	20Lt
40.015A	ΛΕΥΚΟ	40.016A	ΛΕΥΚΟ	40.017A	ΛΕΥΚΟ
40.015B	ΜΑΥΡΟ	40.016B	ΜΑΥΡΟ	40.017B	ΜΑΥΡΟ
40.015C	ΓΚΡΙ	40.016C	ΓΚΡΙ	40.017C	ΓΚΡΙ
40.015D	ΓΑΛΑΖΙΟ	40.016D	ΓΑΛΑΖΙΟ	40.017D	ΓΑΛΑΖΙΟ



Ultra

Ταχύτητα: Έως 32 κόμβους
Αραιώση: Έτοιμο προς χρήση. Εφ' όσον είναι απαραίτητο αραιώνουμε έως 5% με Eumaria Thinner 200
Τρόπος Εφαρμογής: Με ρολό, πινέλο ή πιστόλι airless
Απόδοση: 8 - 10 m²/L

ΚΩΔΙΚΟΣ	750mL	ΚΩΔΙΚΟΣ	2,5Lt	ΚΩΔΙΚΟΣ	20Lt
40.011A	ΚΟΚΚΙΝΟ	40.012A	ΚΟΚΚΙΝΟ	40.013A	ΚΟΚΚΙΝΟ
40.011B	ΜΑΥΡΟ	40.012B	ΜΑΥΡΟ	40.013B	ΜΑΥΡΟ
40.011C	ΜΠΛΕ	40.012C	ΜΠΛΕ	40.013C	ΜΠΛΕ



Paint Remover

Εξαιρετικά δραστικό αφαιρετικό χρωμάτων και βερνικιών νέας τεχνολογίας χωρίς διχλωρομεθάνιο.

ΚΩΔΙΚΟΣ	1Lt	ΚΩΔΙΚΟΣ	2,5Lt
40.045		40.046	



Βινυλικό Αστάρι

Αραιώση: Έτοιμο προς χρήση. Εφ' όσον είναι απαραίτητο αραιώνουμε έως 10% με Eumaria Thinner 200
Τρόπος Εφαρμογής: Με ρολό, πινέλο ή πιστόλι airless
Απόδοση: 8 - 12 m²/L

ΚΩΔΙΚΟΣ	1Lt	ΚΩΔΙΚΟΣ	2,5Lt	ΚΩΔΙΚΟΣ	20Lt
40.031	ΑΣΗΜΙ	40.032	ΑΣΗΜΙ	40.033	ΑΣΗΜΙ



Εποξειδικό Αστάρι

Αραιώση: Έτοιμο προς χρήση. Εφ' όσον είναι απαραίτητο αραιώνουμε έως 10% με Eumaria Thinner 200
Τρόπος Εφαρμογής: Με ρολό, πινέλο, πιστόλι αέρος ή airless
Απόδοση: 8 - 12 m²/L

ΚΩΔΙΚΟΣ	750mL	ΚΩΔΙΚΟΣ	3,5Lt	ΚΩΔΙΚΟΣ	20Lt
40.035A	ΛΕΥΚΟ	40.036A	ΛΕΥΚΟ	40.037A	ΛΕΥΚΟ
40.035B	ΓΚΡΙ	40.036B	ΓΚΡΙ	40.037B	ΓΚΡΙ



Διαλυτικό Υφαλοχρωμάτων

Διαλυτικό ιδανικό για την αραιώση των υφαλοχρωμάτων EUMARIA και των ασταριών ενός συστατικού. Κατάλληλο και για τον καθαρισμό των εργαλείων.

ΚΩΔΙΚΟΣ	1Lt	ΚΩΔΙΚΟΣ	5Lt
40.041		40.042	



Διαλυτικό Εποξειδικών Ασταριών

Διαλυτικό ιδανικό για την αραιώση εποξειδικών ασταριών και εποξειδικών χρωματων δύο συστατικών. Κατάλληλο και για τον καθαρισμό των εργαλείων.

ΚΩΔΙΚΟΣ	1Lt	ΚΩΔΙΚΟΣ	5Lt
40.061		40.062	



ΣΩΣΙΒΙΟ ΦΟΥΣΚΩΤΟ ISO 150N
ΑΥΤΟ/MANUAL ΜΕ ΚΡΙΚΟ ΠΡΟΣΔΕΣΗΣ

- 21.015 ΚΟΚΚΙΝΟ 40+kg
- 21.016 ΜΠΛΕ 40+kg
- 21.175 ΠΑΙΔΙΚΟ ΚΟΚΚΙΝΟ



ΣΩΣΙΒΙΟ SOLAS MSC200(80) LSA CODE

- 99.252 ΣΩΣΙΒΙΟ ΦΟΥΣΚΩΤΟ ΑΥΤΟ 150N
- 99.253 ΣΩΣΙΒΙΟ ΦΟΥΣΚΩΤΟ ΑΥΤΟ 275N



99.254
ΣΩΣΙΒΙΟ 150N CE
ΑΥΤΟΜΑΤΟ
Α ΚΟΚΚΙΝΟ
Β ΜΠΛΕ
C ΜΑΥΡΟ



99.255
ΣΩΣΙΒΙΟ ΦΟΥΣΚΩΤΟ
150N CE ΜΕ ΚΡΙΚΟ
ΑΣΦΑΛΕΙΑΣ



98.153

ΜΗΧΑΝΙΣΜΟΣ ΑΥΤ.ΣΩΣΙΒΙΟΥ UML



98.155 - ΚΙΤ ΜΗΧΑΝΙΣΜΟΥ UML+
ΜΠΟΥΚΑΛΑ 33gr

98.146 - ΜΠΟΥΚΑΛΑ ΑΥΤΟΜΑΤΟΥ
ΣΩΣΙΒΙΟΥ 33 gr



ΣΩΣΙΒΙΟ ΣΚΙ ΜΑΥΡΟ
4 ΙΜΑΝΤΕΣ ISO 50N

- 21.202 30-50 kg
- 21.203 50-70 kg
- 21.204 70-90 kg
- 21.205 90+ kg



98.154

ΜΗΧΑΝΙΣΜΟΣ ΑΥΤ.ΣΩΣΙΒΙΟΥ
HALKEY ROBERTS



ΣΩΣΙΒΙΟ ΣΚΙ
ΚΟΚΚΙΝΟ/ΛΕΥΚΟ
4 ΙΜΑΝΤΕΣ ISO 50N

- 21.193 30-50 kg
- 21.194 50-70 kg
- 21.195 70-90 kg
- 21.196 90+kg



ΣΩΣΙΒΙΟ ΣΚΙ
NEOPREN

- 21.172A 30-50 kg
- 21.172B 50-70 kg
- 21.172C 70-90 kg
- 21.172D 90+kg



**ΣΩΣΙΒΙΟ ΑΓΩΝΙΣΤΙΚΟ
ΚΟΚΚΙΝΟ-ΓΚΡΙ
ISO 50N**

21.160	30-50 kg
21.161	50-70 kg
21.162	70-90 kg
21.163	90+ kg



**ΣΩΣΙΒΙΟ ΑΓΩΝΙΣΤΙΚΟ
ΠΟΡΤΟΚΑΛΙ-ΛΕΥΚΟ
ISO 50N**

21.176	30-50 kg
21.177	50-70 kg
21.178	70-90 kg
21.179	90+ kg



**ΣΩΣΙΒΙΟ ΑΓΩΝΙΣΤΙΚΟ
ΜΑΥΡΟ ISO 50N**

21.168	30-50 kg
21.169	50-70 kg
21.170	70-90 kg
21.171	90+ kg



ΣΩΣΙΒΙΟ ΓΙΛΕΚΟ SF

21.241	30-50kg
21.242	50-70kg
21.243	70-90kg
21.244	90kg+



ΣΩΣΙΒΙΟ ΓΙΛΕΚΟ SF

21.251	30-50kg
21.252	50-70 kg
21.253	70-90kg
21.254	90kg+



**ΣΩΣΙΒΙΟ ACTIVE DOUBLE
FACE ISO 50N**

21.211	30-50kg
21.212	50-70kg
21.213	70-90kg
21.214	90+ kg



ΣΩΣΙΒΙΟ SOLAS MSC200(80) LSA CODE

21.198	ΠΑΙΔΙΚΟ	15/43KG	109N
21.182	ΕΝΗΛΙΚΩΝ	+43 KG	190N



**21.021
ΣΦΥΡΙΧΤΡΑ ΣΩΣΙΒΙΩΝ**



ΣΩΣΙΒΙΟ ΖΑΚΕΤΑ

21.041	NO 1	20-30
21.042	NO 2	30-50
21.043	NO 3	50-70
21.044	NO 4	70-90
21.045	NO 5	90+

SOLAS '83



21.001 - ΣΩΣΙΒΙΟ ΕΝΗΛΙΚΩΝ
21.002 - ΣΩΣΙΒΙΟ ΠΑΙΔΙΚΟ

SOLAS '74



21.011 - ΣΩΣΙΒΙΟ ΕΓΚΕΚΡΙΜΕΝΟ ΕΝΗΛΙΚΩΝ
21.012 - ΣΩΣΙΒΙΟ ΕΓΚΕΚΡΙΜΕΝΟ ΠΑΙΔΙΚΟ



21.019 ΣΩΣΙΒΙΟ ΕΝΗΛΙΚΩΝ 100N ISO12402-4
21.020 ΣΩΣΙΒΙΟ ΠΑΙΔΙΚΟ 100N ISO12402-4



ΣΩΣΙΒΙΟ ΠΑΙΔΙΚΟ
ISO 100N

21.154 5-10 kg FISH
21.156 10-20 kg FISH
21.192 20-30 kg FISH



ΣΩΣΙΒΙΟ ΠΑΙΔΙΚΟ
SAIL MARINE

21.051 NO1 5-10 kg
21.052 NO2 10-20 kg
21.053 NO3 20-30 kg



ΣΩΣΙΒΙΟ ΠΟΡΤΟΚΑΛΙ
ΠΑΙΔΙΚΟ ISO 100N

21.190 5-10 kg
21.188 10-20 kg
21.057 20-30 kg



ΣΩΣΙΒΙΟ ΠΟΡΤΟΚΑΛΙ
ISO 100N

21.221 30-40 kg
21.222 40-60 kg
21.223 60-70 kg
21.224 70-90 kg
21.225 90+ kg



ΣΩΣΙΒΙΟ ΣΚΥΛΟΥ
21.230 ΕΩΣ 15kg
21.231 ΕΩΣ 40kg



ΤΣΑΝΤΑ ΣΩΣΤΙΚΩΝ ΣΩΣΙΒΙΩΝ
21.199 - 4 (σε 2 χρώμ.)
21.200 - 6 (σε 2 χρώμ.)



ΠΛΕΥΣΤΙΚΗ ΣΥΣΚΕΥΗ

20.953 3 ΑΤΟΜΩΝ ΕΓΚΕΚΡΙΜΕΝΗ
20.954 4 ΑΤΟΜΩΝ ΕΓΚΕΚΡΙΜΕΝΗ



ΣΧΕΔΙΑ ΠΟΛΥΕΣΤΕΡΙΚΗ

20.804 4 ΑΤΟΜΩΝ
20.805 6 ΑΤΟΜΩΝ
20.808 8 ΑΤΟΜΩΝ
20.812 12 ΑΤΟΜΩΝ
20.820 20 ΑΤΟΜΩΝ



ΣΩΣΙΒΙΟ ΠΕΤΑΛΟ

20.498 ΠΟΡΤΟΚΑΛΙ

20.499 ΚΙΤΡΙΝΟ

20.496 ΚΑΛΥΜΑ ΑΝΤ/ΚΟ ΠΟΡΤΟΚΑΛΙ

20.497 ΚΑΛΥΜΑ ΑΝΤ/ΚΟ ΚΙΤΡΙΝΟ



20.495

ΠΕΤΑΛΟ ΣΩΣΙΒΙΟ ΛΕΥΚΟ



20.503

**ΘΗΚΗ ΠΕΤΑΛΟΥ ΓΙΑ
ΤΟΠΟΘΕΤΗΣΗ ΣΕ ΡΕΛΙΑ**



20.502

ΒΑΣΗ ΙΝΟΧ ΠΕΤΑΛΟΥ



20.506

ΒΑΣΗ ΙΝΟΧ ΚΥΚΛΙΚΟΥ



20.493

ΣΧΟΙΝΙ ΔΙΑΣΩΣΗΣ 28m



20.494

**ΒΑΣΗ ΙΝΟΧ ΓΙΑ ΣΧΟΙΝΙ
ΔΙΑΣΩΣΗΣ**



24.062

ΣΩΣΙΒΙΟ ΝΑΥΑΓΟΣΩΣΤΩΝ ΒΑΥWATCH



10.119

ΣΥΣΤΗΜΑ ΔΙΑΣΩΣΗΣ



21.028

ΠΥΡΙΜΑΧΗ ΚΟΥΒΕΡΤΑ



21.030

ΤΣΕΚΟΥΡΙ ΠΥΡΟΣΒΕΣΤΗ



ΣΚΑΛΑ ΕΠΙΒΙΒΑΣΗΣ

21.032 5 ΜΕΤΡΩΝ

21.033 10 ΜΕΤΡΩΝ



20.614
ΘΗΚΗ ΚΥΚΛΙΚΟΥ
ΠΛΑΣΤΙΚΗ



20.615
ΒΑΣΗ ΣΤΗΡΙΞΗΣ
ΘΗΚΗΣ ΚΥΚΛΙΚΟΥ



20.601
ΚΥΚΛΙΚΟ ΣΩΣΙΒΙΟ
Φ45cm



20.602
ΚΥΚΛΙΚΟ ΣΩΣΙΒΙΟ
Φ60cm



20.610 - ΣΧΟΙΝΙ ΚΥΚΛΙΚΟΥ
ΕΠΙΠΛΕΟΝ 6mm 30m

20.611 - ΣΧΟΙΝΙ ΚΥΚΛΙΚΟΥ
ΕΠΙΠΛΕΟΝ 8mm 30m



20.605 - ΚΥΚΛΙΚΟ ΣΩΣΙΒΙΟ Φ75cm
SOLAS 74 LSA CODE 2.5 kg

20.606 - ΚΥΚΛΙΚΟ ΣΩΣΙΒΙΟ Φ75cm
SOLAS 74 LSA CODE 4.0 kg



20.607
ΚΥΚΛΙΚΟ ΣΩΣΙΒΙΟ Φ60cm
SOLAS 74 LSA CODE 2.5kg



99.525
ΣΤΟΛΗ ΞΕΜΒΑΠΤΙΣΕΩΣ



99.951
ΑΝΑΠΝΕΥΣΤΙΚΗ ΣΥΣΚΕΥΗ
ΔΙΑΦΥΓΗΣ 15min ΕΕΒΔ



99.952
ΑΝΑΠΝΕΥΣΤΙΚΗ ΣΥΣΚΕΥΗ 6Lτ
ΠΕΠΙΕΣΜΕΝΟΥ ΑΕΡΑ ΣΤΑ 300 bar



22.021
ΣΙΑΛΟΥΜ



21.029
ΣΤΟΛΗ ΘΕΡΜΙΚΗΣ ΠΡΟΣΤΑΣΙΑΣ
ΤΡΑ SOLAS



99.954
ΦΙΑΛΗ ΜΕ ΒΑΛΒΙΔΑ
ΑΝΤΑΛΛΑΚΤΙΚΗ



22.616
ΣΧΟΙΝΙ ΚΥΚΛΙΚΟΥ
THROW LINE

ΣΩΣΤΙΚΟΙ ΦΑΝΟΙ

ΣΩΣΤΙΚΟΣ ΕΞΟΠΛΙΣΜΟΣ



16.161

ΛΑΜΠΑ ΘΥΕΛΛΗΣ



20.505

ΑΝΑΤΡΕΠΟΜΕΝΗ ΛΥΧΝΙΑ
SOLAS 74/96



20.507

ΑΝΑΤΡΕΠΟΜΕΝΗ ΛΥΧΝΙΑ LED
ΜΕ ΣΕΝΣΟΡΑ ΚΑΙ ΜΠΑΤΑΡΙΑ
ΛΙΘΙΟΥ / SOLAS 74/96



20.504

ΒΑΣΗ ΙΝΟΧ
ΑΝΑΤΡ/ΝΗΣ ΛΥΧΝΙΑΣ



20.508

ΒΑΣΗ ΑΝΑΤΡ/ΝΗΣ
ΛΥΧΝΙΑΣ ΠΛΑΣΤΙΚΗ



21.027

ΦΩΤΑΚΙ ΣΩΣΙΒΙΩΝ LED
ΑΥΤΟ



14.025

ΦΑΝΑΡΑΚΙ 3 ΘΕΣΕΩΝ
LED ΜΠΑΤΑΡΙΑΣ



14.024

ΦΑΝΑΡΑΚΙ 3 ΘΕΣΕΩΝ
ΜΠΑΤΑΡΙΑΣ
ΛΕΥΚΟ-ΚΟΚΚΙΝΟ-ΠΡΑΣΙΝΟ

ΣΗΜΑΤΑ ΔΙΑΣΩΣΗΣ

ΣΩΣΤΙΚΟΣ ΕΞΟΠΛΙΣΜΟΣ



20.631

ΜΠΑΛΑ ΑΚΥΒΕΡΝΗΣΙΑΣ



20.632

ΚΩΝΟΣ ΜΑΥΡΟΣ



22.001 - ΣΗΜΑ ΚΙΝΔΥΝΟΥ

22.002 - ΣΗΜΑ ΚΑΠΝΟΥ

22.003 - ΣΗΜΑ ΑΛΕΞΙΠΤΩΤΟΥ



91.004

ΣΥΣΚΕΥΗ Μ Ο Β
ΚΑΠΝΟΓΟΝΟ ΓΕΦΥΡΑΣ



99.251

ΟΡΜΙΔΟΒΟΛΟΣ
ΣΥΣΚΕΥΗ



ΔΟΧΕΙΟ ΑΠΟΘΗΚΕΥΣΗΣ

12.101 6 Lt 20x25cm

12.102 8 Lt 25x26cm

12.103 12 Lt 38x25cm

12.104 15 Lt 44x25cm



ΤΣΑΝΤΑ ΑΔΙΑΒΡΟΧΗ

21.208 5Lt 40x15cm

21.206 12Lt 50x20cm

21.209 20Lt 50x25cm



ΚΩΔΙΚΟΣ	ΧΩΡΗΤ/ΤΑ lt	ΜΗΚΟΣ cm	ΒΑΘΟΣ cm	ΥΨΟΣ cm
12.111	5	21	17	21
12.112	10	21	17	36
12.113	20	35	29	33
12.114	30	35	29	43



93.130

ΘΗΚΗ ΕΓΓΡΑΦΩΝ
ΑΔΙΑΒΡΟΧΗ 27x35cm

LIFERAFT ISO 9650-1



ΚΩΔ.	ΑΤΟΜΑ	ΚΟΝΤΕΪΝΕΡ	ΒΑΡΟΣ kg	ΒΑΛΙΤΣΑ	ΒΑΡΟΣ kg
20.704	4	L77xW51xH33cm	48	L65xW42xH26cm	35
20.705	6	L77xW51xH33cm	50	L70xW45xH29cm	42
20.706	8	L77xW51xH34cm	58	L70xW48xH29cm	45
20.707	10	L82xW56xH35cm	63	L75xW48xH29cm	52
20.712	12	L92xW56xH33cm	68	L83xW48xH30cm	60



ΚΩΔΙΚΟΣ	ΑΤΟΜΑ	ΚΑΝΙΣΤΡΟ ΜΗΚΟΣ mm	ΚΑΝΙΣΤΡΟ ΠΛΑΤΟΣ mm
20.710	10	1.260	650
20.713	12	1.320	680
20.716	16	1.380	700
20.725	25	1.520	700
20.750	50	1.900	860



20.701
ΒΑΣΗ LIFERAFT INOX SS316
ΤΗΛΕΣΚΟΠΙΚΗ 100 x 44cm



21.023
ΦΑΝΟΣ LIFERAFT
SOLAS



21.026
ΦΑΝΟΣ LIFERAFT ΜΙΚΡΟΣ
SOLAS



21.024
ΥΔΡΟΣΤΑΤΙΚΗ ΒΑΛΒΙΔΑ INOX
CCS RELEASE UNIT



21.131
ΑΣΘΕΝΗΣ ΣΥΝΔΕΣΜΟΣ



16.321
ΜΑΧΑΙΡΙ LIFERAFT



- 24.508 - ΛΟΥΚΕΤΟ ΙΝΟΧ Φ30mm
- 24.509 - ΛΟΥΚΕΤΟ ΙΝΟΧ Φ40mm
- 24.510 - ΛΟΥΚΕΤΟ ΚΙΤ 5 ΛΟΥΚΕΤΑ ΙΝΟΧ Φ30mm
- 24.513 - ΛΟΥΚΕΤΟ ΚΙΤ 4 ΛΟΥΚΕΤΑ ΙΝΟΧ Φ30mm



- 21.125
ΓΑΝΤΖΟΣ ΓΙΑ ΙΜΑΝΤΑ
ΑΣΦΑΛΕΙΑΣ
ΟΡΙΟ ΘΡΑΥΣΗΣ 2000kg



- 20.625
ΤΑΙΝΙΑ ΑΝΑΚΛΑΣΤΙΚΗ
SOLAS 45m



- ΣΦΗΝΕΣ ΞΥΛΙΝΕΣ ΣΕΤ
- 95.077 8-38mm
- 95.080 20-49mm



- 21.122
ΙΜΑΝΤΑΣ ΑΣΦΑΛΕΙΑΣ
ΜΟΝΟ ΓΑΝΤΖΟ 2m



- 21.123
ΙΜΑΝΤΑΣ ΑΣΦΑΛΕΙΑΣ
ΔΙΠΛΟ ΓΑΝΤΖΟ 2m



- 99.993
ΚΑΘΡΕΦΤΑΚΙ ΣΗΜΑΝΣΗΣ



- 20.511
ΚΑΘΙΣΜΑ ΑΝΕΛΚΥΣΗΣ
ΣΕ ΑΛΜΠΟΥΡΟ
(ΚΑΝΤΙΛΙΤΣΑ)



- 21.121
ΖΩΝΗ + ΙΜΑΝΤΑΣ
ΑΣΦΑΛΕΙΑΣ 2m



- 20.513
ΚΑΝΤΗΛΙΤΣΑ
ΕΝΙΣΧΥΜΕΝΗ ΜΑΛΑΚΟ
ΚΑΘΙΣΜΑ
NYLON-CORDURA



- 20.512
ΚΑΝΤΗΛΙΤΣΑ
ΕΝΙΣΧΥΜΕΝΗ ΣΚΛΗΡΟ
ΚΑΘΙΣΜΑ
NYLON-CORDURA



- 98.164
ΑΝΕΜΟΔΟΥΡΙ ΠΛΑΣΤΙΚΟ



- 93.214
ΚΑΜΠΑΝΑ ΣΚΑΦΟΥΣ
ΜΠΡΟΥΤΖΙΝΗ 175mm



- 11.950
ΣΚΑΝΤΑΓΙΟ



- 16.171
ΚΛΙΝΟΜΕΤΡΟ ΠΛΑΣΤΙΚΟ



- 99.997
ΒΙΛΑΙ ΔΕΡΜΑΤΙΝΟ



95.911
ΚΛΕΙΔΙ ΙΝΟΧ ΟΧΤΑΓΩΝΟ
ΓΙΑ ΤΑΠΕΣ



95.912
ΚΛΕΙΔΙ ΠΛΑΣΤΙΚΟ ΟΧΤΑΓΩΝΟ
ΓΙΑ ΤΑΠΕΣ



04.301
ΚΟΦΤΗΣ ΣΥΡΜΑΤΟΣΧΟΙΝΟΥ 60cm



ΜΑΝΕΛΑ ΕΠΙΠΛΕΟΥΣΑ
95.906 203mm
95.901 260mm



95.900
ΜΑΝΕΛΑ 10" ALUM.
ΠΛΑΣΤΙΚΗ ΛΑΒΗ
30KGS



95.902
ΜΑΝΕΛΑ
ALUMINIUM 254mm



99.755
ΚΙΤ ΦΟΥΣΚΩΤΟΥ
(ΚΟΛΛΑ + ΜΠΑΛΩΜΑ)



99.992
ΑΝΑΚΛΑΣΤΗΡΑΣ ΡΑΝΤΑΡ
ΙΣΤΙΟΠΛΟΙΚΟΥ L50cm



99.991
ΑΝΑΚΛΑΣΤΗΡΑΣ ΡΑΝΤΑΡ
215x215x300mm



ΠΡΟΣΤΑΤΕΥΤΙΚΟ ΚΑΛΥΜΜΑ
ΓΙΑ ΣΤΑΥΡΟΥΣ
96.403 4mm
96.404 6mm
96.405 8mm



ΤΑΙΝΙΑ ΣΚΑΦΟΥΣ
24.301 ΜΠΛΕ 50mm
24.302 ΚΟΚΚΙΝΗ 50mm
24.303 ΜΠΛΕ 30mm
24.304 ΛΕΥΚΗ 30mm



99.996 ΒΑΤΡΑΧΟΠΕΔΙΛΑ
A 39-40
B 41-42
C 43-44
D 45-46



99.994
ΜΑΣΚΑ ΑΝΑΠΝΕΥΣΤΗΡΑΣ



95.128
ΕΡΓΑΛΕΙΟΘΗΚΗ
ΣΕ ΤΣΑΝΤΑ



95.102
ΕΡΓΑΛΕΙΟΘΗΚΗ
ΜΙΚΡΗ



95.103
ΕΡΓΑΛΕΙΟΘΗΚΗ
ΜΕΓΑΛΗ ΙΤΑΛΙΑΣ



15.152 - ΜΗΧΑΝΙΣΜΟΣ ΚΟΡΝΑΣ
15.153 - ΦΙΑΛΗ ΚΟΡΝΑΣ



15.161
ΤΡΟΜΠΕΤΑ ΠΛΑΣΤΙΚΗ
(ΚΟΡΝΑ ΟΜΙΧΛΗΣ)



15.180
ΦΑΚΟΣ ΚΕΦΑΛΗΣ 2 LED
ΑΔΙΑΒΡΟΧΟΣ



98.189
ΑΝΕΜΟΜΕΤΡΟ ΨΗΦΙΑΚΟ



15.182 - ΦΑΚΟΣ ΣΤΕΓΑΝΟΣ LED



15.183
ΦΑΚΟΣ ΥΠΟΒΡΥΧΙΟΣ
30m LED



15.181
ΦΑΚΟΣ ΣΤΕΓΑΝΟΣ LED



16.121
ΚΥΑΛΙΑ ΙΤΑΛΙΑΣ 7x50



16.123
ΚΥΑΛΙΑ ΜΕ ΠΥΞΙΔΑ
7X50 ΕΠΑΓΓΕΛΜΑΤΙΚΑ



15.179
ΦΑΚΟΣ LED 300LM
ΑΔΙΑΒΡΟΧΟΣ



15.178
ΠΡΟΒΟΛΕΑΣ ΦΑΚΟΣ USB
LITHIUM -ΑΔΙΑΒΡΟΧΟΣ
IP67-500LM



99.756
ΚΙΤ ΕΠΙΣΚΕΥΗΣ ΠΑΝΙΩΝ



16.154
ΣΟΥΓΙΑΣ ΠΟΛΥΕΡΓΑΛΕΙΟ ΕΝΙΣΧΥΜΕΝΟΣ



16.151
ΣΟΥΓΙΑΣ ΙΝΟΧ



99.767
ΒΕΛΟΝΕΣ ΣΕΤ ΠΑΝΙΟΥ



99.768
ΠΡΟΣΤΑΤΕΥΤΙΚΟ ΠΑΛΑΜΗΣ
ΓΙΑ ΓΑΣΑ



99.769
ΕΡΓΑΛΕΙΟ ΓΑΣΑΣ
ΣΧΟΙΝΙΟΥ



99.766
ΝΗΜΑ MARLOW
ΚΕΡΩΜΕΝΟ Φ0,4mm

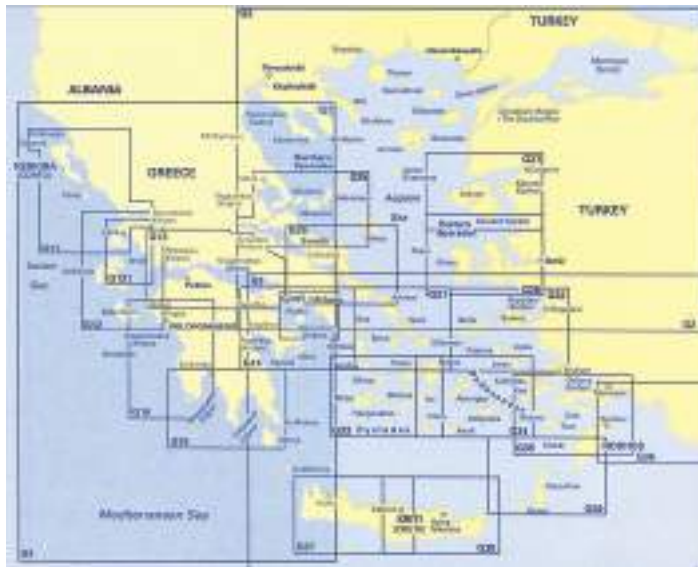

99.505xx - ΧΑΡΤΕΣ IMRAY

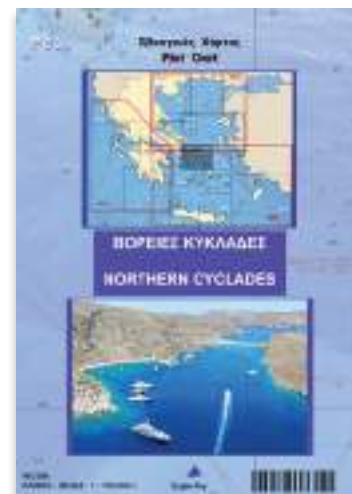

99.501XX - ΧΑΡΤΕΣ EAGLE RAY



99.302
ΦΑΡΟΔΕΙΚΤΗΣ



99.305
ΔΙΕΘΝΗΣ ΚΑΝΟΝΙΣΜΟΣ
ΑΠΟΦΥΓΗΣ ΣΥΓΚΡΟΥΣΕΩΝ



99.306
ΙΑΤΡΙΚΟΣ ΟΔΗΓΟΣ
ΑΓΓΛΙΚΟΥ ΕΡΥΘ.ΣΤΑΥΡΟΥ



99.303
ΠΙΝΑΚΑΣ ΣΗΜΑΤΩΝ



99.304
GREEK WATERS PILOT



99.304B
ADRIATIC PILOT



99.304C
ITALIAN WATERS PILOT



16.131
ΔΙΠΑΡΑΛΛΗΛΟΣ ΠΛΑΣΤΙΚΟΣ 30cm

16.132
ΔΙΠΑΡΑΛΛΗΛΟΣ ΠΛΑΣΤΙΚΟΣ 40cm



16.133
ΜΟΙΡΟΓΝΩΜΟΝΙΟ



16.141
ΚΟΥΜΠΑΣΟ



22.062 ΣΗΜΑΙΕΣ ΞΕΝΩΝ ΚΡΑΤΩΝ 40cm

22.061 ΣΗΜΑΙΕΣ ΕΕ 40cm



22.050 ΣΗΜΑΙΕΣ ΝΑΥΤΙΚΟΣ ΚΩΔΙΚΑΣ (ΣΕΤ 40ΤΕΜ.) 30x42cm



22.060 ΣΗΜΑΙΑ ΣΕΤ N & C

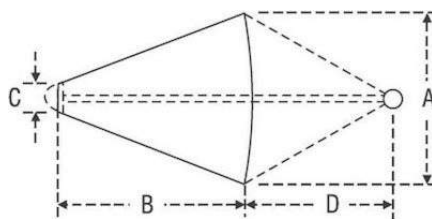

ΠΛΩΤΗ ΑΓΚΥΡΑ

ΚΩΔΙΚΟΣ	ΠΕΡΙΓΡΑΦΗ	A cm	B cm	C cm	D cm	ΣΚΑΦΟΣ mt
21.061	No1	55	50	10	65	<4.5
21.062	No2	65	70	12	70	<7
21.063	No3	115	115	19	90	<8,5
21.064	No4	145	140	22	125	<10
21.065	No5	193	152	35	130	<13.5
21.067	B.T. ΨΑΡΕΜΑΤΟΣ	270	210	60	240	>15



ΕΛΛΗΝΙΚΕΣ ΣΗΜΑΙΕΣ

- 22.041 ΤΡΙΓΩΝΗ 35 cm
- 22.042 ΤΡΙΓΩΝΗ 50 cm
- 22.043 ΤΡΙΓΩΝΗ 100 cm
- 22.030 ΠΑΡΑΛΛ/ΜΗ 30 cm
- 22.051 ΠΑΡΑΛΛ/ΜΗ 40 cm
- 22.052 ΠΑΡΑΛΛ/ΜΗ 50cm
- 22.053 ΠΑΡΑΛΛ/ΜΗ 60cm
- 22.054 ΠΑΡΑΛΛ/ΜΗ 75 cm
- 22.055 ΠΑΡΑΛΛ/ΜΗ 100 cm
- 22.056 ΠΑΡΑΛΛ/ΜΗ 120cm
- 22.557 ΠΑΡΑΛΛ/ΜΗ 150cm
- 22.558 ΠΑΡΑΛΛ/ΜΗ 200cm



96.475 ΚΟΥΒΑΔΑΚΙ ΜΙΚΡΟ



96.465 ΚΟΥΒΑΔΑΚΙ ΟΡΤΙΜΙΣΤ



22.012 - ΠΥΡΟΣΒΕΣΤΗΡΑΣ Ξ.ΚΟΝΕΩΣ 1 kg

99.508 - ΠΥΡΟΣΒΕΣΤΗΡΑΣ Ξ.ΚΟΝΕΩΣ 3 kg

99.507 - ΠΥΡΟΣΒΕΣΤΗΡΑΣ Ξ.ΚΟΝΕΩΣ 6 kg



99.506 ΘΥΡΑ ΠΥΡΟΣΒΕΣΤΗΡΑ



22.011

ΠΥΡΟΣΒΕΣΤΗΡΑΣ 0,75 kg



22.031 ΦΑΡΜΑΚΕΙΟ ΜΙΚΡΟ

ΠΕΡΙΕΧΟΜΕΝΟ:

1. ΛΕΥΚΟΠΛΑΣΤ
2. ΠΑΝΑΚΙΑ ΟΙΝΟΠΝΕΥΜΑ
3. ΒΑΜΒΑΚΙ
4. ΧΑΡΤΟΜΑΝΤΗΛΑ



22.032 ΦΑΡΜΑΚΕΙΟ ΜΕΓΑΛΟ

ΠΕΡΙΕΧΟΜΕΝΟ:

1. ΛΕΥΚΟΠΛΑΣΤ
2. ΠΑΝΑΚΙΑ ΟΙΝΟΠΝΕΥΜΑ
3. ΒΑΜΒΑΚΙ
4. ΧΑΡΤΟΜΑΝΤΗΛΑ
5. ΓΑΖΕΣ
6. ΓΑΝΤΙΑ



22.033 ΦΑΡΜΑΚΕΙΟ ΙΤΑΛΙΑΣ ΜΕ ΒΑΣΗ

ΠΕΡΙΕΧΟΜΕΝΟ:

- ΤΕΜ. 1 ΤΡΙΓΩΝΙΚΟ ΠΑΝΙ TNT 96X96X136 CM
- ΤΕΜ. 1 ΒΑΜΒΑΚΙ 5 ΓΡ. ΣΕ ΘΗΚΗ
- ΤΕΜ. 1 ΕΠΙΔΕΣΜΟΣ 3.5 ΜΧ7 ΣΜ ΣΕ ΣΕΛΟΦΑΝ
- ΤΕΜ. 1 ΡΟC. 5 Μ Χ 1,25 ΤΝΤ ΛΕΥΚΟ ΤΣΙΡΟΤΟ,
- ΤΕΜ. 2 ΓΑΖΕΣ 18Χ40 ΑΠΟΣΤΕΙΡΩΜΕΝΟ ΜΟΝΟ
- ΠΟΣ. 1 ΚΟΥΤΙ 10 ΔΙΑΦΟΡΩΝ ΤΣΙΡΟΤΩΝ
- ΠΟΣ. 1 ΣΤΔ ΨΑΛΙΔΙ 10 CM ΠΛΑΣΤΙΚΗ ΛΑΒΗ
- ΠΟΣΟΤΗΤΑ 1 ΓΑΝΤΙΑ CΟΡΟΛΙΜ ΖΕΥΓΑΡΙ ΑΠΟΣΤΕΙΡΩΜΕΝΑ ΜΟΝ. ΜΕΓΕΘΟΣ
- ΤΕΜ 3 ΜΑΝΤΗΛΑΚΙΑ ΑΠΟΛΥΜΑΝΤΙΚΩΝ ΡΜC
- ΤΕΜ 1 ΜΙΚΡΟΣ ΣΤΑΥΡΟΣ ΡVΣ ΛΕΥΚΟΣ/ΠΡΑΣΙΝΟΣ
- ΠΟΣ 1 ΕΓΧΕΙΡΙΔΙΟ LEBENSRETTENDE SOFORTMASSNAHMEN.



22.036 ΦΑΡΜΑΚΕΙΟ CE BOX 1

ΠΕΡΙΕΧΟΜΕΝΟ:

1. ΚΑΡΔΙΟΚΥΚΛΟΦΟΡΙΚΑ 1. CARDIOVASCULAR TAB/AMP 6%
2. ΑΝΤΙΣΤΗΘΑΓΧΙΚΑ ΧΑΠΙΑ 2. ANTIANGINAL PILLS/TAB 6%
3. ΑΝΤΙΟΞΙΝΑ ΧΑΠΙΑ 3. ANTIACIDS TAB 6%
4. ΑΝΤΙΕΜΕΤΙΚΑ 4. ANTIEMETICS TAB/CPS 6%
5. ΑΝΤΙΔΙΑΡΡΟΪΚΑ 5. ANTIARRHEAL TAB/CPS 6%
6. ΑΝΑΛΓΗΤΙΚΑ-ΑΝΤΙΠΥΡΕΤΙΚΑ 6. ANALGETICS-ANTIFEVER TAB/C 6%
7. ΣΠΑΣΜΟΛΥΤΙΚΑ ΧΑΠΙΑ 7. GASTROINTESTINAL ANTISPASMODICS 6%
8. ΑΝΤΙΣΗΠΤΙΚΟ ΔΙΑΛΥΜΑ 8. ANTISEPTIC SOLUTION 6%
9. ΣΚΕΥΑΣΜΑ ΚΑΤΑ ΤΩΝ ΕΓΚΑΥΜΑΤΩΝ 9. BURN PREPARATION 13%
10. ΣΥΣΚΕΥΗ ΑΝΑΝΗΨΗΣ ΑΠΟ ΣΤΟΜΑ ΣΕ ΣΤΟΜΑ 10. MOUTH TO MOUTH RECOVERY DEVICE/MASK 13% ΤΥΠΟΥ BROOK ΜΕ ΒΑΛΒΙΔΑ ΚΑΙ ΦΙΛΤΡΟ BROOK TYPE WITH ONE WAY VALVE AND FILTER
11. ΑΙΜΟΣΤΑΤΙΚΟΣ ΕΠΙΔΕΣΜΟΣ ΤΥΠΟΥ TOURNIQUET ESMAR 11. HEMOSTATIC BANDAGE TOURNIQUET-ESMAR 13%
12. ΕΠΙΔΕΣΜΟΣ ΑΥΤΟΣΥΓΚΡΑΤΟΥΜΕΝΟΣ ΕΛΑΣΤΙΚΟΣ 12. SELFADHESIVE ELASTICBANDAG 13%
13. ΕΠΙΘΕΜΑΤΑ ΑΠΟΣΤΕΙΡΩΜΕΝΗΣ ΓΑΖΑΣ 13. STERILISED GAUZES PADS COMPRESSES 13%
14. ΓΑΝΤΙΑ ΜΙΑΣ ΧΡΗΣΗΣ 14. DISPOSABLE POLYTH. GLOVES 6%
15. ΑΥΤΟΚΟΛΛΗΤΟΙ ΕΠΙΔΕΣΜΟΙ 15. ADHESIVE DRESSING -STRIPS 13%
16. ΑΠΟΣΤΕΙΡΩΜΕΝΟΣ ΠΙΕΣΤΙΚΟΣ ΕΠΙΔΕΣΜΟΣ 16. STERILISED COMPRESSION BANDAGE 13%
17. ΑΥΤΟΚΟΛΛΗΤΑ ΡΑΜΜΑΤΑ 17. SELF ADHESIVE STITCHES 13%
18. ΑΠΟΣΤΕΙΡΩΜΕΝΟ ΤΟΥΛΙ ΓΙΑ ΕΓΚΑΥΜΑΤΑ ΜΕ ΥΔΡΟΓΕΛΗ 18. STERILISED TULLE WITH HYDROGEL F BURNS 13%
19. ΛΕΥΚΟΠΛΑΣΤΗΣ 19. ADHESIVE TAPE 13%
20. ΨΑΛΙΔΙ 20. SCISSORS 24%
21. ΙΑΤΡΙΚΟ ΘΕΡΜΟΜΕΤΡΟ 21. MEDICAL THERMOMETER 24%
22. ΣΥΡΙΓΓΕΣ ΜΙΑΣ ΧΡΗΣΗΣ 22. DISPOSABLE SYRINGES 24%
23. ΑΥΧΕΝΙΚΟ ΠΕΡΙΛΑΙΜΙΟ 23. CERVICAL COLLAR 13%



22.035 ΦΑΡΜΑΚΕΙΟ ΙΤΑΛΙΑΣ ΜΕΓΑΛΟ

ΠΕΡΙΕΧΟΜΕΝΟ:

- ΠΟΣΟΤΗΤΑ 6 ΓΑΖΑ 18Χ40 ΑΠΟΣΤΕΙΡΩΜΕΝΟ ΜΟΝΟ
- ΠΟΣΟΤΗΤΑ 1 ΑΠΟΛΥΜΑΝΤΙΚΟ FLAC ML.250 ΡΜC
- ΠΟΣΟΤΗΤΑ 4 ΕΠΙΔΕΣΜΟΣ CAMBRIC 4Χ5 CM
- ΠΟΣΟΤΗΤΑ 1 ΘΗΚΗ 10 ΠΟΙΚΙΛΙΑ ΣΟΒΑΔΩΝ
- ΠΟΣΟΤΗΤΑ 1 ΕΠΙΔΕΣΜΟΣ CAMBRIC Μ 4Χ7 CM
- ΠΟΣΟΤΗΤΑ 1 ΡΑΒΔΙ. ΜΤ 5Χ1,25 ΤΝΤ ΛΕΥΚΟ ΤΣΙΡΟΤΟ
- ΤΕΜ 2 ΣΥΜΠΙΕΣΜΕΝΟ ΒΑΜΒΑΚΙ GR.125
- ΤΕΜ 1 ΓΑΖΑ ACTIVE GRAS ΑΠΟΣΤΕΙΡΩΜΕΝΗ ΠΑΡΑΦΙΝΗΣ 10Χ10 CM
- ΤΕΜ 1 ΨΑΛΙΔΙ LISTER 14,5 DIN
- ΤΕΜΑ 1 ΑΙΜΟΣΤΑΤΙΚΟ ΠΙΑΤΟ ΝΙΤΡΙΛΙΟΥ,
- ΤΕΜ ΠΛΑΣΤΙΚΗ ΣΤΕΚΑ1 ΚΑΤΑΓΜΑΤΟΣ 22Χ3 ΕΚ.



22.034 ΦΑΡΜΑΚΕΙΟ SOLAS



90.612

ΣΕΤ ΣΚΕΥΩΝ ΜΑΓΕΙΡΙΚΗΣ



90.601

ΟΣΕΑΝ ΠΛΗΡΕΣ ΣΕΡΒΙΤΣΙΟ 20 ΤΕΜ
4 μεγάλα πιατα, 4 μικρά πιατα, 4 σουπας,
4 μπολ, 4 κουπες



90.604

ΣΕΡΒΙΤΣΙΟ POLARIS 16 ΤΕΜ
4 μεγάλα πιατα, 4 μικρά πιατα,
4 σουπας, 4 κουπες



90.602

ΒΟΑΤ ΣΕΡΒΙΤΣΙΟ 16 τεμ.



90.641

ΜΑΧΑΙΡΟΠΗΡΟΥΝΑ
ΣΕΤ ΙΝΟΧ



90.631

ΠΙΑΤΟ POLARIS
ΜΕΓΑΛΟ



90.632

ΠΙΑΤΟ POLARIS
ΜΙΚΡΟ



90.635

ΚΟΥΠΑ POLARIS
6τεμ



90.606

ΣΕΡΒΙΤΣΙΟ SQUARE 16 ΤΕΜ



90.654

ΚΟΥΠΑ SQUARE
6τεμ



90.611

ΠΟΤΗΡΙ ΑΘΡΑΥΣΤΟ
(ΣΕΤ 4ΤΕΜ)



90.613

ΠΟΤΗΡΙ ΝΕΡΟΥ
(ΣΕΤ 4 ΤΕΜ)



90.614

ΠΟΤΗΡΙ ΝΕΡΟΥ
(ΣΕΤ 4 ΤΕΜ)



90.618

ΠΟΤΗΡΙ ΝΕΡΟΥ
250ml (ΣΕΤ 4 ΤΕΜ)



ΠΙΑΤΟ SQUARE 6τεμ

90.651 ΜΕΓΑΛΟ

90.652 ΜΙΚΡΟ



90.653

ΠΙΑΤΟ ΣΟΥΠΑΣ
SQUARE 6τεμ



90.615

ΠΟΤΗΡΙ ΚΡΑΣΙΟΥ
(ΣΕΤ 4 ΤΕΜ)



90.616

ΠΟΤΗΡΙ ΚΡΑΣΙΟΥ
(ΣΕΤ 4 ΤΕΜ)



90.617

ΠΟΤΗΡΙ ΣΑΜΠΑΝΙΑΣ
130ml (ΣΕΤ 4 ΤΕΜ)



ΤΑΣΑΚΙ ΙΝΟΧ ΑΝΤΙΑΝΕΜΙΚΟ

90.003 ΜΠΛΕ / 90.004 ΚΟΚΚΙΝΟ



90.039

ΧΑΛΑΚΙ
WELCOME ON BOARD



90.046

ΧΑΛΑΚΙ ΔΕΛΦΙΝΙΑ
WELCOME ON BOARD



ΜΑΞΙΛΑΡΙ

93.090 370x450mm

93.091 370x1200mm



ΜΑΞΙΛΑΡΙ ΑΝΑΔΙΠΛΟΥΜΕΝΟ

93.092Α ΓΚΡΙ 93.092Β ΜΠΛΕ



90.045

ΧΑΛΑΚΙ ΞΙΦΙΑΣ
WELCOME ON BOARD



90.047

ΧΑΛΑΚΙ ΠΥΞΙΔΑ
WELCOME ON BOARD



**ΠΟΛΥΕΣΤΕΡΙΚΟΙ ΙΜΑΝΤΕΣ
ΜΕ ΤΟ ΜΕΤΡΟ**

21.099 A 25mm
21.100 B 50mm



21.101
**ΙΜΑΝΤΑΣ ΠΟΛΥΕΣΤΕΡΙΚΟΣ
ΜΕ ΚΑΣΤΑΝΙΑ 50mm x 6m 5 TONS**



**ΙΜΑΝΤΑΣ ΠΟΛΥΕΣΤΕΡΙΚΟΣ
ΜΕ ΠΟΡΠΗ**
21.081 25mm x 3m ΓΑΛΒΑΝΙΖΕ
21.082 25mm x 5m ΓΑΛΒΑΝΙΖΕ
21.083 25mm x 3m INOX
21.084 25mm x 5m INOX



21.141
**ΙΜΑΝΤΑΣ ΠΟΛΥΕΣΤΕΡΙΚΟΣ ΜΕ
ΑΝΟΞΕΙΔΩΤΗ ΚΑΣΤΑΝΙΑ ΚΑΙ
ΔΙΠΛΟ ΓΑΝΤΖΟ 25mm x 5m**



21.092
**ΙΜΑΝΤΑΣ ΠΟΛΥΕΣΤΕΡΙΚΟΣ
25mm X 5m ΜΕ ΓΑΛΒΑΝΙΖΕ
ΚΑΣΤΑΝΙΑ ΚΑΙ ΓΑΝΤΖΟ**



21.091
**ΙΜΑΝΤΑΣ ΠΟΛΥΕΣΤΕΡΙΚΟΣ
ΒΑΡΙΑΣ ΧΡΗΣΗΣ
ΜΕ ΚΑΣΤΑΝΙΑ 25mm x 6m**



21.143
**ΙΜΑΝΤΑΣ ΠΟΛΥΕΣΤΕΡΙΚΟΣ
ΜΕ ΑΝΟΞΕΙΔΩΤΗ ΚΑΣΤΑΝΙΑ
25mm x 6m**



00.032
**ΚΑΣΤΑΝΙΑ ΓΑΛΒΑΝΙΖΕ
50mm**



00.134
ΠΟΡΠΗ ΠΛΑΣΤΙΚΗ 30mm



00.034
**ΠΟΡΠΗ ΠΛΑΣΤΙΚΗ ΣΩΣΙΒΙΟΥ Β.Τ.
40mm ISO12402**



00.033
**ΚΑΣΤΑΝΙΑ ΓΑΛΒΑΝΙΖΕ
30mm**



90.001
ΠΟΡΠΗ ΓΑΛΒΑΝΙΖΕ 30mm



90.002
ΠΟΡΠΗ INOX 30mm



00.127
**ΚΑΣΤΑΝΙΑ INOX
30mm**



00.141
**ΓΑΝΤΖΟΣ ΙΜΑΝΤΑ INOX
25mm**



00.142
**ΓΑΝΤΖΟΣ ΙΜΑΝΤΑ ΓΑΛΒΑΝΙΖΕ
30mm**

ΕΞΟΠΛΙΣΜΟΣ ΤΡΕΪΛΕΡ



ΒΙΝΤΖΑΚΙ ΤΡΕΪΛΕΡ

- 23.001 600 LBS
- 23.002 1200 LBS
- 23.003 1400 LBS
- 23.004 2000 LBS
- 23.005 2500 LBS
- 23.006 3200 LBS
- 23.007 3700 LBS



ΒΙΝΤΖΙ ΤΡΕΪΛΕΡ ΙΝΟΧ

- 23.064 1600LBS
- 23.074 2000LBS



- 95.062 - ΜΑΝΕΛΑ ΒΙΝΤΖΙΟΥ ΕΩΣ 1400lbs
- 95.061 - ΜΑΝΕΛΑ ΒΙΝΤΖΙΟΥ ΕΩΣ 3700lbs



ΙΜΑΝΤΑΣ ΜΕ ΓΑΝΤΖΟ ΓΙΑ ΒΙΝΤΖΙ

- 23.031 4,5m
- 23.032 6,0m
- 23.033 7,5m



22.122 ΙΜΑΝΤΑΣ ΜΕ ΓΑΝΤΖΟ ΓΙΑ ΒΙΝΤΖΙ 6,5m ΕΝΙΣΧΥΜΕΝΟΣ



01.307

ΦΑΝΑΡΙ ΤΡΕΪΛΕΡ



ΦΑΝΑΡΙΕΡΑ

- 01.308 ΜΕ 4.5m ΚΑΛΩΔΙΟ
- 01.312 ΜΕ 7.5m ΚΑΛΩΔΙΟ



ΠΡΙΖΑ ΤΡΕΪΛΕΡ 7 PIN

- 01.406 ΘΗΛΥΚΗ ΜΕ ΚΑΠΑΚΙ
- 01.315 ΑΡΣΕΝΙΚΗ



ΦΑΝΑΡΙΑ ΜΑΓΝΗΤΙΚΑ

- 01.405 ΜΕ 7.5m ΚΑΛΩΔΙΟ
- 01.310 ΜΕ 12m ΚΑΛΩΔΙΟ



96.435

ΦΑΝΑΡΙΑ ΤΡΕΪΛΕΡ LED WIRELESS ΑΔΙΑΒΡΟΧΑ



01.411

ΦΑΝΑΡΙΕΡΑ ΜΑΓΝΗΤΙΚΗ 7,5 ΜΤ ΚΑΛΩΔΙΟ LED



- 23.028 - ΧΟΥΦΤΑ ΤΡΕΪΛΕΡ W60mm
- 23.029 - ΧΟΥΦΤΑ ΤΡΕΪΛΕΡ W70mm
- 23.030 - ΧΟΥΦΤΑ ΤΡΕΪΛΕΡ W80mm



23.022
ΡΟΔΑΚΙ ΤΡΕΙΛΕΡ
ΜΕ ΣΦΙΓΚΤΗΡΑ 500LBS



23.024
ΡΟΔΑΚΙ ΤΡΕΙΛΕΡ
1000LBS



23.023
ΡΟΔΑΚΙ ΤΡΕΙΛΕΡ
1.500 LBS



23.041
ΡΑΟΥΛΟ ΚΑΡΕΝΑΣ
Α: ΛΕΥΚΟ / Β:ΜΑΥΡΟ
L190xW95mm Φ21mm



23.042
ΡΑΟΥΛΟ ΚΑΡΕΝΑΣ
Α: ΛΕΥΚΟ / Β:ΜΑΥΡΟ
L115xW75mm Φ17mm



23.043
ΡΑΟΥΛΟ ΚΑΡΕΝΑΣ
Α: ΛΕΥΚΟ / Β:ΜΑΥΡΟ
L115x85mm Φ17mm



23.051
ΡΑΟΥΛΟ ΠΛΕΥΡΙΚΟ
ΛΑΣΤΙΧΟ L115xW70m
Φ17mm



23.052
ΡΑΟΥΛΟ ΠΛΕΥΡΙΚΟ
ΠΛΑΣΤΙΚΟ L105xW70mm
ΤΡΑΚΤΕΡΩΤΟ Φ17mm



23.053
ΡΑΟΥΛΟ ΠΛΕΥΡΙΚΟ
ΠΛΑΣΤΙΚΟ ΛΕΙΟ
L105xW70mm
ΤΡΥΠΑ 17mm



23.044
ΡΑΟΥΛΟ ΚΑΡΕΝΑΣ
L140xW70mm
Φ17mm



23.065
ΡΑΟΥΛΟ ΠΛΩΡΗΣ
Α: ΛΕΥΚΟ / Β:ΜΑΥΡΟ
L78xW75mm Φ13mm



23.045
ΡΑΟΥΛΟ ΠΛΩΡΗΣ
Α: ΛΕΥΚΟ / Β:ΜΑΥΡΟ
L110xW100mm Φ17mm



23.067
ΡΑΟΥΛΟ ΠΛΩΡΗΣ
Α: ΛΕΥΚΟ / Β:ΜΑΥΡΟ
L100xW75mm Φ12mm



23.068
ΡΑΟΥΛΟ ΠΛΕΥΡΙΚΟ
L90xW60mm
ΛΑΣΤΙΧΟ Φ17mm



23.069
ΡΑΟΥΛΟ ΠΛΕΥΡΙΚΟ
L105xW82mm
ΛΑΣΤΙΧΟ Φ17mm



23.070
ΡΑΟΥΛΟ ΠΛΕΥΡΙΚΟ
L130xW80mm
ΛΑΣΤΙΧΟ Φ21mm



23.071
ΡΑΟΥΛΟ ΠΛΕΥΡΙΚΟ
L90xW65mm
ΛΑΣΤΙΧΟ Φ17mm
Α: ΛΕΥΚΟ / Β:ΜΑΥΡΟ



- 24.617**
ΤΡΟΜΠΑ ΗΛΕΚΤΡΙΚΗ ΒΤΡ12
- 12V
 - ΜΕ ΜΑΝΟΜΕΤΡΟ
 - ΕΩΣ 1000 ΜΒΑΡ/14,5 PSI
 - ΠΑΡΟΧΗ ΑΕΡΑ 450LT/MIN



- 24.613**
ΤΡΟΜΠΑ ΗΛΕΚΤΡΙΚΗ ΒΡ12
- 12V
 - ΜΕ ΡΥΘΜΙΣΤΗ ΠΙΕΣΕΩΣ
 - ΕΩΣ 1000 ΜΒΑΡ/14,5 PSI
 - ΠΑΡΟΧΗ ΑΕΡΑ 160LT/MIN



- 24.057**
ΤΡΟΜΠΑ ΗΛΕΚΤΡΙΚΗ ΒΣΤ 12 ΗΡ
- 12V
 - ΜΕ ΡΥΘΜΙΣΤΗ ΠΙΕΣΕΩΣ
 - ΕΩΣ 800 ΜΒΑΡ /11.6 PSI
 - ΠΑΡΟΧΗ ΑΕΡΑ ΕΩΣ 450LT/MIN



- 24.064**
ΤΡΟΜΠΑ ΗΛΕΚΤΡΙΚΗ TURBO MAX
- 12V
 - ΜΕ ΡΥΘΜΙΣΤΗ ΠΙΕΣΕΩΣ
 - ΕΩΣ 250 ΜΒΑΡ/3.6 PSI
 - ΠΑΡΟΧΗ ΑΕΡΑ 1000LT/MIN

- 24.067**
ΑΝΤΑΛΛΑΚΤΙΚΟΣ ΚΟΝΕΚΤΟΡΑΣ & ΣΩΛΗΝΑΣ ΤΡΟΜΠΑΣ TURBO MAX



- 24.620**
ΤΡΟΜΠΑ ΗΛΕΚΤΡΙΚΗ
- 230V
 - ΕΩΣ 90 ΜΒΑΡ/2.8 PSI
 - ΠΑΡΟΧΗ ΑΕΡΑ 800L/MIN



- 24.612**
ΤΡΟΜΠΑ ΗΛΕΚΤΡΙΚΗ
- 230V
 - ΕΩΣ 230 ΜΒΑΡ/3.3 PSI
 - ΠΑΡΟΧΗ ΑΕΡΑ 1500LT/MIN



- 24.061**
ΤΡΟΜΠΑ ΗΛΕΚΤΡΙΚΗ
- 230V
 - 5,3PSI
 - 3400LT/M



- 24.065**
ΤΡΟΜΠΑ ΗΛΕΚΤΡΙΚΗ GE21-1
- 12V
 - ΜΕ ΡΥΘΜΙΣΤΗ ΠΙΕΣΕΩΣ
 - ΕΩΣ 1500 ΜΒΑΡ /22,5 PSI
 - ΠΑΡΟΧΗ ΑΕΡΑ 150LT/MIN



- 24.068**
ΤΡΟΜΠΑ ΗΛΕΚΤΡΙΚΗ
- 230V
 - 3,6PSI
 - 3400LT/M



- 24.622**
ΤΡΟΜΠΑ SUP
- 12V
 - ΜΕ ΡΥΘΜΙΣΤΗ ΠΙΕΣΕΩΣ
 - ΕΩΣ 1500 ΜΒΑΡ /22,5 PSI



- 24.060**
ΤΡΟΜΠΑ SUP GE 20-1
- 12V
 - ΜΕ ΡΥΘΜΙΣΤΗ ΠΙΕΣΕΩΣ
 - ΕΩΣ 1500 ΜΒΑΡ /22,5 PSI
 - ΠΑΡΟΧΗ ΑΕΡΑ ΕΩΣ 125LT/MIN



24.069
ΤΡΟΜΠΑ SUP 0-20PSI 14.8V
ΜΕ ΜΠΑΤΑΡΙΑ ΛΙΘΙΟΥ



24.621
ΤΡΟΜΠΑ SUP
• 12V
• ΕΩΣ 1000 ΜΒΑΡ/15 PSI
• ΜΕ ΡΥΘΜΙΣΤΗ ΠΙΕΣΕΩΣ



24.614
ΤΡΟΜΠΑ ΧΕΙΡΟΚΙΝΗΤΗ
BRAVO 4 SH
• 500mbar/7,2 PSI
• ΔΙΠΛΗΣ ΕΝΕΡΓΕΙΑΣ
• ΧΩΡΗΤΙΚΟΤΗΤΑ
2x2000cc



24.053
ΤΡΟΜΠΑ ΧΕΙΡΟΚΙΝΗΤΗ
BRAVO 6
• 600mbar/8,7 PSI
• ΔΙΠΛΗΣ ΕΝΕΡΓΕΙΑΣ
• ΧΩΡΗΤΙΚΟΤΗΤΑ
2x2500cc



24.626
ΤΡΟΜΠΑ
ΧΕΙΡΟΚΙΝΗΤΗ
SUP1bar/14.5PSI
• ΔΙΠΛΗΣ ΕΝΕΡΓΕΙΑΣ
• ΧΩΡΗΤΙΚΟΤΗΤΑ
2x2500cc



24.056
ΤΡΟΜΠΑ
ΧΕΙΡΟΚΙΝΗΤΗ SUP
1bar/14.5PSI
• ΔΙΠΛΗΣ ΕΝΕΡΓΕΙΑΣ
• ΧΩΡΗΤΙΚΟΤΗΤΑ
2x2500cc



24.625
ΤΡΟΜΠΑ
ΧΕΙΡΟΚΙΝΗΤΗ
SUP1bar/14.5PSI
• ΔΙΠΛΗΣ ΕΝΕΡΓΕΙΑΣ
• ΧΩΡΗΤΙΚΟΤΗΤΑ
2x2500cc



24.052
ΤΡΟΜΠΑ
ΠΟΔΟΚΙΝΗΤΗ
ΕΝΙΣΧΥΜΕΝΗ
BRAVO 1
• 200ΜΒΑΡ/2.9 PSI
• 5 Lt



24.051
ΤΡΟΜΠΑ
ΠΟΔΟΚΙΝΗΤΗ
• 5 Lt



24.623
ΣΩΛΗΝΑΣ & ΣΥΝΔΕΣΕΙΣ
OV10 - OV6 - GE 2000



24.616
ΣΩΛΗΝΑΣ & ΣΥΝΔΕΣΕΙΣ
ΓΙΑ ΒΤΡ1-ΒΡ12-ΒΤΡ12



24.628
ΒΑΛΒΙΔΑ ΑΝΤΑΛΑΚΤΙΚΗ ΤΡΟΜΠΑΣ



24.615
ΒΑΛΒΙΔΑ ΤΡΟΜΠΑΣ
ΦΟΥΣΚΩΤΟΥ



24.624
ΒΑΛΒΙΔΑ ΤΡΟΜΠΑΣ 718



24.054
ΜΑΝΟΜΕΤΡΟ ΠΙΕΣΗΣ
ΓΙΑ ΤΡΟΜΠΕΣ



24.066
ΜΑΝΟΜΕΤΡΟ SUP



24.624
ΕΞΑΡΤΗΜΑΤΑ ΒΑΛΒΙΔΑΣ
ΤΡΟΜΠΑΣ SP712



23.063

ΡΟΔΑΚΙ ΦΟΥΣΚΩΤΟΥ ΙΝΟΧ Φ36CM (ΣΕΤ)



97.131

ΡΟΔΑ ΓΙΑ ΚΑΒΑΛΕΤΟ Φ22



ΚΟΥΠΙ ΜΕ ΤΡΥΠΑ ΓΙΑ ΦΟΥΣΚΩΤΑ

24.058 40 X 60cm

24.059 50 X 60cm



ΚΟΥΠΙ ΓΙΑ ΦΟΥΣΚΩΤΑ

24.158 1,36m

24.159 1,65m



ΑΝΤΑΛΛΑΚΤΙΚΟ ΠΑΤΩΜΑ ΦΟΥΣΚΩΤΟΥ

17.021 2,3M

17.022 2,5M

17.023 2,7M



23.062

ΡΟΔΑΚΙΑ ΦΟΥΣΚΩΤΟΥ ΜΙΚΡΗ ΡΟΔΑ ΠΛΑΣΤΙΚΗ



17.025

ΑΝΤΑΛΑΚΤΙΚΗ ΤΑΠΑ ΦΟΥΣΚΩΤΟΥ



17.026

ΑΝΤΑΛΑΚΤΙΚΗ ΤΑΠΑ ΦΟΥΣΚΩΤΟΥ



95.065

ΙΜΑΝΤΑΣ ΑΝΥΨΩΣΗΣ ΦΟΥΣΚΩΤΟΥ



17.009

ΑΝΤΑΛΛΑΚΤΙΚΟ ΚΑΘΙΣΜΑ ΦΟΥΣΚΩΤΟΥ



17.007

ΑΝΤΑΛΛΑΚΤΙΚΟΣ ΣΚΑΡΜΟΣ ΦΟΥΣΚΩΤΩΝ



17.006

ΜΠΙΛΙΑ ΑΝΤΑΛΑΚΤΙΚΗ ΓΙΑ ΚΟΥΠΙ ΦΟΥΣΚΩΤΟΥ



99.755

ΚΙΤ ΦΟΥΣΚΩΤΟΥ (ΚΟΛΛΑ + ΜΠΑΛΩΜΑ)



99.739

ΚΑΘΙΣΜΑ ΦΟΥΣΚΩΤΟΥ ΡΥΘΜΙΖΟΜΕΝΟ ΜΕ LOCKER



21.207

ΤΣΑΝΤΑ ΠΛΩΡΗΣ ΦΟΥΣΚΩΤΟΥ



21.210

ΤΣΑΝΤΑ ΚΑΘΙΣΜΑΤΟΣ ΦΟΥΣΚΩΤΟΥ



95.001
95.007
95.008

95.009*
95.010*
95.011*

Βασικός Εξοπλισμός

- Τσάντα μεταφοράς
- Αφαιρούμενο κάθισμα
- Κιτ επισκευής
- Κουπιά αλουμινίου (σετ)
- Τρόμπα ποδιού

ΦΟΥΣΚΩΤΑ ΜΕ ΠΗΧΑΚΙΑ

ΚΩΔΙΚΟΣ	ΜΗΚΟΣ cm	ΠΛΑΤΟΣ cm	ΔΙΑΜ. ΜΠΑΛΟΝΙΟΥ cm	ΑΡ. ΜΠΑΛΟΝΙΩΝ	ΚΙΛΑ kg	ΜΕΓ. ΔΥΝΑΜΗ hp	ΜΕΓ. ΦΟΡΤΙΟ kg	ΑΡ. ΑΤΟΜΩΝ
95.001	200	117	34	2	23	3,5	250	2
95.007	230	131	36	3	30	4	350	2
95.008	250	152	42	3	40	6	400	3
95.018	270	152	42	3	52	10	500	4
95.009*	200	131	34	3	23	3,5	250	2
95.010*	230	131	36	3	30	4	350	2
95.011*	250	152	42	3	40	6	400	3

*ΠΟΛΥΧΡΩΜΟ



Βασικός Εξοπλισμός

- Τσάντα μεταφοράς
- Αφαιρούμενο κάθισμα
- Κιτ επισκευής
- Κουπιά αλουμινίου (σετ)
- Τρόμπα ποδιού

ΦΟΥΣΚΩΤΑ ΜΕ ΦΟΥΣΚΩΤΟ ΠΑΤΩΜΑ

ΚΩΔΙΚΟΣ	ΜΗΚΟΣ cm	ΠΛΑΤΟΣ cm	ΔΙΑΜ. ΜΠΑΛΟΝΙΟΥ cm	ΑΡ. ΜΠΑΛΟΝΙΩΝ	ΚΙΛΑ kg	ΜΕΓ. ΔΥΝΑΜΗ hp	ΜΕΓ. ΦΟΡΤΙΟ kg	ΑΡ. ΑΤΟΜΩΝ
95.002	200	129,0	35	2+1	17,2	3,5	250	2
95.003	230	130,5	35	2+1	18,5	4,0	350	2
95.004	250	131,0	40	3+1	21,0	7,5	400	3

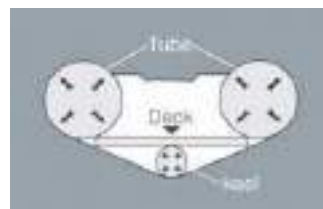

Βασικός Εξοπλισμός

- Τσάντα μεταφοράς
- Αφαιρούμενο κάθισμα
- Κιτ επισκευής
- Κουπία αλουμινίου (σετ)
- Τρόμπα ποδιού

ΦΟΥΣΚΩΤΑ ΜΕ ΦΟΥΣΚΩΤΗ ΓΑΣΤΡΑ "V"

ΚΩΔΙΚΟΣ	ΠΑΤΩΜΑ	ΜΗΚΟΣ cm	ΠΛΑΤΟΣ cm	ΔΙΑΜ. ΜΠΑΛΟΝΙΟΥ cm	ΑΡ. ΜΠΑΛΟΝΙΩΝ	ΒΑΡΟΣ kg	ΜΕΓ.ΔΥΝΑΜΗ hp	ΜΕΓ.ΦΟΡΤΙΟ kg	ΑΤΟΜΑ
95.012	ΦΟΥΣΚΩΤΟ	230	137	36	3+1	30	4	350	2
95.013	ΦΟΥΣΚΩΤΟ	250	150	42	3+1	36	7,5	450	3
95.005	ΦΟΥΣΚΩΤΟ	270	150	42	3+1	37	10	484	3.5
95.006	ΑΛΟΥΜΙΝΙΟ	320	151	42	3+1	56	15	566	4.5



Βασικός Εξοπλισμός

- Τσάντα μεταφοράς
- Αφαιρούμενο κάθισμα
- Κιτ επισκευής
- Κουπία αλουμινίου (σετ)
- Τρόμπα ποδιού

ΦΟΥΣΚΩΤΑ ΜΕ ΠΟΛΥΕΣΤΕΡΙΚΗ ΓΑΣΤΡΑ

ΚΩΔΙΚΟΣ cm	ΜΗΚΟΣ cm	ΠΛΑΤΟΣ cm	ΔΙΑΜ. ΜΠΑΛΟΝΙΟΥ cm	ΑΡΙΘΜΟΣ ΜΠΑΛΟΝΙΩΝ	ΒΑΡΟΣ kg	ΜΕΓ.ΔΥΝΑΜΗ hp	ΜΕΓ.ΦΟΡΤΙΟ kg	ΑΤΟΜΑ	ΓΑΣΤΡΑ
95.016	250	160	43	3	50.0	5	450	3	ΜΟΝΗ
95.017	290	160	43	3	65.0	10	550	3	ΜΟΝΗ
95.019	310	165	42	3	62.0	15	700	4	ΜΟΝΗ
95.015	330	165	42	3	68.0	20	600	5	ΔΙΠΛΗ

18.310 - ΜΠΑΛΟΝΙ ΚΑΤΡΑΚΥΛΙ F4 106X22cm

18.311 - ΜΠΑΛΟΝΙ ΚΑΤΡΑΚΥΛΙ F4 A 120X26cm



24.031-A - ΚΑΤΡΑΚΥΛΙ 125x25cm ΚΟΚΚΙΝΟ

24.031-B - ΚΑΤΡΑΚΥΛΙ 125x25cm ΚΙΤΡΙΝΟ





28.000 ΕΞΩΛΕΜΒΙΑ 2,5 HP

Τύπος κινητήρα	Τετράχρονος (SHORT)
Κυβισμός	72cm ³
Αρ. κυλίνδρων/Διάταξη	1,0 HV
Διαμέτρος x Διαδρομή	54,0 χλστ x 31,5 χλστ
Ιπποδύναμη στον άξονα της προπέλας	1,8 / 5,500 σ.α.λ.
Εύρος μέγιστων στροφών	5,250 - 5,750 rpm
Σύστημα λίπανσης	Πιτσίλισμα
Fuel Induction System	1 καρμπ.
Σύστημα ανάφλεξης	TCI
Σύστημα εκκίνησης	Χειροκίνητο
Σχέση μετάδοσης	2.08 (27:13)

28.001 ΕΞΩΛΕΜΒΙΑ 4,0 HP

Τύπος κινητήρα	Τετράχρονος (SHORT)
Κυβισμός	139 cm ³
Αρ. κυλίνδρων/Διάταξη	1, 0HV
Διαμέτρος x Διαδρομή	62.0 χλστ. x 46.0 χλστ.
Ιπποδύναμη στον άξονα της προπέλας	2.9 / 4,500 σ.α.λ.
Εύρος μέγιστων στροφών	4,000 - 5,000 rpm
Σύστημα λίπανσης	Υγρό κάρτερ
Fuel Induction System	1 καρμπ.
Σύστημα ανάφλεξης	CDI
Σύστημα εκκίνησης	Χειροκίνητο
Σχέση μετάδοσης	2.08 (27:13)



28.002 ΕΞΩΛΕΜΒΙΑ 5,0 HP

Τύπος κινητήρα	Τετράχρονος (SHORT)
Κυβισμός	139 cm ³
Αρ. κυλίνδρων/Διάταξη	1, 0HV
Διαμέτρος x Διαδρομή	62.0 χλστ. x 46.0 χλστ.
Ιπποδύναμη στον άξονα της προπέλας	3.7 / 5,000 σ.α.λ.
Εύρος μέγιστων στροφών	4,500 - 5,500 rpm
Σύστημα λίπανσης	Υγρό κάρτερ
Fuel Induction System	1 καρμπ.
Σύστημα ανάφλεξης	CDI
Σύστημα εκκίνησης	Χειροκίνητο
Σχέση μετάδοσης	2.08 (27:13)



28.003 ΕΞΩΛΕΜΒΙΑ 6,0 HP

Τύπος κινητήρα	Τετράχρονος (SHORT)
Κυβισμός	139 cm ³
Αρ. κυλίνδρων/Διάταξη	1, 0HV
Διαμέτρος x Διαδρομή	62.0 χλστ. x 46.0 χλστ.
Ιπποδύναμη στον άξονα της προπέλας	4.4 / 5,000 σ.α.λ.
Εύρος μέγιστων στροφών	4,500 - 5,500 rpm
Σύστημα λίπανσης	Υγρό κάρτερ
Fuel Induction System	1 καρμπ.
Σύστημα ανάφλεξης	CDI
Σύστημα εκκίνησης	Χειροκίνητο
Σχέση μετάδοσης	2.08 (27:13)





28.011 ΕΞΩΛΕΜΒΙΑ 2,3 HP

Τύπος Κινητήρα	Τετράχρονος, αερόψυκτος
Βαλβίδες	OHV μονοκύλινδρος
Κυβισμός (cc)	57
Διάμετρος x Διαδρομή (mm)	45 x 36
Εύρος Μέγιστων Στροφών (RPM)	5.000 - 6.000
Ονομαστική Ισχύς (kW(PS))	1,7 (2,3)
Σύστημα Ψύξης	Ψύξη αέρα
Παροχή Καυσίμου	1 καρμπυρατέρ
Σύστημα Ανάφλεξης	Με τρανζίστορ
Σύστημα Εκκίνησης	Χειροκίνητο
Σχέση Μετάδοσης	2,42
Φυγοκεντρικός Συμπλέκτης	Ναι
Περιστροφή Προπέλας	Standard
Ρύθμιση Κλίσης (trim) & Ανύψωσης (tilt) Μηχανής	Χειροκίνητη 4 σταδίων



28.012 ΕΞΩΛΕΜΒΙΑ 4,0 HP

Τύπος Κινητήρα	Τετράχρονος, μονοκύλινδρος
Βαλβίδες	OHV
Κυβισμός (cc)	127
Διάμετρος x Διαδρομή (mm)	60 x 45
Εύρος Μέγιστων Στροφών (RPM)	4.500 - 5.500
Ονομαστική Ισχύς (kW(PS))	2,9(4)
Σύστημα Ψύξης	Υδροψυκτος (με θερμοστάτη)
Παροχή Καυσίμου	1 καρμπυρατέρ
Σύστημα Ανάφλεξης	Ψηφιακός CDI
Σύστημα Εκκίνησης	Εκκίνηση με Κορδόνι (Κορδονιέρα)
Σχέση Μετάδοσης	2,08
Ρύθμιση Κλίσης (trim) & Ανύψωσης (tilt) Μηχανής	Χειροκίνητη ρύθμιση 5 σταδίων
Σύστημα Εξάτμισης	Μέσα στο νερό



28.013 ΕΞΩΛΕΜΒΙΑ 6,0 HP

Τύπος Κινητήρα	Τετράχρονος, μονοκύλινδρος
Βαλβίδες	OHV
Κυβισμός (cc)	127
Διάμετρος x Διαδρομή (mm)	60 x 45
Εύρος Μέγιστων Στροφών (RPM)	5.000 - 6.000
Ονομαστική Ισχύς (kW(PS))	4,4 (6)
Σύστημα Ψύξης	Υδροψυκτος (με θερμοστάτη)
Παροχή Καυσίμου	1 καρμπυρατέρ
Σύστημα Ανάφλεξης	Ψηφιακός CDI
Σύστημα Εκκίνησης	Εκκίνηση με Κορδόνι (Κορδονιέρα)
Σχέση Μετάδοσης	2,08
Ρύθμιση Κλίσης (trim) & Ανύψωσης (tilt) Μηχανής	Χειροκίνητη ρύθμιση 5 σταδίων
Σύστημα Εξάτμισης	Μέσα στο νερό



ΜΗΚΟΣ cm	3.35
ΠΛΑΤΟΣ cm	78
ΠΑΧΟΣ cm	15
ΒΑΡΟΣ kg	15
ΠΙΕΣΗ psi	12-15



- 95.021 ΦΟΥΣΚΩΤΟ SUP 11' 335 LBS (ONE LAYER)
- 95.024 ΦΟΥΣΚΩΤΟ SUP 11' 335 LBS (DOUBLE LAYER)



ΜΗΚΟΣ cm	3.05
ΠΛΑΤΟΣ cm	78
ΠΑΧΟΣ cm	15
ΒΑΡΟΣ kg	14
ΠΙΕΣΗ psi	12-15



- 95.020 ΦΟΥΣΚΩΤΟ SUP 10' 265 LBS (ONE LAYER)
- 95.023 ΦΟΥΣΚΩΤΟ SUP 10' 265 LBS (DOUBLE LAYER)



SUP ΠΛΑΣΤΙΚΟ

ΚΩΔΙΚΟΣ	ΜΗΚΟΣ cm	ΠΛΑΤΟΣ cm	ΥΨΟΣ cm	ΒΑΡΟΣ kg	ΒΑΡΟΣ ΦΟΡΤΩΣΗΣ	ΧΡΩΜΑ
95.028A	290	91	21	18,5	100kg	ΚΟΚΚΙΝΟ
95.028B	290	91	21	18,5	100kg	ΚΙΤΡΙΝΟ
95.028C	290	91	21	18,5	100kg	ΜΠΛΕ



95.040
SUP HESTIA RACER 12'6 PURE WHITE



95.031
ΑΝΤΑΛΑΚΤΙΚΟ FIN ΓΙΑ SUP



95.032
ΙΜΑΝΤΑΣ LEASH ΓΙΑ SUP



17.013
ΚΟΥΠΙ SUP 150-210cm



17.011
ΚΟΥΠΙ SUP ΚΑΙ CANOE ΚΑΥΑΚ



95.034
ΣΧΑΡΕΣ ΑΥΤΟΚΙΝΗΤΟΥ ΜΑΛΑΚΕΣ ΜΙΚΡΕΣ



95.035
ΣΧΑΡΕΣ ΑΥΤΟΚΙΝΗΤΟΥ ΜΑΛΑΚΕΣ ΜΕΓΑΛΕΣ



95.044
ΒΑΣΗ ΣΤΗΡΙΞΗΣ SUP Κ ΚΑΝΟ ΓΙΑ ΡΕΛΙΑ ΣΚΑΦΟΥΣ

NEW



ΚΑΓΙΑΚ ΜΟΝΟ

ΚΩΔΙΚΟΣ	ΜΗΚΟΣ cm	ΠΛΑΤΟΣ cm	ΥΨΟΣ cm	ΒΑΡΟΣ kg	ΒΑΡΟΣ ΦΟΡΤΩΣΗΣ	ΧΡΩΜΑ
95.025A	266	66	25	18	125	ΚΟΚΚΙΝΟ
95.025B	266	66	25	18	125	ΚΙΤΡΙΝΟ
95.025C	266	66	25	18	125	ΜΠΛΕ
95.025D	266	66	25	18	125	ΘΑΛΑΣΣΙ
95.025E	266	66	25	18	125	ΠΡΑΣΙΝΟ

NEW

NEW



ΚΑΓΙΑΚ ΔΙΠΛΟ(1 ΕΝΗΛΙΚΑΣ + 1 ΠΑΙΔΙ)

ΚΩΔΙΚΟΣ	ΜΗΚΟΣ cm	ΠΛΑΤΟΣ cm	ΥΨΟΣ cm	ΒΑΡΟΣ kg	ΒΑΡΟΣ ΦΟΡΤΩΣΗΣ	ΧΡΩΜΑ
95.026A	238.5	78.3	29	16,6	125	ΚΟΚΚΙΝΟ
95.026B	238.5	78.3	29	16,6	125	ΚΙΤΡΙΝΟ
95.026C	238.5	78.3	29	16,6	125	ΜΠΛΕ



95.030

ΚΑΘΙΣΜΑ ΚΑΓΙΑΚ ΜΕΓΑΛΟ



95.029

ΚΑΘΙΣΜΑ ΠΛΑΤΗΣ ΚΑΓΙΑΚ ΜΙΚΡΟ



95.045

ΒΑΣΗ ΓΙΑ ΚΑΓΙΑΚ



ΚΑΓΙΑΚ ΔΥΟ ΕΝΗΛΙΚΕΣ +2 ΠΑΙΔΙΑ

ΚΩΔΙΚΟΣ	ΜΗΚΟΣ cm	ΠΛΑΤΟΣ cm	ΥΨΟΣ cm	ΒΑΡΟΣ kg	ΒΑΡΟΣ ΦΟΡΤΩΣΗΣ	ΧΡΩΜΑ
95.027A	340,5	84	29	24,6	220	ΚΟΚΚΙΝΟ
95.027B	340,5	84	29	24,6	220	ΚΙΤΡΙΝΟ
95.027C	340,5	84	29	24,6	220	ΜΠΛΕ



95.041

ΚΑΓΙΑΚ ΦΟΥΣΚΩΤΟ ΜΟΝΟ 275cm



95.042

ΚΑΓΙΑΚ ΦΟΥΣΚΩΤΟ ΔΙΠΛΟ 347cm



24.101-XX
ΝΙΤΣΕΡΑΔΑ ΕΝΙΣΧΥΜΕΝΗ
ΣΑΚΑΚΙ - ΠΑΝΤΕΛΟΝΙ ΣΕΤ
(S-XXL)



24.104-XXX
ΝΙΤΣΕΡΑΔΑ ΠΑΝΤΕΛΟΝΙ ΜΕ
ΜΠΟΤΕΣ ΕΝΣΩΜΑΤΩΜΕΝΕΣ
(39 - 46)



ΝΙΤΣΕΡΑΔΑ BUDGET (S-XXL)
ΕΝΙΣΧΥΜΕΝΗ / ΛΑΔΙ

24.105-XXX ΣΑΚΑΚΙ
24.108-XXX ΠΑΝΤΕΛΟΝΙ



ΝΙΤΣΕΡΑΔΑ POPULAR (S-XXL)

24.102-XXX ΣΑΚΑΚΙ ΛΑΔΙ
24.106-XXX ΣΑΚΑΚΙ ΠΟΡΤΟΚΑΛΙ
24.103-XXX ΠΑΝΤΕΛΟΝΙ ΛΑΔΙ
24.107-XXX ΠΑΝΤΕΛΟΝΙ ΠΟΡΤΟΚΑΛΙ



99.941B-XXX
ΠΑΝΤΕΛΟΝΙ ΙΣΤΙΟΠΛΟΙΑΣ
(S-XXL)



99.942B-XXX
ΜΠΟΥΦΑΝ ΙΣΤΙΟΠΛΟΙΑΣ
ΜΠΛΕ (S-XXL)



99.941A
ΠΑΝΤΕΛΟΝΙ ΙΣΤΙΟΠΛΟΙΑΣ
ΚΟΚΚΙΝΟ
(S-XXL)



99.942A
ΜΠΟΥΦΑΝ ΙΣΤΙΟΠΛΟΙΑΣ
ΚΟΚΚΙΝΟ
(S-XXL)

- WP 10.000mm
- MVP 15,000g/m²
- ΥΛΙΚΟ: ΡΤΦΕ 3 ΣΤΡΩΣΕΩΝ ΣΧΕΔΙΑΣΜΕΝΟ ΓΙΑ ΔΙΑΦΟΡΕΣ ΣΥΝΘΗΚΕΣ ΠΛΕΥΣΗΣ
- ΠΛΗΡΩΣ ΚΟΛΛΗΜΕΝΕΣ ΡΑΦΕΣ
- ΠΟΛΛΑΠΛΕΣ ΤΣΕΠΕΣ: 2 ΤΣΕΠΕΣ ΣΤΟ ΣΤΗΘΟΣ ΜΕ ΦΕΡΜΟΥΑΡ
4 ΚΑΤΩ ΤΣΕΠΕΣ ΓΙΑ ΘΕΡΜΑΝΤΗΡΑ ΧΕΡΙΩΝ
2 ΤΣΕΠΕΣ ΜΕ ΦΕΡΜΟΥΑΡ ΣΤΑ ΜΑΝΙΚΙΑ ΚΑΙ 1 ΕΣΩΤΕΡΙΚΗ ΤΣΕΠΗ ΜΕ ΦΕΡΜΟΥΑΡ



99.956X
ΜΠΛΟΥΖΑ SPEED QUICKDRY
ΙΣΤΙΟΠΛΟΙΑΣ (S-XXL)
A WHITE
B NAVY BLUE
C GRAY



99.978
ΚΑΠΕΛΟ ΜΕ ΣΧΟΙΝΙ
ΣΥΓΚΡΑΤΗΣΗΣ



99.988
ΒΕΡΜΟΥΔΑ ΣΚΑΦΟΥΣ
(S,M,L,XL)



99.975
ΓΥΑΛΙ ΗΛΙΟΥ POLARISED



99.945-XXX
ΓΑΝΤΙΑ ΙΣΤΙΟΠΛΟΙΑΣ ΜΑΚΡΙΑ
(XS-XXL)



99.980A
ΤΣΑΝΤΑ ΧΕΙΡΟΣ 50LT WATERPROOF



99.980B
ΤΣΑΝΤΑ ΧΕΙΡΟΣ 50LT WATERPROOF



ΤΣΑΝΤΑ ΑΔΙΑΒΡΟΧΗ
21.208 5Lt 40x15cm
21.206 12Lt 50x20cm
21.209 20Lt 50x25cm



99.981
ΤΣΑΝΤΑ CLASSIC
L77X W35 X H34 cm 90lt



99.984 -XX
ΠΑΠΟΥΤΣΙΑ ΔΕΡΜΑΤΙΝΑ
ΜΠΛΕ NAVY



99.983-XX
ΠΑΠΟΥΤΣΙΑ ΚΑΤΑΣΤΡΩΜΑΤΟΣ
ΔΕΡΜΑΤΙΝΑ ΚΑΦΕ
ΜΕ ΑΣΠΡΗ ΣΟΛΑ (37-46)



24.202-XX
ΜΠΟΤΑ ΙΣΤΙΟΠΛΟΙΑΣ ΜΠΛΕ
(37-46)



22.101
ΠΕΔΙΛΟ ΣΚΙ ΕΝΗΛΙΚΩΝ
COMBO 170cm



22.102
ΠΕΔΙΛΟ ΣΚΙ ΠΑΙΔΙΚΟ
155cm



22.103
ΠΕΔΙΛΟ ΣΚΙ ΠΑΙΔΙΚΟ
TRAINER 122cm



11.350
ΣΧΟΙΝΙ ΣΚΙ ΜΕ ΛΑΒΗ 25mt



11.360
ΣΧΟΙΝΙ ΣΚΙ ΤΡΙΓΩΝΟ ΜΕ ΡΑΟΥΛΟ



99.604
ΣΧΟΙΝΙ ΣΚΙ ΕΝΙΣΧΥΜΕΝΟ
ΜΕ ΛΑΒΗ / 25mt (ΣΕ BLISTER)



11.351
ΚΑΘΡΕΠΤΗΣ ΣΚΑΦΟΥΣ
ΓΙΑ ΣΚΙ



ΣΗΜΑΔΟΥΡΑ ΑΓΩΝΩΝ
ΚΟΚΚΙΝΗ

24.003 100x50cm
24.002 120x80cm
24.001 150x90cm



ΣΗΜΑΔΟΥΡΑ ΑΓΩΝΩΝ
ΚΙΤΡΙΝΗ

24.004 100x50cm
24.005 120x80cm
24.006 150x90cm



ΣΗΜΑΔΟΥΡΑ ΜΠΑΛΟΝΙ
ΜΕ ΤΡΥΠΑ 5cm

24.008 Ø43cm
24.009 Ø52cm



22.124

ΠΙΝΓΚΟΣ DELTA TUBE SLINGSHOT 150 cm



22.125

ΠΙΝΓΚΟΣ DELTA ΔΙΠΛΟ
RACE & RALLY 170 X 130 cm



22.121

ΠΙΝΓΚΟΣ ΣΤΡΟΓΓΥΛΟ ROCKET 140cm



22.127

ΠΙΝΓΚΟΣ HIGH VOLTAGE 200X200cm



22.129

ΠΙΝΓΚΟ HELL BENT 173 cm



99.600

ΜΠΑΝΑΝΑ 3 ΑΤΟΜΩΝ



99.601

ΜΠΑΛΟΝΙ OPTIMIST



26.001
ΜΠΡΕΛΟΚ ΣΩΣΙΒΙΟ
ΚΛΕΙΔΙΩΝ
(ΔΙΑΦΟΡΑ ΧΡΩΜΑΤΑ)



26.003
ΜΠΡΕΛΟΚ ΜΠΡΟΥΤΖΙΝΟ
ΑΓΚΥΡΑ ΚΑΒΟΥΡΙ



26.004
ΜΠΡΕΛΟΚ ΜΠΡΟΥΤΖΙΝΟ
ΜΑΚΑΡΑΔΑΚΙ



26.005
ΜΠΡΕΛΟΚ ΜΠΡΟΥΤΖΙΝΟ
ΜΑΚΑΡΑΔΑΚΙ ΞΥΛΙΝΟ



26.006
ΜΠΡΕΛΟΚ ΜΠΡΟΥΤΖΙΝΟ
ΠΛΕΥΡΙΚΟΣ ΦΑΝΟΣ
(ΚΟΚΚΙΝΟΣ-ΠΡΑΣΙΝΟΣ)



26.007
ΜΠΡΕΛΟΚ ΜΠΡΟΥΤΖΙΝΟ
ΠΡΟΠΕΛΑ



26.008
ΜΠΡΕΛΟΚ ΜΠΡΟΥΤΖΙΝΟ
ΣΚΑΦΑΝΔΡΟ



26.009
ΜΠΡΕΛΟΚ ΜΠΡΟΥΤΖΙΝΟ
ΣΦΥΡΙΧΤΡΑ



26.010
ΜΠΡΕΛΟΚ ΜΠΡΟΥΤΖΙΝΟ
ΤΙΜΟΝΙ



26.002
ΜΠΡΕΛΟΚ ΚΛΕΙΔΙΩΝ
ΜΠΑΛΟΝΙ



ΤΑΣΑΚΙ ΙΝΟΧ
ΑΝΤΙΑΝΕΜΙΚΟ
90.003 ΜΠΛΕ
90.004 ΚΟΚΚΙΝΟ



ΤΙΜΟΝΙ ΡΟΛΟΪ
97.115 ΜΕΓΑΛΟ
97.116 ΜΙΚΡΟ



**ΑΝΟΔΙΟ ΑΞΟΝΑ RADICE
ΑΠΟ 25 ΕΩΣ 50mm**

ΚΩΔ.	ΔΙΑΜ. mm
50.702	25
50.705	30
50.708	35
50.711	40
50.714	45
50.717	50



**ΑΝΟΔΙΟ ΑΞΟΝΑ RADICE
ΕΞΑΓΩΝΟ**

ΚΩΔ.	ΔΙΑΜ. mm
50.730	25
50.731	30
50.732	35
50.733	40
50.734	45
50.735	50



**ΑΝΟΔΙΑ ΑΞΟΝΑ
(ΑΒΓΟ)**

ΚΩΔ.	ΔΙΑΜ. mm
50.751	18
50.752	20
50.753	22
50.754	25
50.758	30
50.761	35
50.763	40
50.765	45
50.766	50



**ΑΝΟΔΙΟ ΑΞΟΝΑ
ΣΧΗΜΑ ΚΟΛΛΑΡΟΥ**

ΚΩΔ.	ΔΙΑΜ. mm
50.801	18
50.802	20
50.803	22
50.804	25
50.806	30
50.808	35
50.810	40
50.811	45
50.813	50



**ΑΝΟΔΙΟ ΓΙΑ ΦΛΑΠΣ
ΚΑΙ ΤΙΜΟΝΙΑ**

ΚΩΔ.	ΔΙΑΜ. mm
50.823	50
50.824	70
50.825	90
50.826	110
50.827	125



ΑΝΟΔΙΟ ΡΟΔΕΛΑ

ΚΩΔ.	ΔΙΑΜ. mm
50.703	25
50.706	30
50.709	35



**80.910
ΑΝΟΔΙΟ ΓΙΑ ΦΛΑΠΣ
& ΠΗΔΑΛΙΑ 1KG**



**80.920
ΑΝΟΔΙΟ ΓΙΑ ΦΛΑΠΣ
& ΠΗΔΑΛΙΑ 2.4KG**

**80.935
ΑΝΟΔΙΟ ΓΙΑ ΦΛΑΠΣ
& ΠΗΔΑΛΙΑ 2,5KG**



**80.936
ΑΝΟΔΙΟ ΓΙΑ ΦΛΑΠΣ
& ΠΗΔΑΛΙΑ 0.3KG**



**50.701
ΑΝΟΔΙΟ VETUS OG028 F-BC-3
L40 x W24 x H24mm**



**50.901
ΑΝΟΔΙΟ SLEIPNER
L42 x H36mm ΕΞΑΓΩΝΟ
Φ25mm**



**50.902
ΑΝΟΔΙΟ SLEIPNER
ΕΞΑΓΩΝΟ
Φ19mm L44 x H20mm**



**ΑΝΟΔΙΟ BOWTHRUSTER
ΕΞΑΓΩΝΟ
50.992 Φ17mm
50.993 Φ19mm**



**50.903
ΑΝΟΔΙΟ FLEX FOLD L68 x H37mm**



**50.905
ΑΝΟΔΙΟ VETUS 1kg**



**50.937
ΑΝΟΔΙΟ 1,5kg
L145 x W67mm**



50.000

**ANODO BOMBARDIER
2-150HP 173029**



50.001

**ANODO BOMBARDIER
50-75HP 392462
L100 x W63 x H35mm**



50.002

**ANODO BOMBARDIER
50÷200HP 436745
L40 x W38 Ø9mm**



30

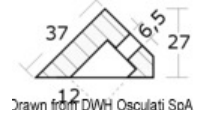

Drawn from DWH Osculati SpA

50.003

**ANODO BOMBARDIER
334451 HP4-7.5**

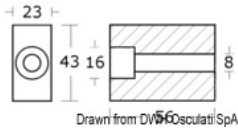

Drawn from DWH Osculati SpA

50.004

**ANODO BOMBARDIER
60÷175HP 398331**



50.005

**ANODO BOMBARDIER
HP 40-50 398873**

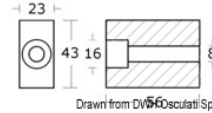

Drawn from DWH Osculati SpA

50.006

**ANODO BOMBARDIER
HP 60-280 433458**

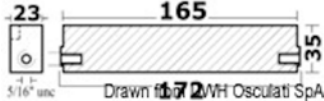

Drawn from DWH Osculati SpA

50.007

**ANODO BOMBARDIER
60÷250HP 433580**



50.008

**ANODO BOMBARDIER
60÷250HP 5007089
NEO MONTEAO**

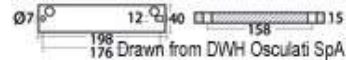

Drawn from DWH Osculati SpA

50.009

**ANODO BOMBARDIER
(EVINRUDE)70HP
4STR 5034616**

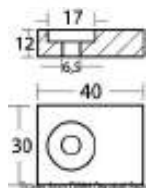

50.010

**ANODO BOMBARDIER
40-50HP 4STR 5030265**

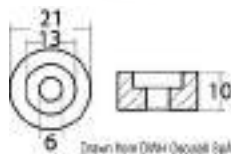

Drawn from DWH Osculati SpA

50.011

**ANODO BOMBARDIER 3,5HP
& 5-6HP 4STR 5031705**

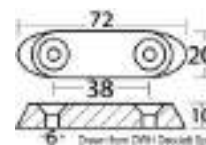

Drawn from DWH Osculati SpA

50.012

**ANODO BOMBARDIER
70÷90HP 5031538**



50.051
ANODIO HONDA
8-15-20HP 411062W-9000



50.052
ANODIO HONDA
8HP 4106-ZW-000



50.053
ANODIO HONDA
06411-ZV-5000 HP 40-50



50.054
ANODIO HONDA
75÷130HP 06411-ZW1-000

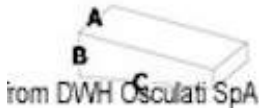

50.055
ANODIO HONDA
75÷130HP 4110-ZW-1003
A29 x B22 x C77mm

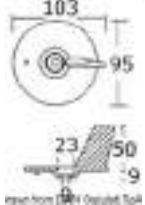

50.056
ANODIO HONDA
25-40-50HP 41107-ZV-5000

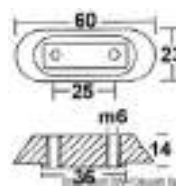

50.057
ANODIO HONDA
10-50HP 41106-935-812



50.058
ANODIO HONDA
8-10-15HP 41106-ZW9-000



50.059
ANODIO HONDA
75÷130-225HP
41109-2WT-BB00
L71 X W36 X H17mm

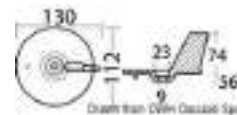

50.060
ANODIO HONDA
75-90-115-130 HP
41107-ZW1-B01ZA

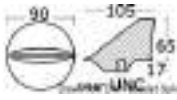

50.101

**ΑΝΟΔΙΟ MERCURY
40HP EFI-50-75 4STR 31640Q4**

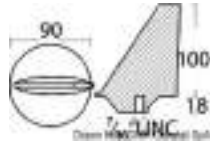

50.102

**ΑΝΟΔΙΟ MERCURY
80-140HP 34127A1**

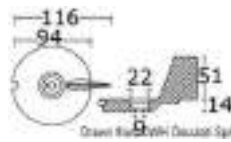

50.104

**ΑΝΟΔΙΟ MERCURY
20-25HP 94286T1**



50.105

**ΑΝΟΔΙΟ MERCURY
15-25HP 4STR 9843296**



50.106

**ΑΝΟΔΙΟ MERCURY
4HP 8239139**

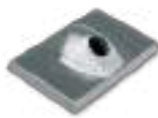

50.108

**ΑΝΟΔΙΟ MERCURY
6-9,9-15HP 4STR 4212A2**



50.110

**ΑΝΟΔΙΟ MERCURY-
MERCUISER BRAVO I
55989Q9 A33 x B29mm**



50.111

**ΑΝΟΔΙΟ MERCURY 40÷75HP
- 40÷250HP 818298Q1**



50.112

**ΑΝΟΔΙΟ MERCURY -
MERCUISER HP50-75
43396
L190 x W52 x H20mm**



50.113

**ΑΝΟΔΙΟ ALPHA I
821629Q1**

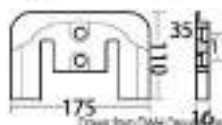

50.114

**ΑΝΟΔΙΟ MERCUISER
MERCURY BRAVO 8216630Q1**



50.116

**ΑΝΟΔΙΟ MERCUISER-
MERCURY ALPHA II 43994A2**



50.117

**ΑΝΟΔΙΟ MERCURY-
MERCUISER 0.120 Kgr
ALPHA I 8061189Q1**



50.118

**ΑΝΟΔΙΟ MERCURY 75-
250-75HP
Ω4STR 826134**

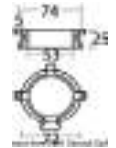

50.119

ΑΝΟΔΙΟ ALPHA I

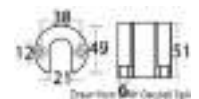

50.121

**ΑΝΟΔΙΟ MERCURY-
MERCUISER ΓΙΑ ΠΙΣΤΟΝΙ
ΑΝΟΔΙΟ BRAVO III 8061190Q1**



50.122

**ANODO MERCURY
-MERCUISER ALPHA**
150-250HP 76214-5

50.135

**ANODO MERCURY-
MERCUISER BRAVO 2**
76214-4



50.123

ANODO MERCURY
25-30-40HP 4STR 822157T2



50.125

ANODO MERCURY
25-30-40HP 4S 825271-1



50.130

ANODO MERCURY
40HP 822912002



50.134

ANODO BRAVO III
865182Q01



50.139

**ANODO
MERCURY-MERCUISER**
826887M

SELVA



50.152

ANODO SELVA 9005655
L62 x W15 x H4mm



50.156

ANODO SELVA
HP25-40 2500065
L40 x H 49mm



50.157

ANODO SELVA
8-15HP 2504020

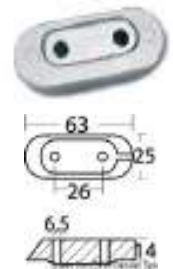

50.159

ANODO SELVA 40HP



50.301

VOLVO PENTA 875810
A98 x B52 x C70 x D11mm

50.302

VOLVO PENTA 875809
A107 x B58 x C80 x D11mm

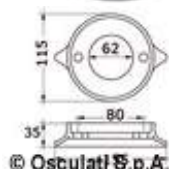

50.304

VOLVO PENTA 875815

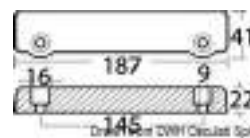

50.307

VOLVO PENTA 250-270-280



50.308

VOLVO PENTA 852835

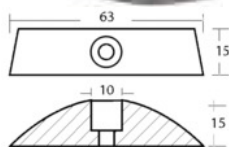

50.309

VOLVO PENTA 852018

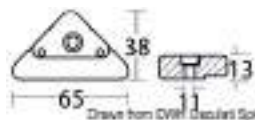

50.312

VOLVO 872793

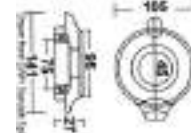

50.326

VOLVO PENTA SAIL
DRIVE 3888305

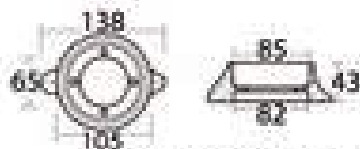

© Osculati S.p.A.

50.327

ANODIO VOLVO VP005
875812 SAIL DRIVE 110



© Osculati S.p.A.

50.329

ANODIO VOLVO VP011 SEA
DRIVE 876286



© Osculati S.p.A.

50.328

ANODIO VOLVO VP006 DUE PROP 875821
A110 X B34 X C145 X D91 X E85mm



50.330

ANODIO VOLVO VP006B DUE PROP
A110 X B30 X C145 X D91 X E85mm



50.204
ΑΝΟΔΙΟ SUZUKI
 30-94600A 4-6 HP 140-250HP



50.209
ΑΝΟΔΙΟ SUZUKI
 55321-93900 9.9-15 HP



50.210
ΑΝΟΔΙΟ SUZUKI
 55320-94900
 HP70-90-115-140



50.212
ΑΝΟΔΙΟ SUZUKI
 55320-98400 9.9-15 HP
 4 XPONH



50.213
ΑΝΟΔΙΟ SUZUKI
 90-115HP DF 115-140
 55321-90J01



50.211
ΑΝΟΔΙΟ SUZUKI SU003
 HP40-115

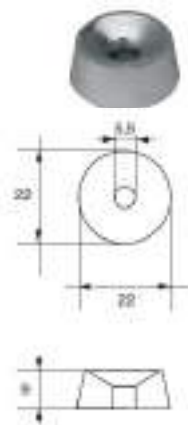

50.205
ΑΝΟΔΙΟ SUZUKI

TOHATSU, YANMAR



50.251
ΑΝΟΔΙΟ TOHATSU
 369-60218-1 HP 2.5-8



50.254
ΑΝΟΔΙΟ TOHATSU
 25-50HP
 MEGA33C8-60217-0



50.257
ΑΝΟΔΙΟ TOHATSU
 40÷140HP
 MEGA3C7-60218-1



50.507
ΑΝΟΔΙΟ YANMAR
 19644002660 ΓΙΑ ΜΗΧΑΝΕΣ
 SD20-SD30-SD31-
 SD40-SD50



50.508
ΑΝΟΔΙΟ YANMAR
 196 420 0026 52

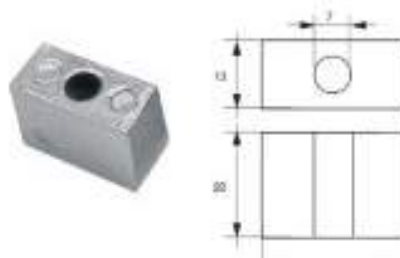

50.255
ΑΝΟΔΙΟ
TOHATSU-NISSAN



50.433

ΑΝΟΔΙΟ YAMAHA-MARINER
65W-45251-00 25HP 4 STR



50.407

ΑΝΟΔΙΟ YAMAHA
60-90HP 6H4-45251-01



50.410

ΑΝΟΔΙΟ YAMAHA-MARINER
ΜΠΑΡΑ 6G5-45251-02 HP
115-225



50.420

ΑΝΟΔΙΟ YAMAHA-MARINER
9.9-15HP 6E8-45251



50.424

ΑΝΟΔΙΟ YAMAHA
ΚΥΒΟΣ HP75 XR6 866C34Q
L77 x W9mm



50.436

ΑΝΟΔΙΟ YAMAHA-MARINER
62Y-11325-00 HP 40-50
L50 x W17mm



50.444

ΑΝΟΔΙΟ YAMAHA-MARINER
20-25HP 6J8-11325-00



50.454

ΑΝΟΔΙΟ YAMAHA-MARINER
676-45251-00 40Q-40X

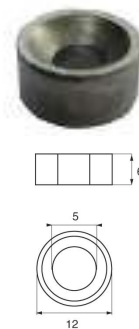

50.457

ΑΝΟΔΙΟ YAMAHA-MARINER
63P-11325-11



50.408

ΑΝΟΔΙΟ YAMAHA
2-25HPQ
L25 x H9 x 5.5mm



50.409

ΑΝΟΔΙΟ YAMAHA
40-85HPQ
L51 x H14 x 8.5mm



50.606

ΑΝΟΔΙΟ ΓΙΑ ΜΗΧΑΝΗ G.M.
8517480 ΠΛΑΤΟΣ 16 ΜΗΚΟΣ
54 ΣΠΕΙΡΩΜΑ 7/16"



50.607

ΑΝΟΔΙΟ ΓΙΑ ΜΗΧΑΝΗ G.M. ΜΕ
ΤΑΠΑ ΠΛΑΤΟΣ 16 ΜΗΚΟΣ 54
ΣΠΕΙΡΩΜΑ 7/16" W ΤΑΠΑ 1/2"
NPT.PNG



50.622

ΑΝΟΔΙΟ ΓΙΑ ΜΗΧΑΝΗ
VOLVO PENTA ΠΛΑΤΟΣ
16 ΜΗΚΟΣ 40 ΣΠΕΙΡΩΜΑ
7/16" W



50.624

ΑΝΟΔΙΟ ΓΙΑ ΜΗΧΑΝΗ
VOLVO PENTA ΠΛΑΤΟΣ
16 ΜΗΚΟΣ 30 ΣΠΕΙΡΩΜΑ
7/16" W, 8ΜΑ



50.628

ΑΝΟΔΙΟ ΓΙΑ ΜΗΧΑΝΗ
VOLVO PENTA ΠΛΑΤΟΣ 25
ΜΗΚΟΣ 44 ΣΠΕΙΡΩΜΑ 3/8"
UNC" INSERT



50.650

ΑΝΟΔΙΟ ΓΙΑ CATERPILLAR
ΠΛΑΤΟΣ 10 ΜΗΚΟΣ 55
ΣΠΕΙΡΩΜΑ 1/4" 6L2283



50.658

ΑΝΟΔΙΟ ΓΙΑ
CATERPILLAR ΠΛΑΤΟΣ
12 ΜΗΚΟΣ 41 ΣΠΕΙΡΩΜΑ
3/8" W 6L2280P

KIT



50.141
KIT ΑΝΟΔΙΩΝ
VERADO 6



50.142
KIT ΑΝΟΔΙΩΝ
VERADO 4



50.143
KIT ΑΝΟΔΙΩΝ MERCURY-
MERCURISER
ALPHA I - ΓΕΝΙΑΣ I



50.145
KIT ΑΝΟΔΙΩΝ
BRAVO I 888758Q01



50.146
KIT ΑΝΟΔΙΩΝ MERCURY-MERCURISER
BRAVO II-III 888761Q01



50.144
KIT ΑΝΟΔΙΩΝ MERCURY-MERCURISER
ALPHA I - ΓΕΝΙΑΣ II
888756Q01

► Ακρυλικές βαφές Marine Motor Paint με οικολογικό προωθητικό

Οι βαφές μας SPRAY παράγονται σύμφωνα με τις προδιαγραφές που παρέχονται από το εργοστάσιο του κατασκευαστή. Επιπλέον, τα spray είναι εφοδιασμένα με μία βαλβίδα εκνέφωσης που αποτρέπει τα σταγονίδια του μη κοιοτροποιημένου βερνικιού που συχνά εμφανίζονται για μια ατελή δοσολογία του αερίου από τον χειριστή. Μπορούν επομένως να χρησιμοποιηθούν από αρχάριους με εξαιρετικό αποτέλεσμα.



Ακρυλικά χρώματα σε σπρέι για εσωλέμβιους κινητήρες AIFO/FPT

Κωδικός	Χρώμα	Έτος	Φιάλη ml	
87.024	<input checked="" type="checkbox"/> Κόκκινο	1984 και επόμενα	400	6
87.025	<input type="checkbox"/> Λευκό	Όλοι	400	6

Ακρυλικά χρώματα για κινητήρες MERCURY

Κωδικός	Χρώμα	Έτος	Φιάλη ml	
87.045	<input checked="" type="checkbox"/> Μαύρο	Όλα	400	6
87.046	- Zinc primer για πρώτο χέρι	Όλα	400	6

Ακρυλικά χρώματα σε σπρέι για κινητήρες CATERPILLAR

Κωδικός	Χρώμα	Έτος	Φιάλη ml	
87.047	<input checked="" type="checkbox"/> Κίτρινο	Όλα	400	6
87.048	<input type="checkbox"/> Λευκό	Όλα	400	6

Ακρυλικά χρώματα σε σπρέι για εξωλέμβιους κινητήρες EVINRUDE

Κωδικός	Χρώμα	Έτος	Φιάλη ml	
87.027	- Zinc primer (πρώτο χέρι)	Όλοι	400	6
87.028	<input type="checkbox"/> Λευκό	1977 και επόμενα	400	6
87.029	<input checked="" type="checkbox"/> Μπλε ανοικτό	1978/1987	400	6
87.030	<input type="checkbox"/> Λευκό	1981 και επόμενα	400	6
87.031	<input checked="" type="checkbox"/> Μπλε	1986 και επόμενα	400	6
87.032	<input checked="" type="checkbox"/> Ασημί	1987 και επόμενα	400	6

Ακρυλικά χρώματα σε σπρέι για εξωλέμβιους κινητήρες JOHNSON

Κωδικός	Χρώμα	Έτος	Φιάλη ml	
87.033	- Zinc primer (πρώτο χέρι)	Όλα	400	6
87.034	<input type="checkbox"/> Λευκό	1971/1980	400	6
87.035	<input type="checkbox"/> Λευκό	1981 και επόμενα	400	6
87.036	<input checked="" type="checkbox"/> Γκρι "GT"	1988 και επόμενα	400	6

Ακρυλικά χρώματα σε σπρέι για κινητήρες YAMAHA

Κωδικός	Χρώμα	Έτος	Φιάλη ml	
87.049	- Zinc primer (πρώτο χέρι)	Όλα	400	6
87.050	<input checked="" type="checkbox"/> Μπλε μεταλλικό	1974/1985	400	6
87.051	<input checked="" type="checkbox"/> Μπλε μεταλλικό	1984/1993	400	6
87.052	<input checked="" type="checkbox"/> Γκρι μεταλλικό	1994 και μετά	400	6
87.053	<input type="checkbox"/> Λευκό	από το 2010	400	6

Ακρυλικά χρώματα σε σπρέι για κινητήρες MARINER

Κωδικός	Χρώμα	Έτος	Φιάλη ml	
87.054	- Zinc primer (πρώτο χέρι)	Όλοι	400	6
87.055	<input checked="" type="checkbox"/> Γκρι	1977 και επόμενα	400	6
87.056	<input checked="" type="checkbox"/> Μαύρο	Όλα (τεμάχιο ποδιού)	400	6

Ακρυλικά χρώματα σε σπρέι για κινητήρες YANMAR

Κωδικός	Χρώμα	Έτος	Φιάλη ml	
87.037	<input checked="" type="checkbox"/> Γκρι μεταλλικό	Όλα	400	6

Ακρυλικά χρώματα σε σπρέι για κινητήρες NANNI

Κωδικός	Χρώμα	Έτος	Φιάλη ml	
87.057	<input checked="" type="checkbox"/> Μπλε μεταλλικό	Όλα	400	6

Ακρυλικά χρώματα σε σπρέι για OMC

Κωδικός	Χρώμα	Έτος	Φιάλη ml	
87.038	<input type="checkbox"/> Λευκό	Όλα	400	6

Ακρυλικά χρώματα σε σπρέι για κινητήρες HONDA				
Κωδικός	Χρώμα	Έτος	Φιάλη ml	
87.058	Γκρι χρυσό μεταλλικό	Όλα	400	6
87.062	Ασημί	Από το 2013	400	6

Ακρυλικά χρώματα σε σπρέι για κινητήρες SELVA				
Κωδικός	Χρώμα	Έτος	Φιάλη ml	
87.039	Γκρι	Από το 2010	400	6
87.040	Μπλε μεταλλικό (4 X)	Όλοι	400	6
87.041	Μπλε μεταλλικό (2 X)	Όλοι	400	6
87.042	Λευκό	Από το 2010	400	6

Ακρυλικά χρώματα σε σπρέι για κινητήρες TOHATSU				
Κωδικός	Χρώμα	Έτος	Φιάλη ml	
87.059	Γκρι μεταλλικό	Όλοι	400	6
87.060	Μπλε κοβαλτίου	Όλοι	400	6
87.061	Μπλε σκούρο (aquamarine blue)	Όλοι	400	6

Ακρυλικά χρώματα σε σπρέι για κινητήρες SUZUKI				
Κωδικός	Χρώμα	Έτος	Φιάλη ml	
87.043	Γκρι	1989 και μετά	400	6
87.022	Pearl nebular black	2017 και μετά	400	6
87.023	Λευκό cool white	2000 και μετά	400	6
87.044	- Διαφανές	Όλα	400	6
87.063	Γκρι σκούρο (4 T)	Όλα	400	6

Ακρυλικά χρώματα σε σπρέι για κινητήρες VOLVO Penta					
Κωδικός	Χρώμα	Έτος	OEM Ref	Φιάλη ml	
87.004	- Zinc primer (πρώτο χέρι)	Όλα	1141562	400	6
87.005	Πράσινο (εσωλήμβια)	1979 και επόμενα	1141566	400	6
87.006	Γκρι aquamatic	1989 και επόμενα	1141575	400	6
87.007	Κόκκινο	1970 και επόμενα	827501	400	6
87.008	Γκρι μεταλλικό	1995 και επόμενα	3851219	400	6
87.009	Ασημί DPH, DPR, SX-A	Όλα	889968	400	6
87.010	Ασημί DPX	Όλα	3851220	400	6
87.011	Μαύρο γυαλιστερό	Όλα	3851221	400	6
87.012	- Διαφανές γυαλιστερό	Όλα	827502	400	6

* IPS 1° σειρά A, B, C (μέχρι SN 3194009615)
 ** IPS 15, 2, 3, 30 και IPS "D" και επόμενα (από SN 3194009610)
 A+B: γνήσια VOLVO

Ακρυλικά χρώματα σε σπρέι για όλους τους κινητήρες VETUS				
Κωδικός	Χρώμα	Φιάλη ml		
87.021	Κίτρινο	400	6	

Ακρυλικά χρώματα σε σπρέι για διάφορους κινητήρες				
Κωδικός	Χρώμα	Φιάλη ml		
87.001	- Διαφανές γυαλιστερό	400	6	

Ακρυλικά χρώματα σε σπρέι για KHOLER - γεννήτριες				
Κωδικός	Χρώμα	Έτος	Φιάλη ml	
87.002	Λευκό	Όλα	400	6

Ακρυλικά χρώματα για όλους τους κινητήρες VM				
Κωδικός	Χρώμα	Έτος	Φιάλη ml	
87.015	Μπλε-Γκρι	Όλα	400	6

Ακρυλικά χρώματα για κινητήρες CUMMINS				
Κωδικός	Χρώμα	Έτος	Φιάλη ml	
87.014	Λευκό	Όλα	400	6

Antifouling Σπρέι για πόδια και προπέλες

Κωδικός	Χρώμα	Φιάλη ml
87.016	Λευκό	400
87.017	Μαύρο	400
87.018	Βορνο γκρι	400
87.019	Διάφανο	400
87.020	Αστάρι	400





ΝΙΚΟΛΑΪΔΗΣ Α.-ΝΙΚΟΛΑΪΔΗΣ Γ.Β. Ο.Ε.
ΕΜΠΟΡΙΑ & ΒΙΟΤΕΧΝΙΑ ΝΑΥΤΙΛΙΑΚΩΝ ΕΙΔΩΝ

Αθηνάς 16 - 182 33 Αγ. Ιωάννης Ρέντης
Τηλ. 210 4915208, 210 4906945 • Fax: 210 4910 809
e-mail: info@sailmarine.gr

www.sailmarine.gr